

BBM 202 - ALGORITHMS



HACETTEPE UNIVERSITY

DEPT. OF COMPUTER ENGINEERING

BINARY SEARCH TREES

Acknowledgement: The course slides are adapted from the slides prepared by R. Sedgewick and K. Wayne of Princeton University.

TODAY

- ▶ **BSTs**
- ▶ **Ordered operations**
- ▶ **Deletion**

Binary Search Tree (BST)

- Last lecture, we talked about binary search & linear search
 - One had high cost for reorganisation,
 - The other had high cost for searching
- In this lecture we will use Binary Trees, for searching
- Plan in a nutshell:
 - Assert a more strict property compared to the Heap-Property (in priority-queues), **Remember what that was?**
 - Know exactly which subtree to look for at each node

Binary search trees

Definition. A BST is a **binary tree** in **symmetric order**.

A binary tree is either:

- Empty.
- Two disjoint binary trees (left and right).

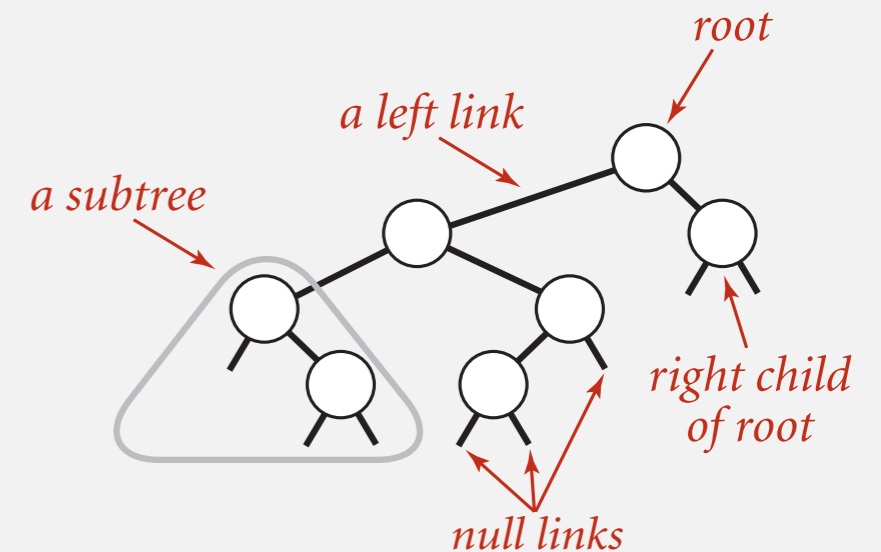

Anatomy of a binary tree

Symmetric order. Each node has a key, and every node's key is:

- Larger than all keys in its left subtree.
- Smaller than all keys in its right subtree.

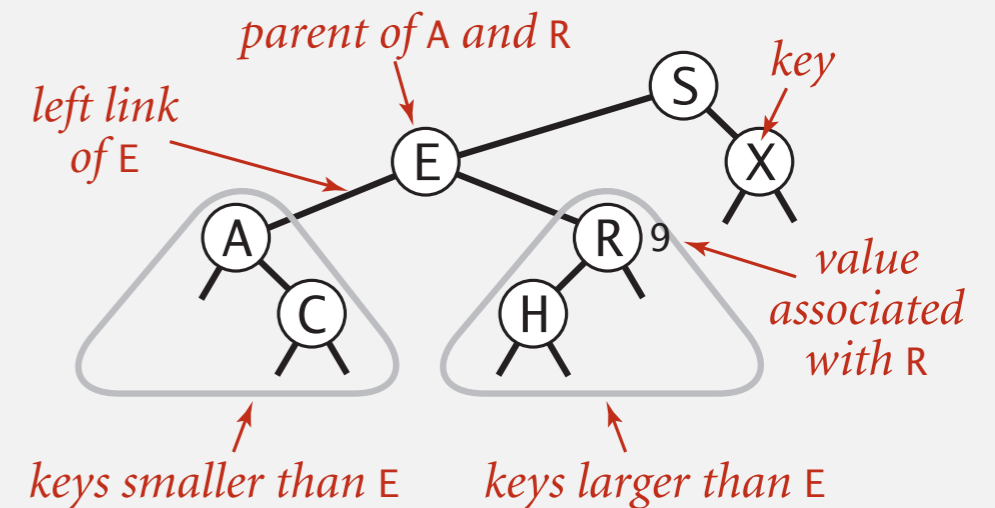

Anatomy of a binary search tree

BST representation in Java

Java definition. A BST is a reference to a root `Node`.

A `Node` is comprised of four fields:

- A `key` and a `value`.
- A reference to the left and right subtree.

↑ smaller keys ↑ larger keys

```
private class Node
{
    private Key key;
    private Value val;
    private Node left, right;
    public Node(Key key, Value val)
    {
        this.key = key;
        this.val = val;
    }
}
```

Key and Value are generic types; Key is Comparable

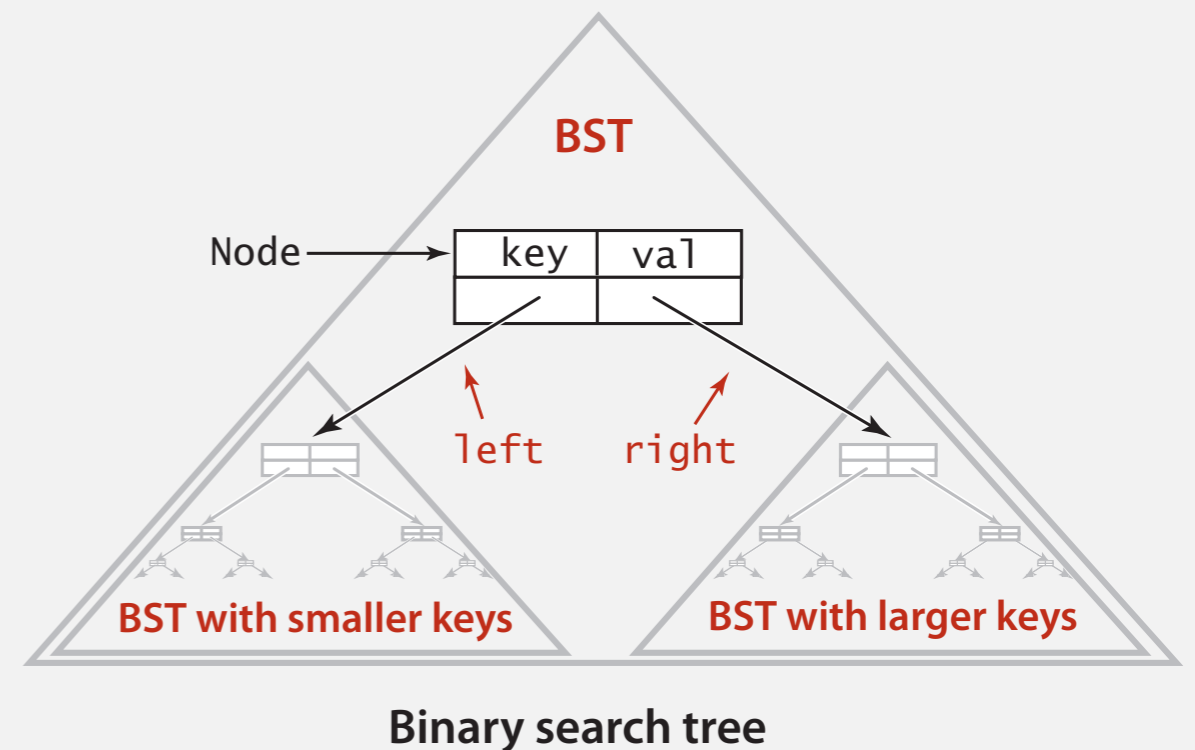

BST implementation (skeleton)

```
public class BST<Key extends Comparable<Key>, Value>
{
    private Node root;

    private class Node
    { /* see previous slide */ }

    public void put(Key key, Value val)
    { /* see next slides */ }

    public Value get(Key key)
    { /* see next slides */ }

    public void delete(Key key)
    { /* see next slides */ }

    public Iterable<Key> iterator()
    { /* see next slides */ }
}
```

← root of BST

Binary search tree operations

Search. If less, go left; if greater, go right; if equal, search hit.

successful search for H

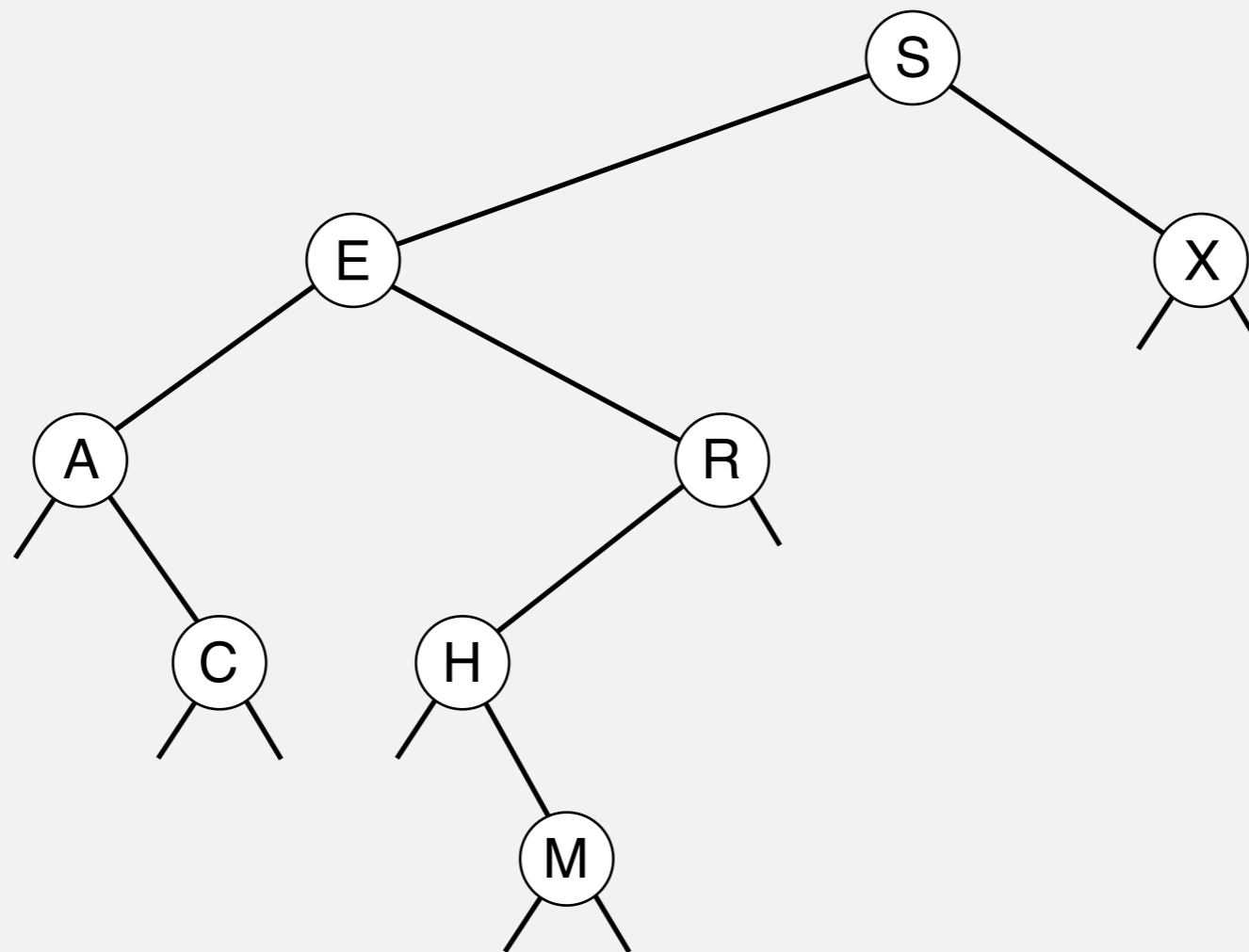

Binary search tree operations

Search. If less, go left; if greater, go right; if equal, search hit.

successful search for H

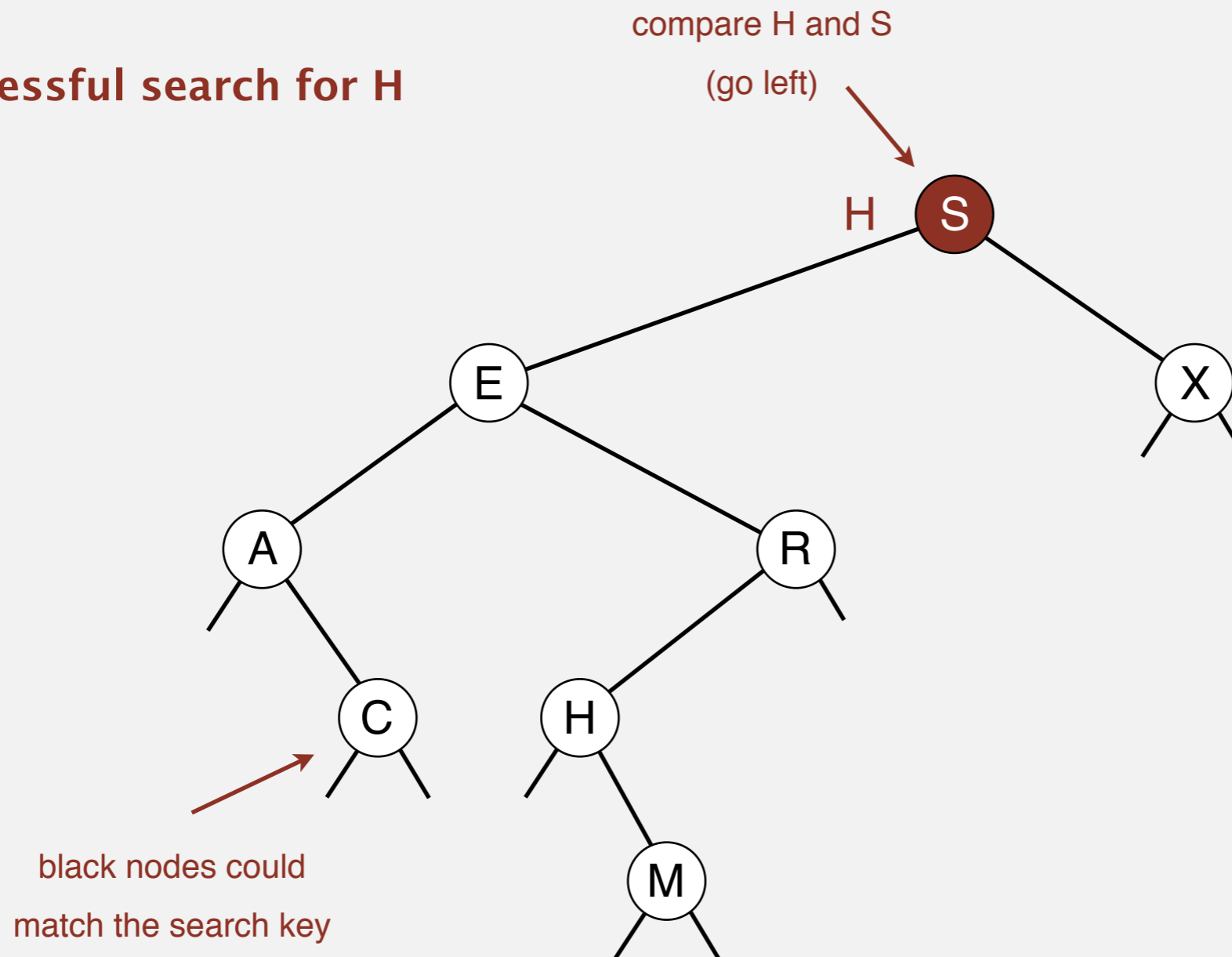

Binary search tree operations

Search. If less, go left; if greater, go right; if equal, search hit.

successful search for H

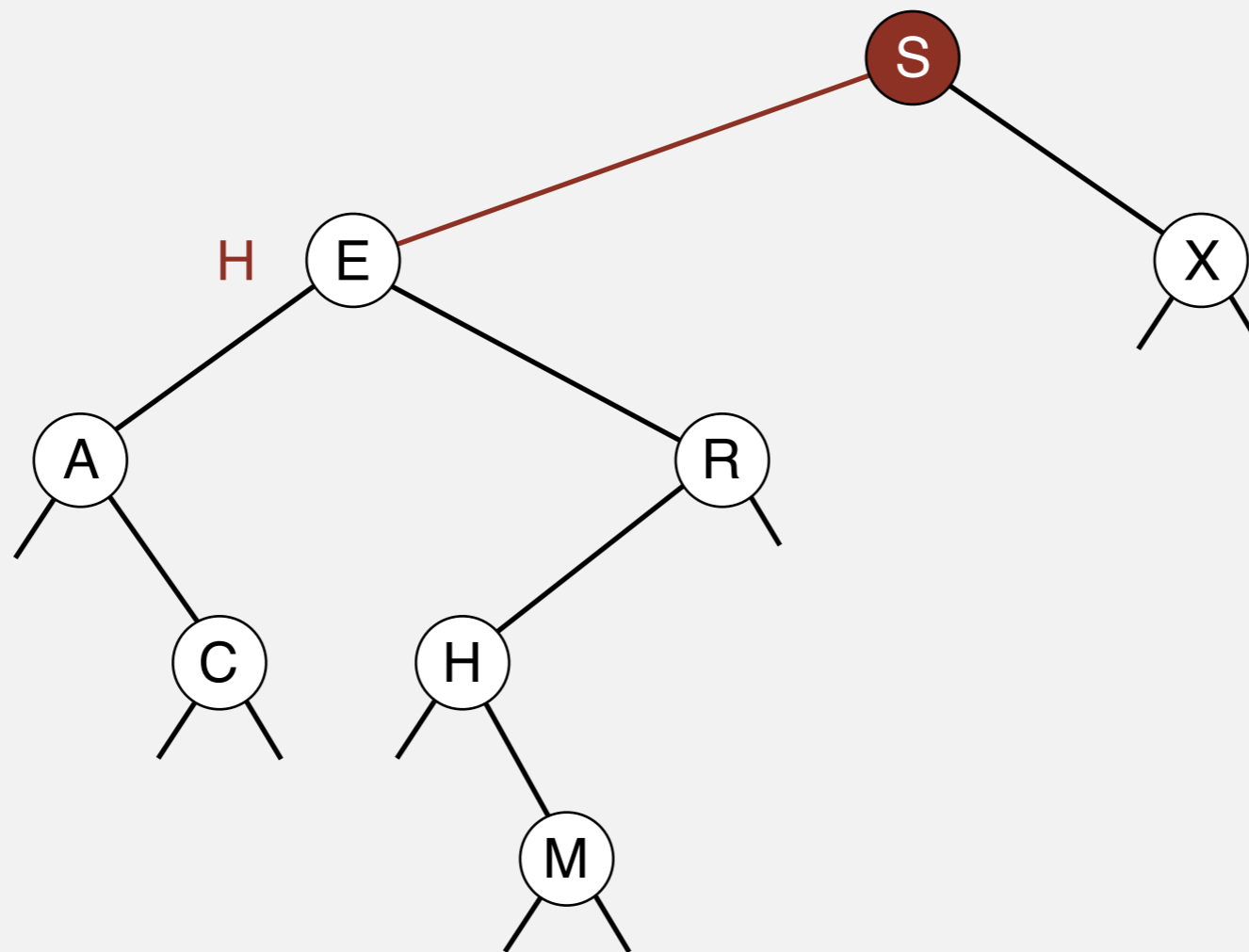

Binary search tree operations

Search. If less, go left; if greater, go right; if equal, search hit.

successful search for H

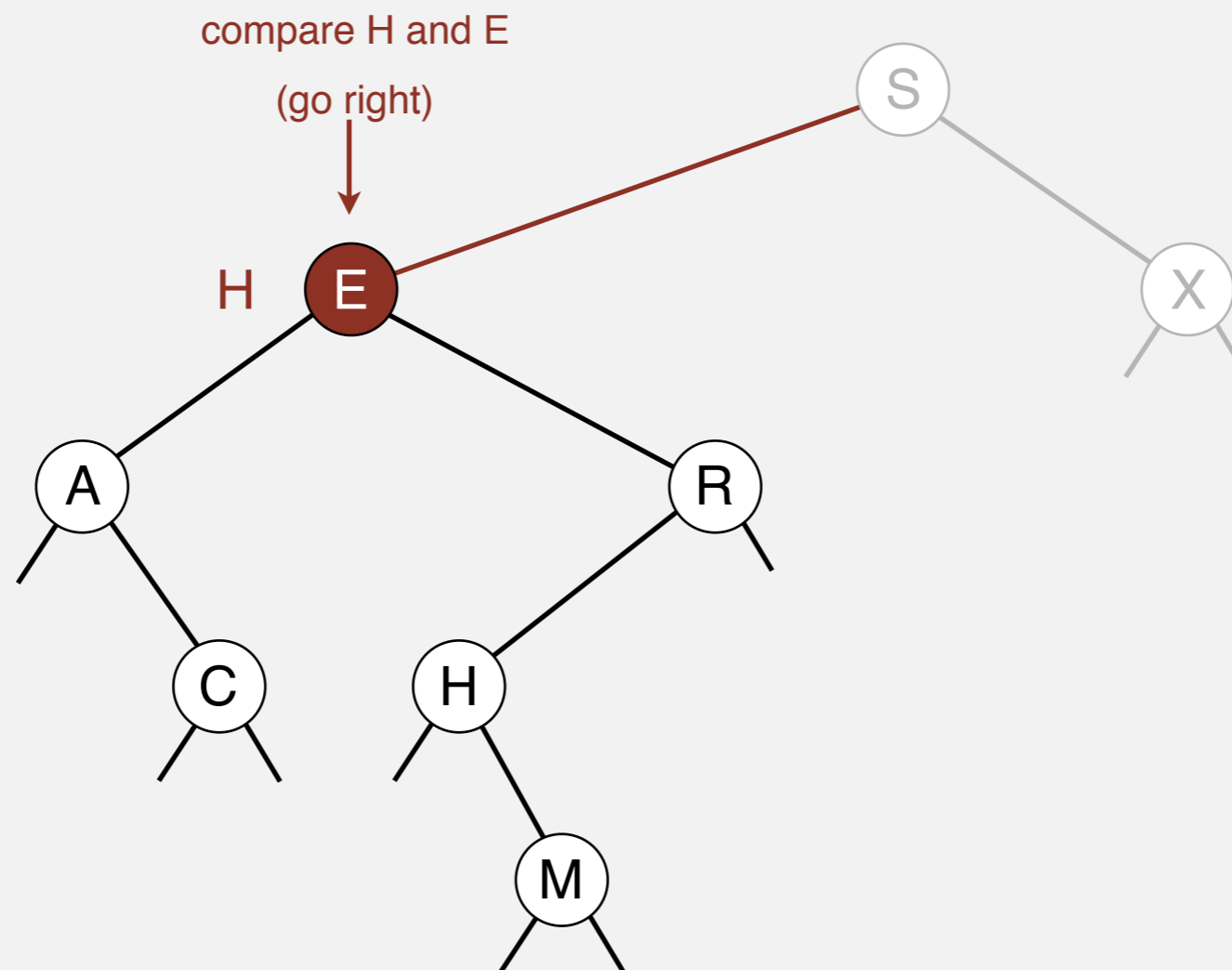

Binary search tree operations

Search. If less, go left; if greater, go right; if equal, search hit.

successful search for H

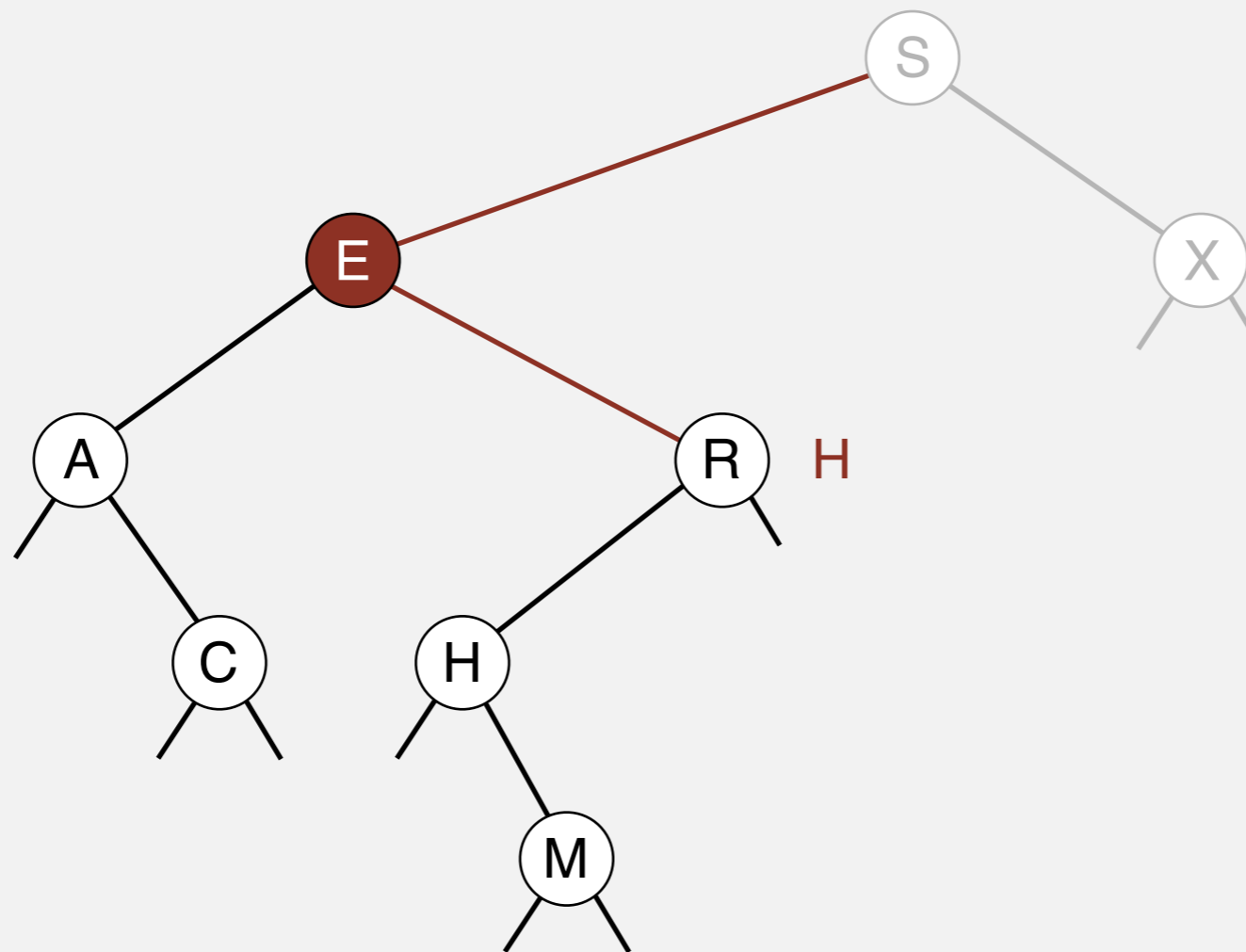

Binary search tree operations

Search. If less, go left; if greater, go right; if equal, search hit.

successful search for H

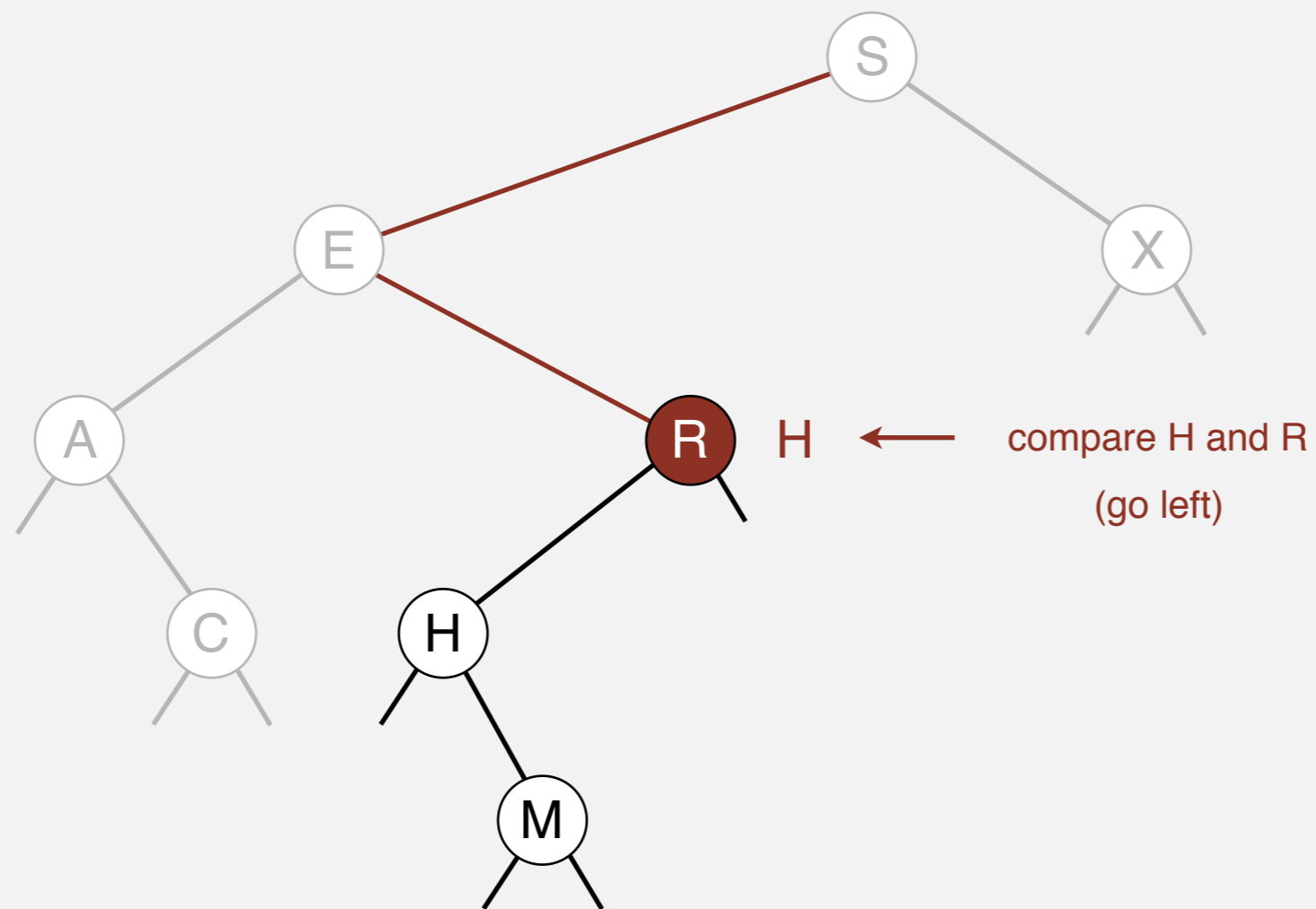

Binary search tree operations

Search. If less, go left; if greater, go right; if equal, search hit.

successful search for H

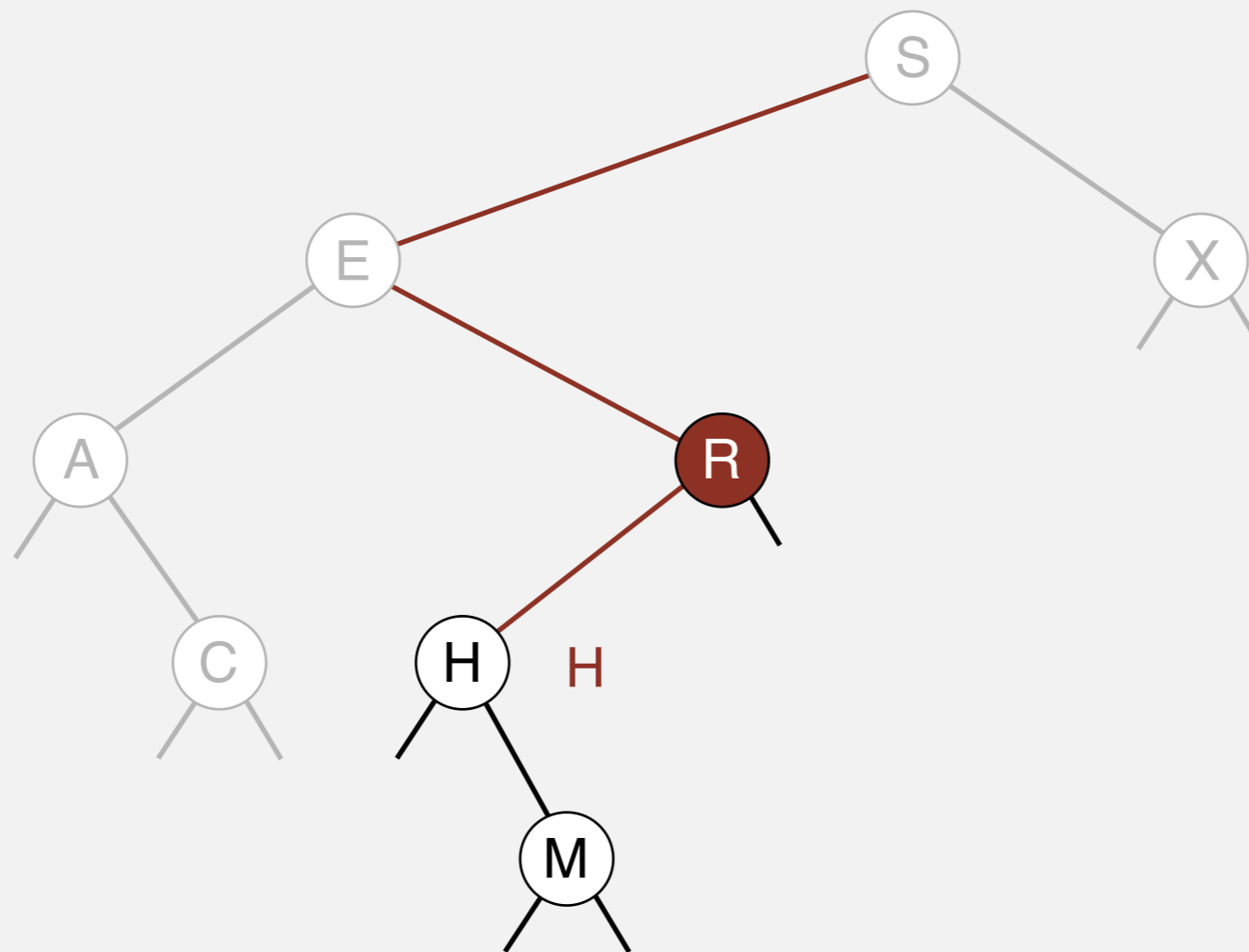

Binary search tree operations

Search. If less, go left; if greater, go right; if equal, search hit.

successful search for H

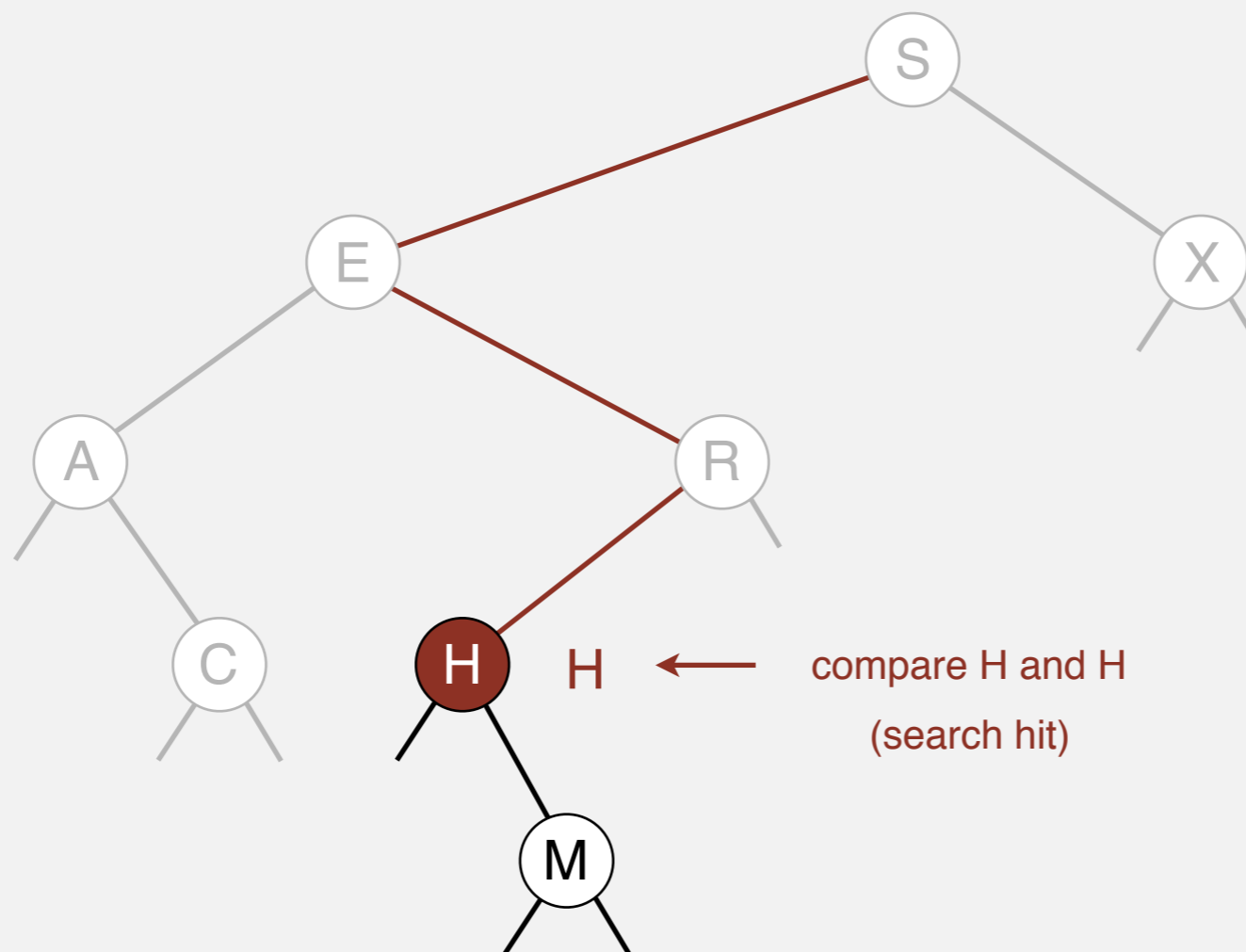

Binary search tree operations

Search. If less, go left; if greater, go right; if equal, search hit.

unsuccessful search for G

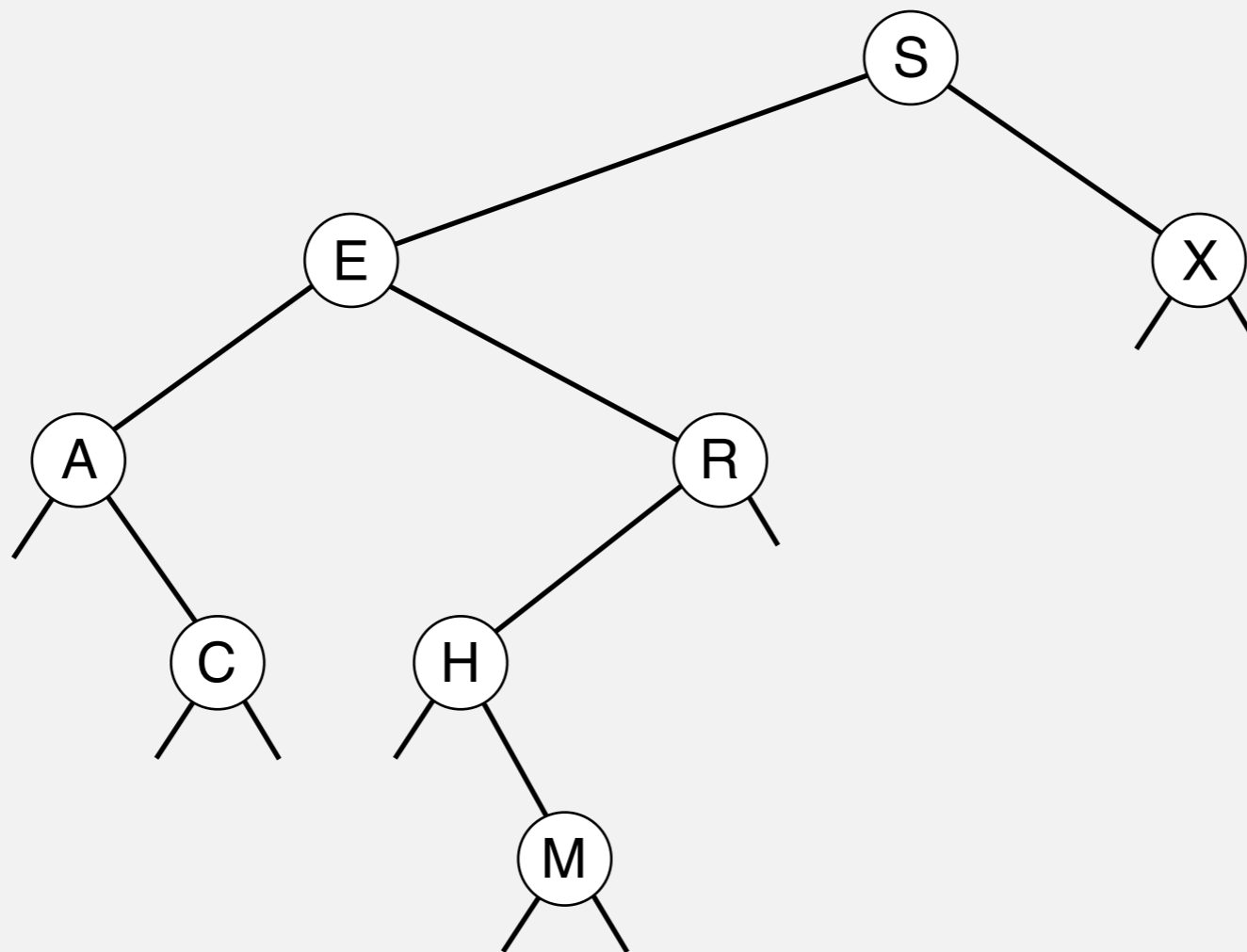

Binary search tree operations

Search. If less, go left; if greater, go right; if equal, search hit.

unsuccessful search for G

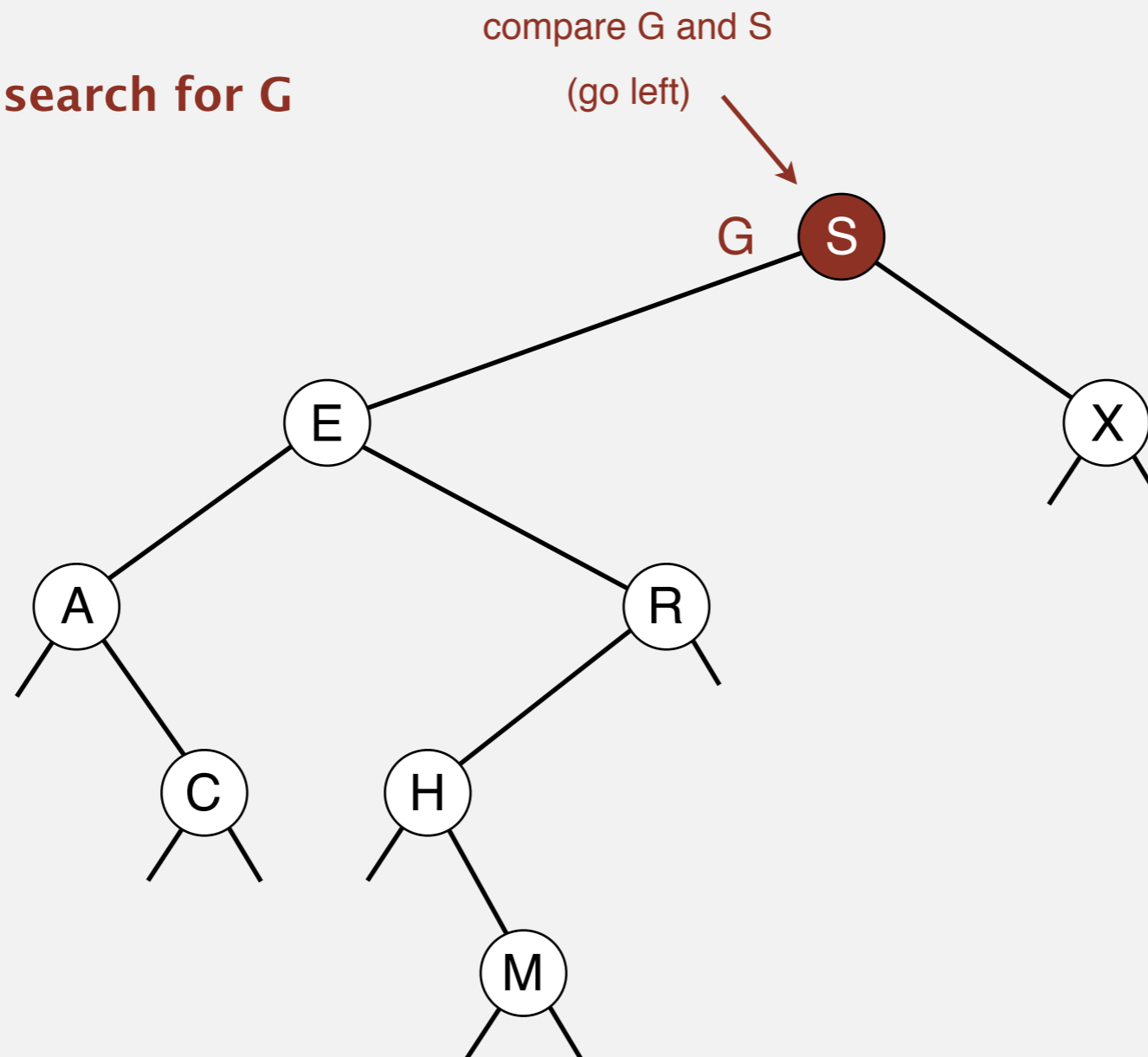

Binary search tree operations

Search. If less, go left; if greater, go right; if equal, search hit.

unsuccessful search for G

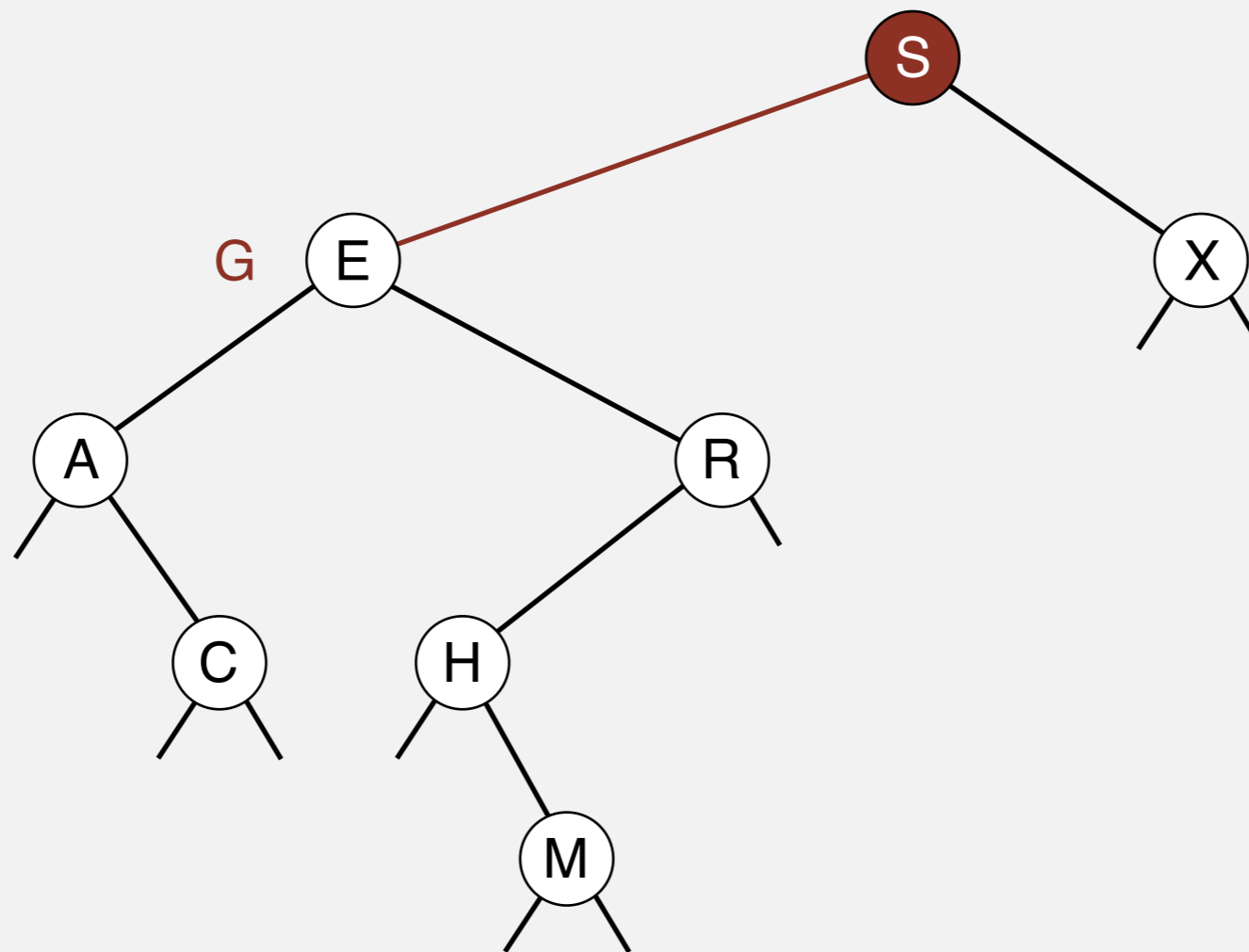

Binary search tree operations

Search. If less, go left; if greater, go right; if equal, search hit.

unsuccessful search for G

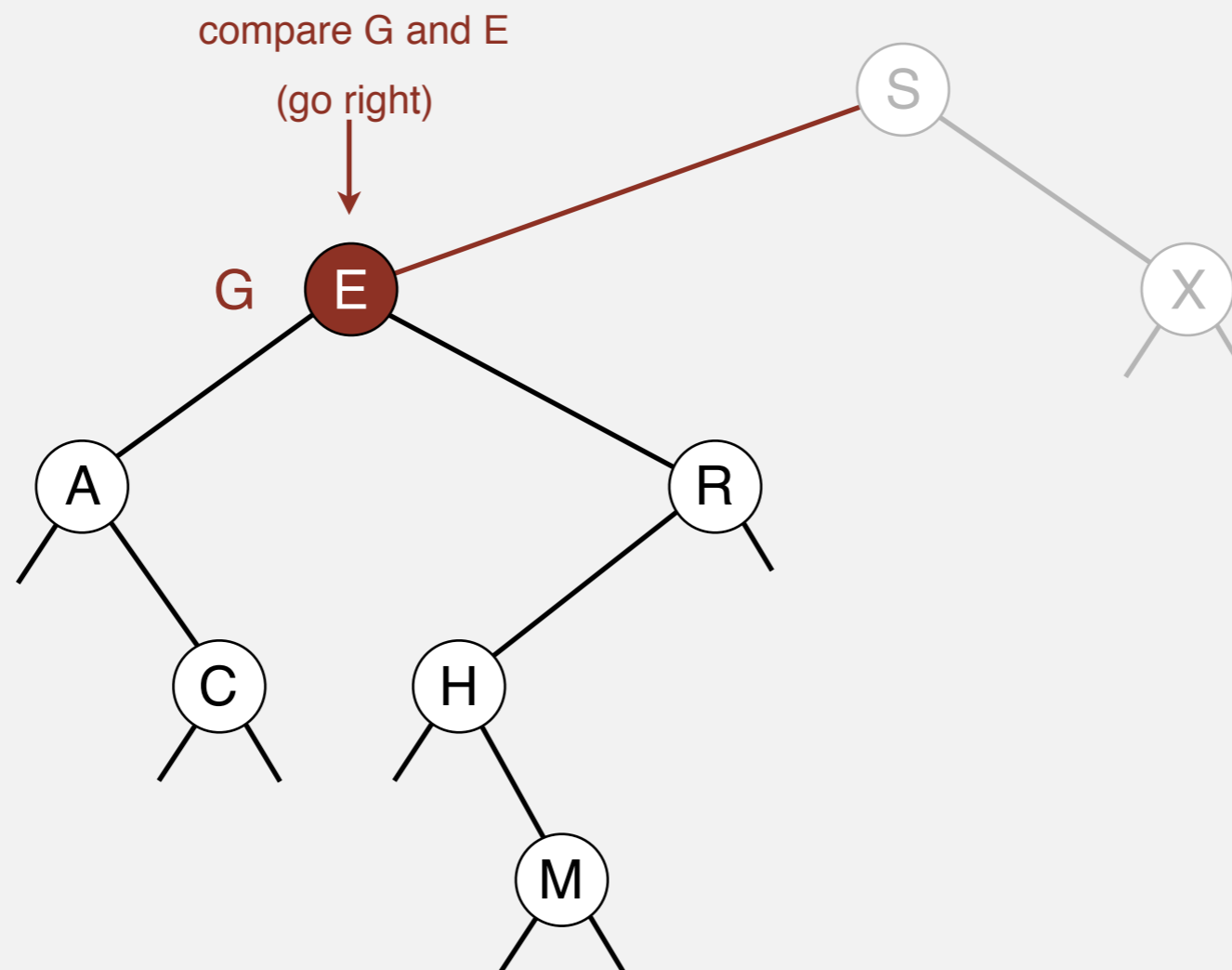

Binary search tree operations

Search. If less, go left; if greater, go right; if equal, search hit.

unsuccessful search for G

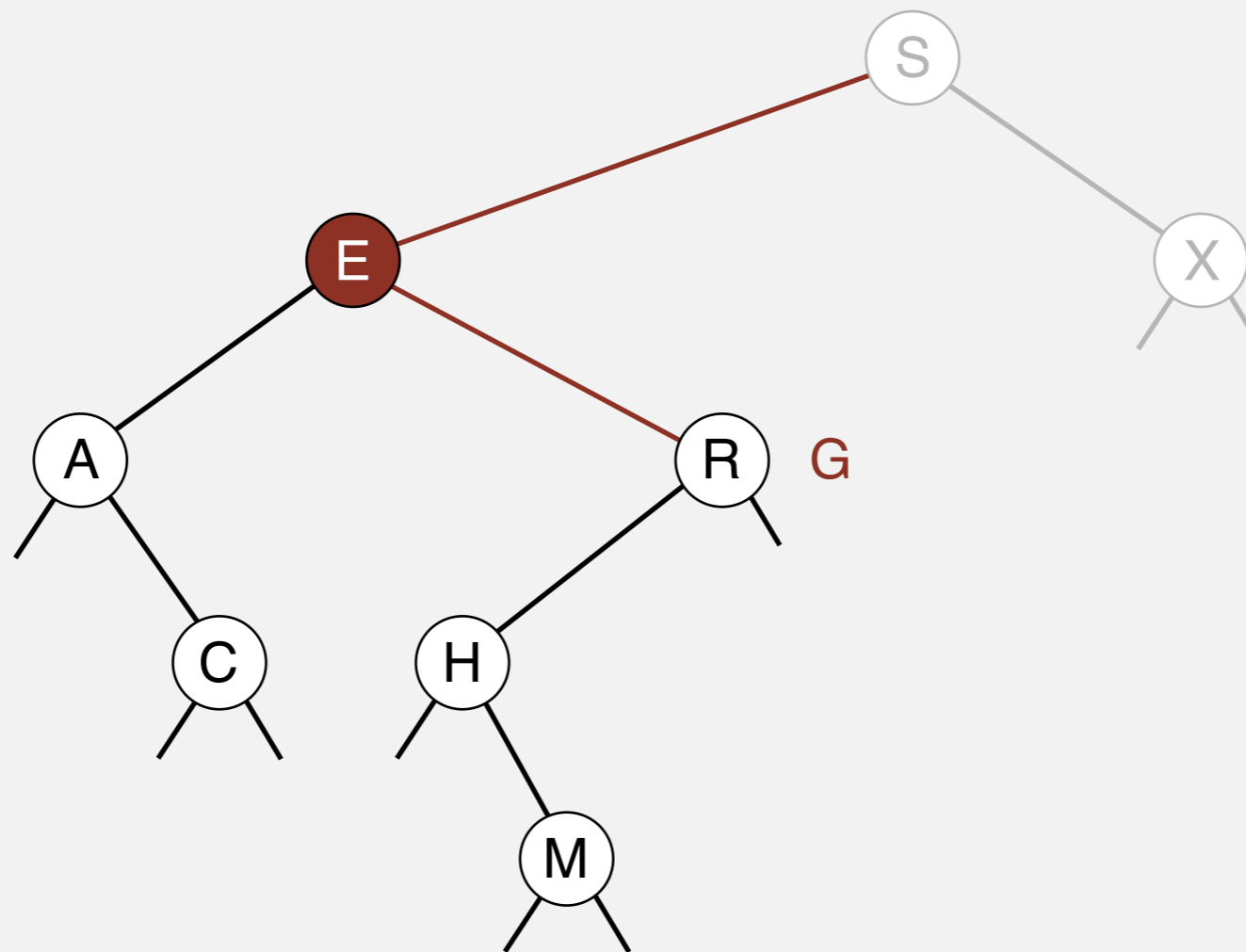

Binary search tree operations

Search. If less, go left; if greater, go right; if equal, search hit.

unsuccessful search for G

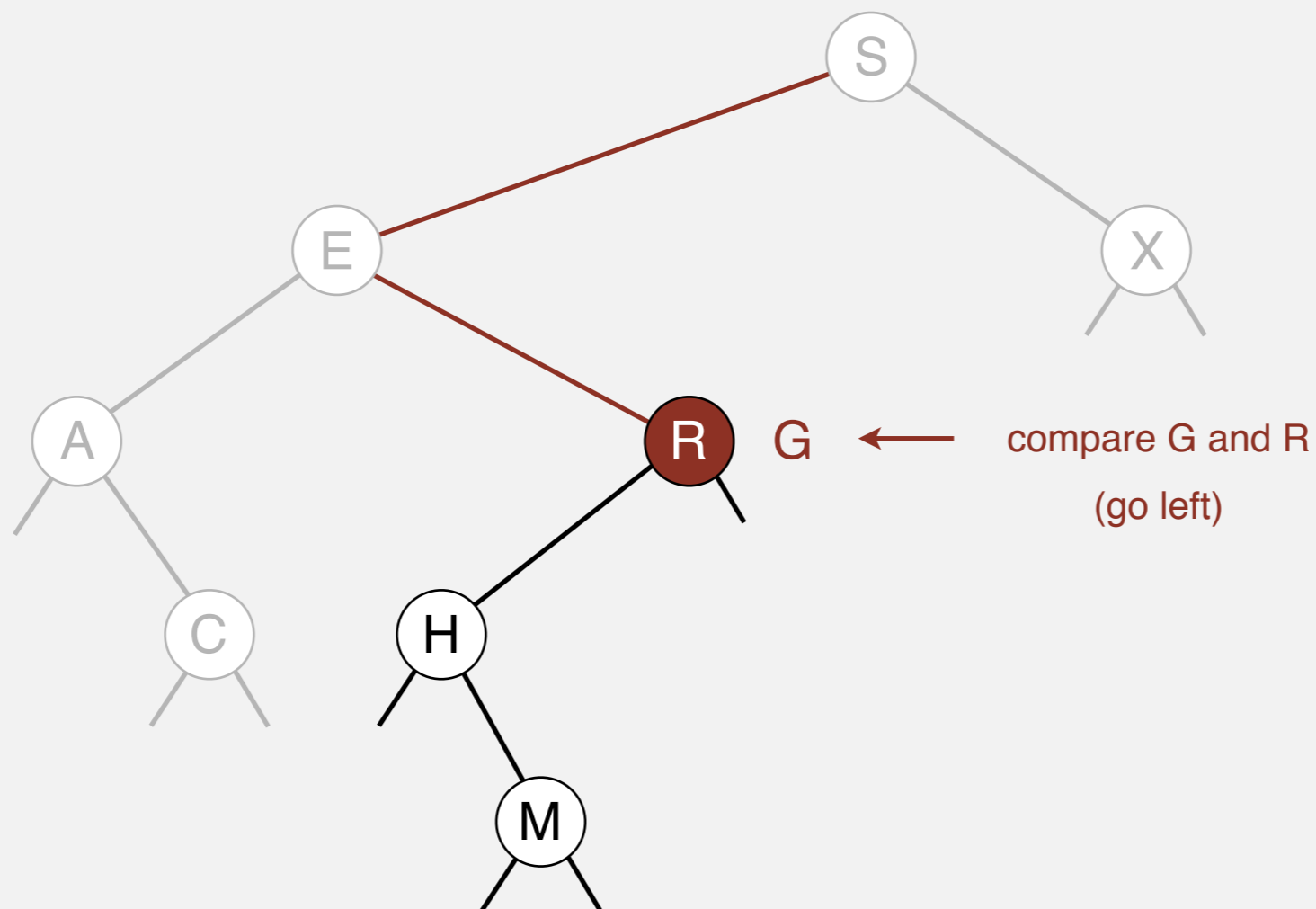

Binary search tree operations

Search. If less, go left; if greater, go right; if equal, search hit.

unsuccessful search for G

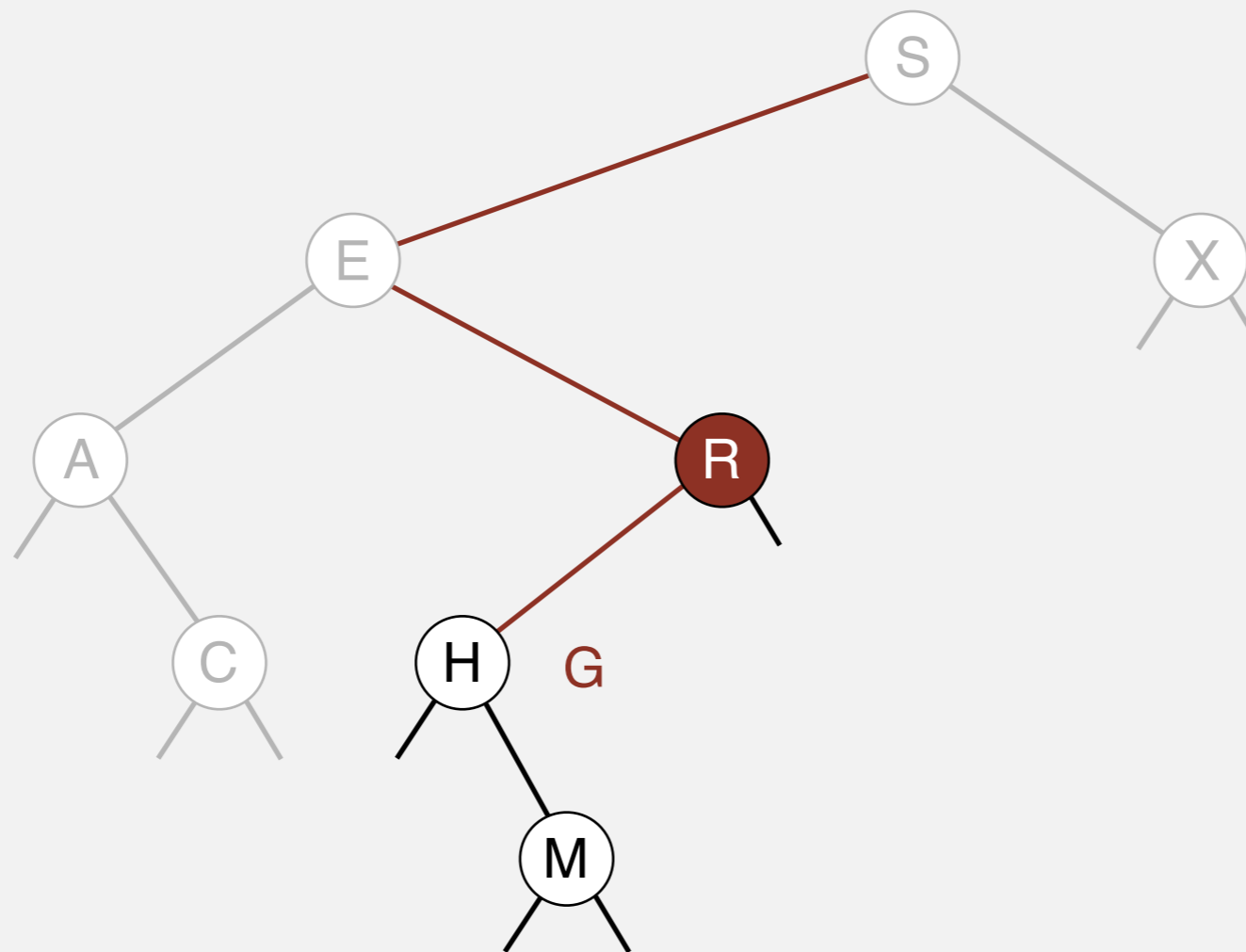

Binary search tree operations

Search. If less, go left; if greater, go right; if equal, search hit.

unsuccessful search for G

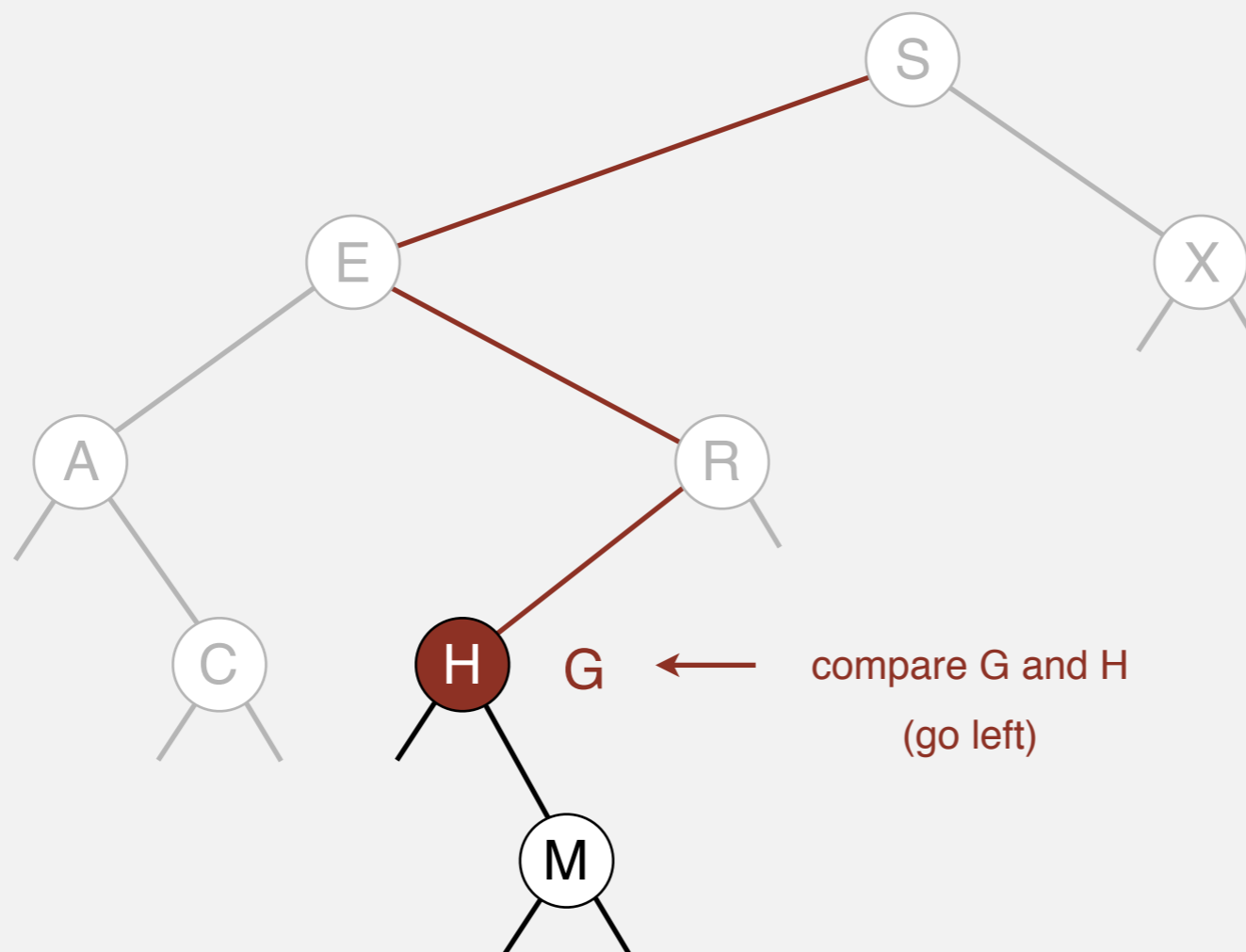

Binary search tree operations

Search. If less, go left; if greater, go right; if equal, search hit.

unsuccessful search for G

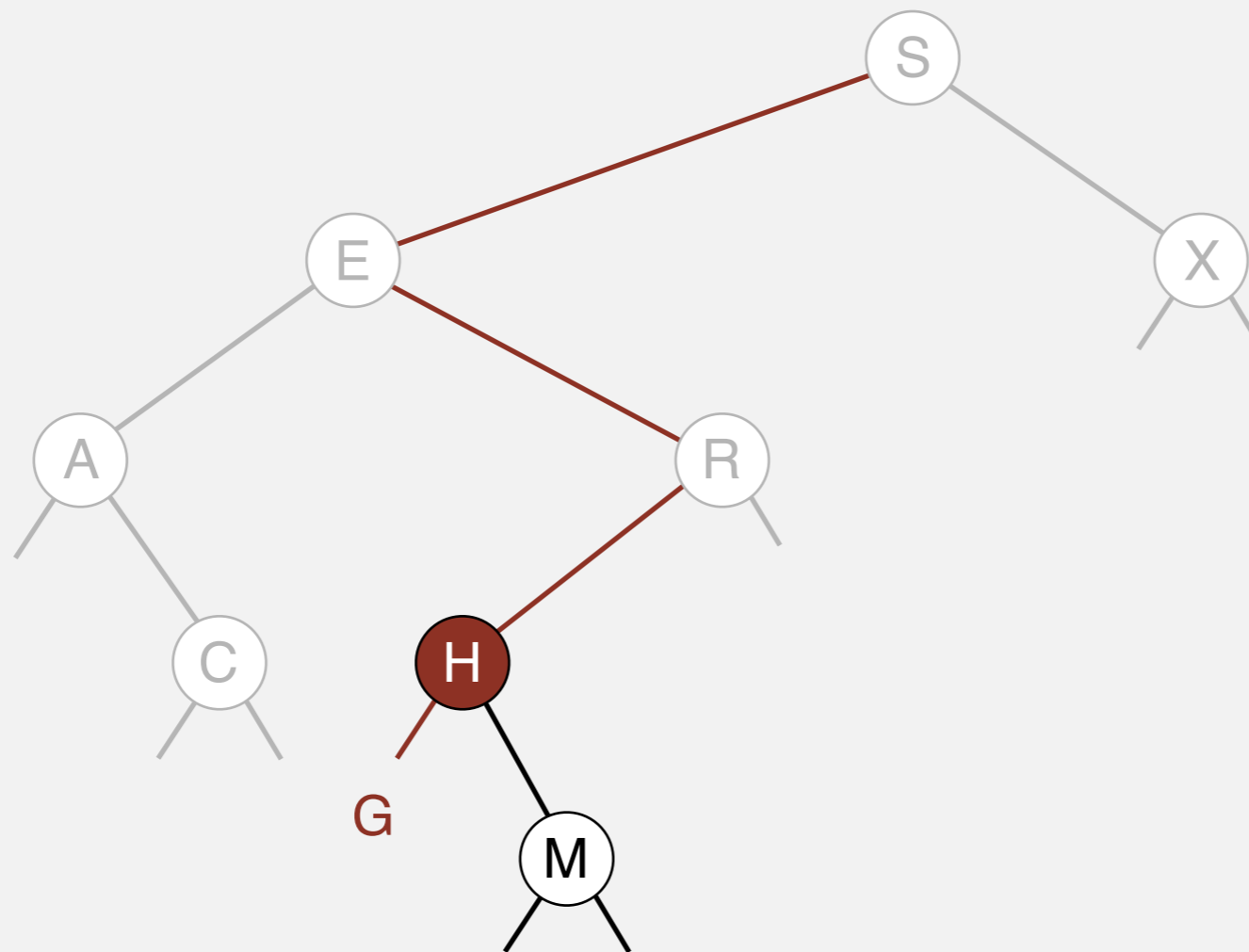

Binary search tree operations

Search. If less, go left; if greater, go right; if equal, search hit.

unsuccessful search for G

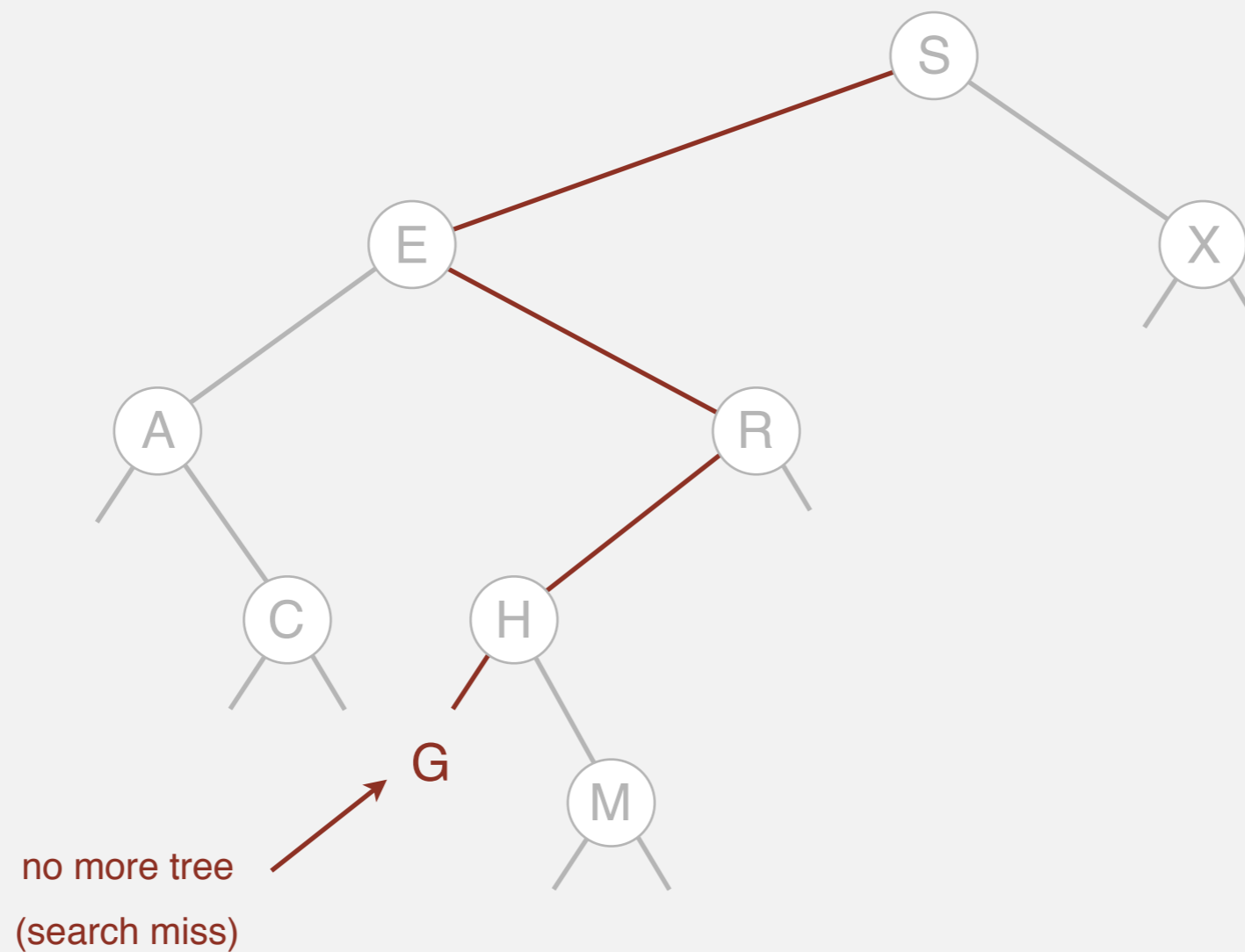

Binary search tree operations

Insert. If less, go left; if greater, go right; if null, insert.

insert G

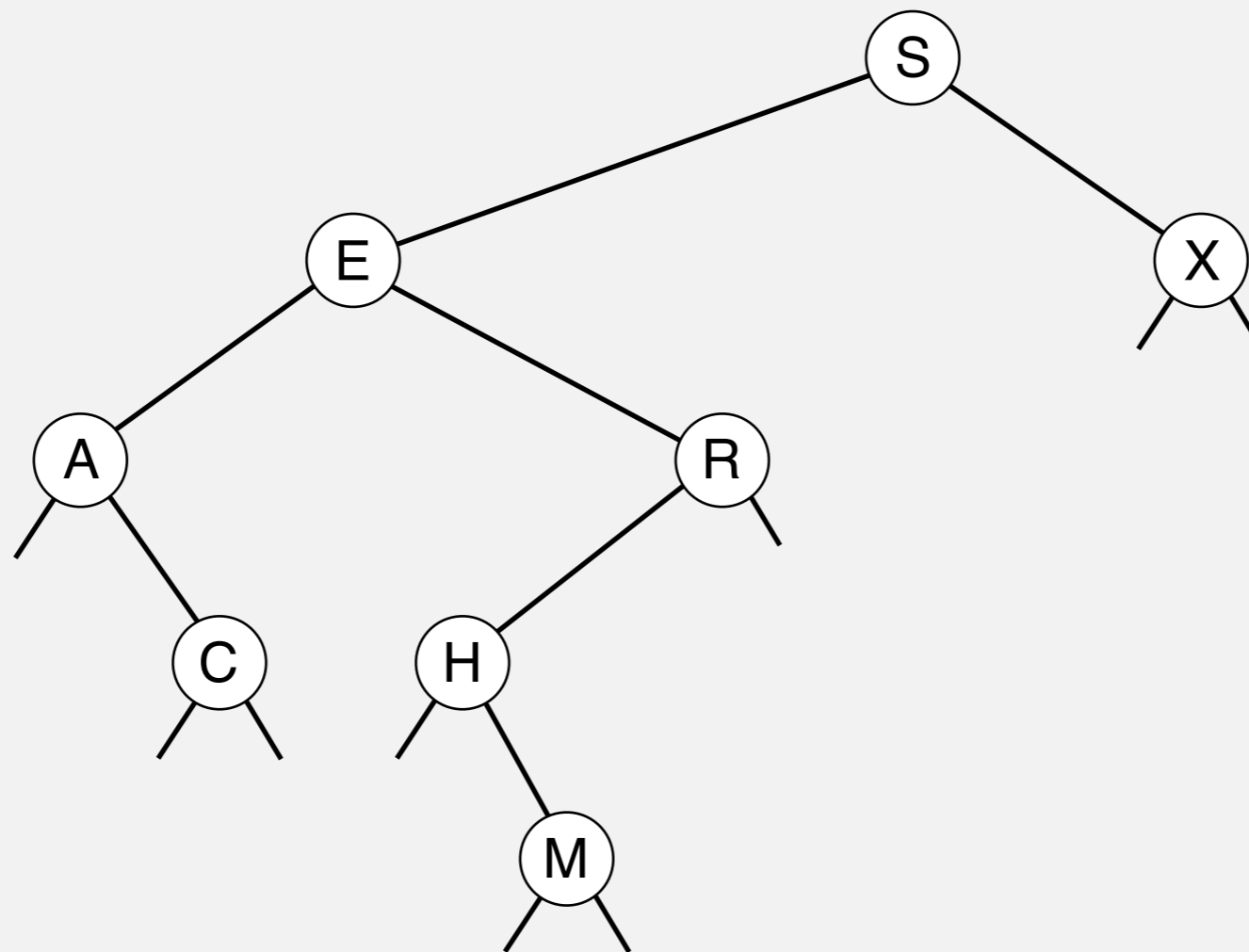

Binary search tree operations

Insert. If less, go left; if greater, go right; if null, insert.

insert G

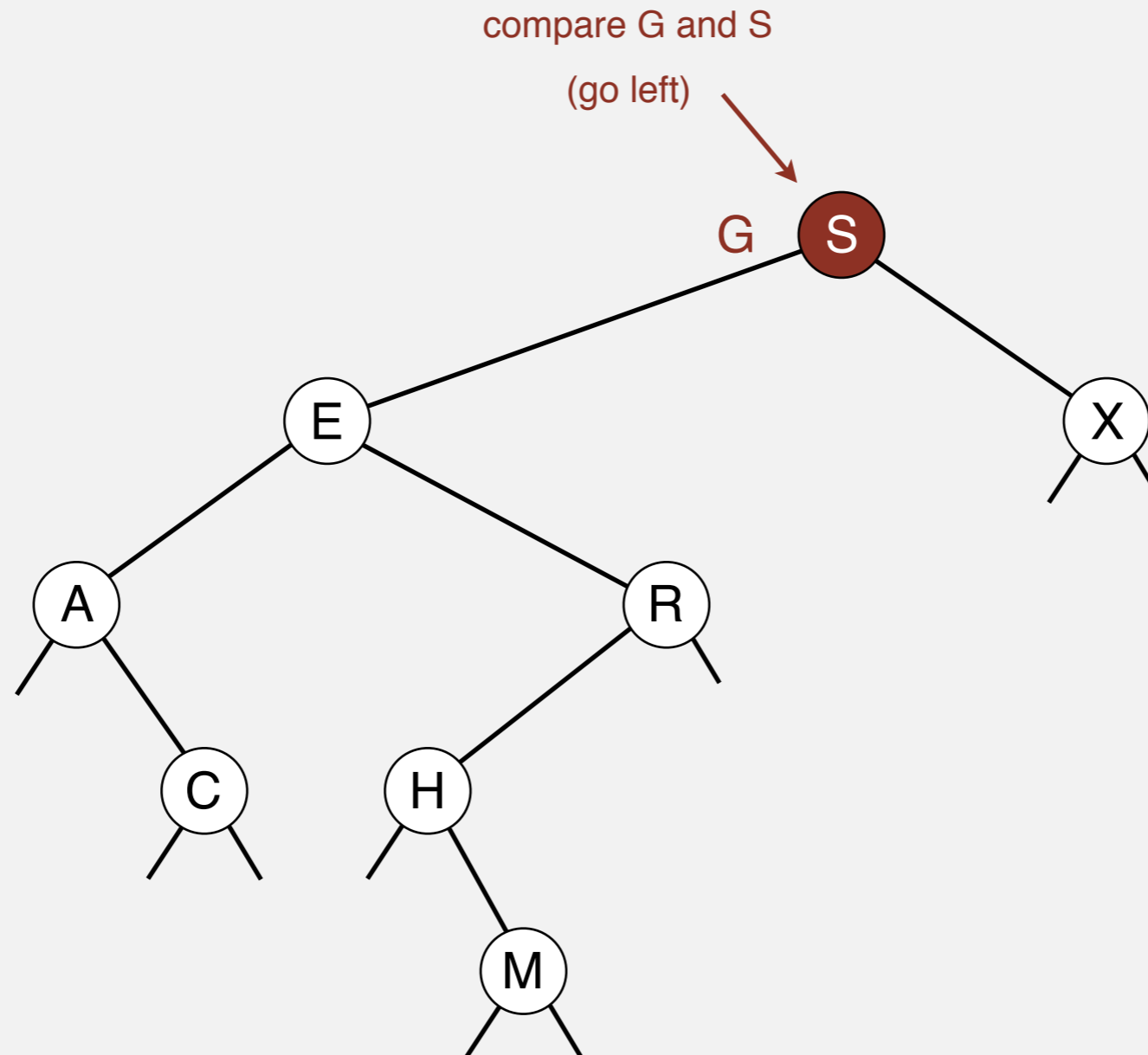

Binary search tree operations

Insert. If less, go left; if greater, go right; if null, insert.

insert G

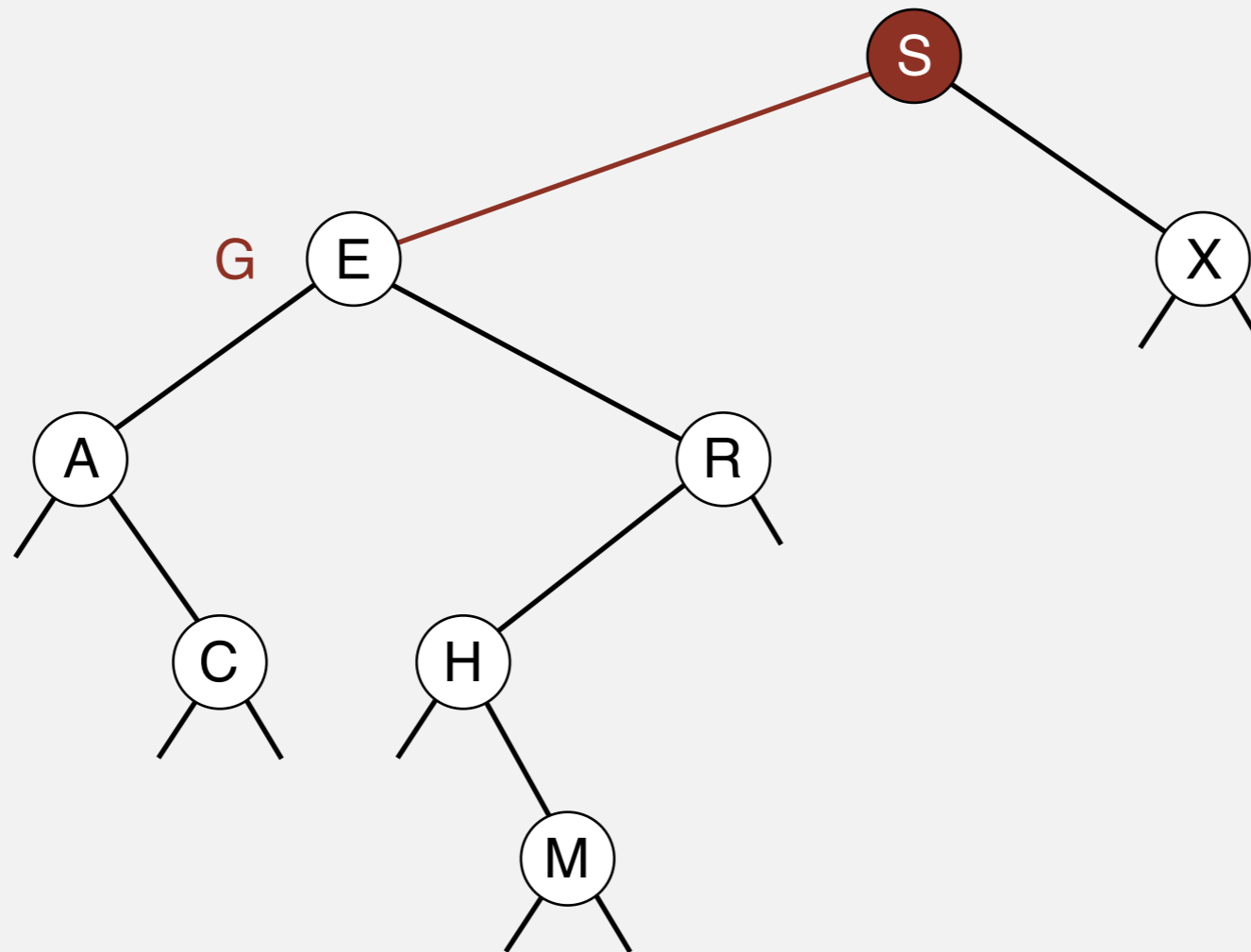

Binary search tree operations

Insert. If less, go left; if greater, go right; if null, insert.

insert G

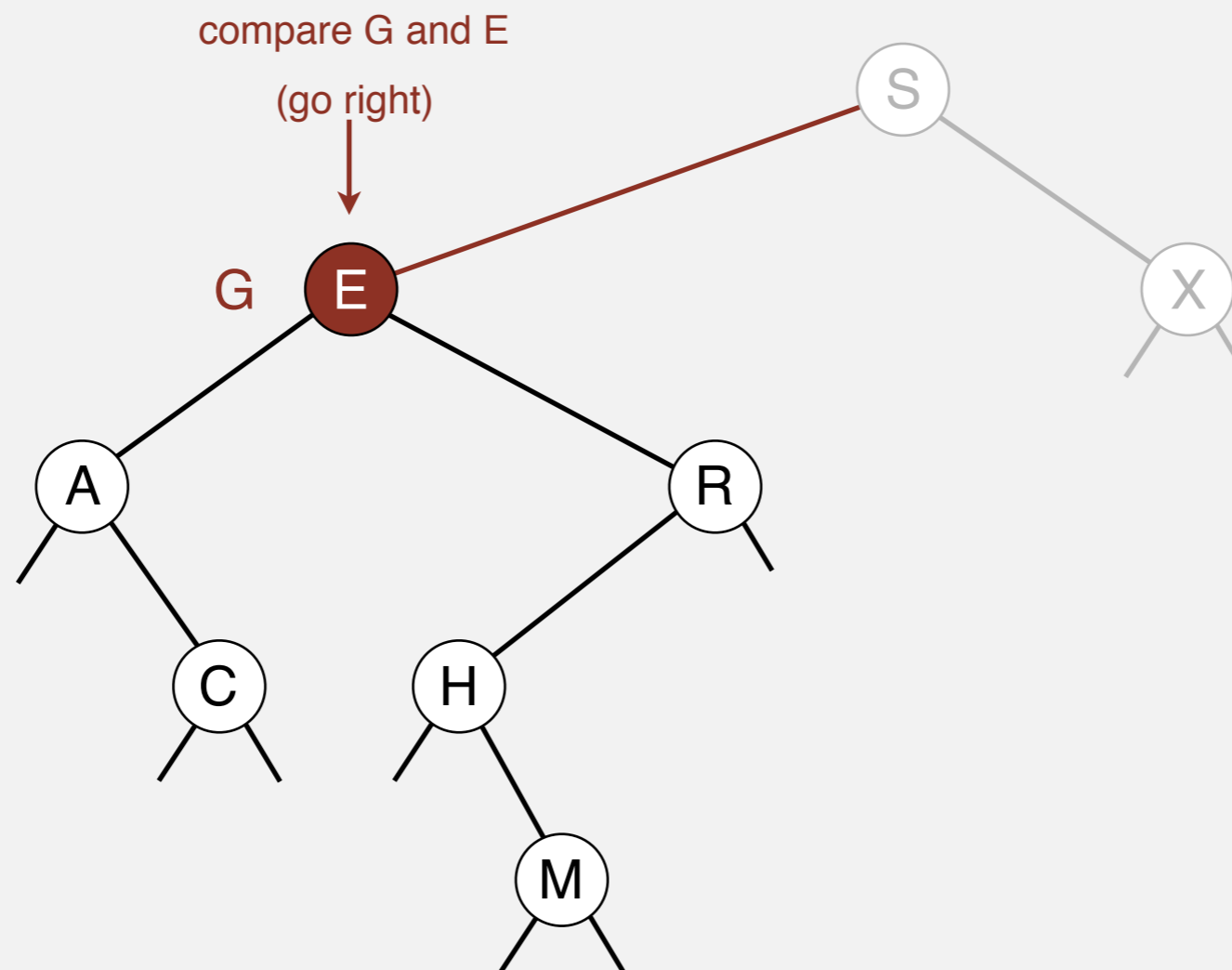

Binary search tree operations

Insert. If less, go left; if greater, go right; if null, insert.

insert G

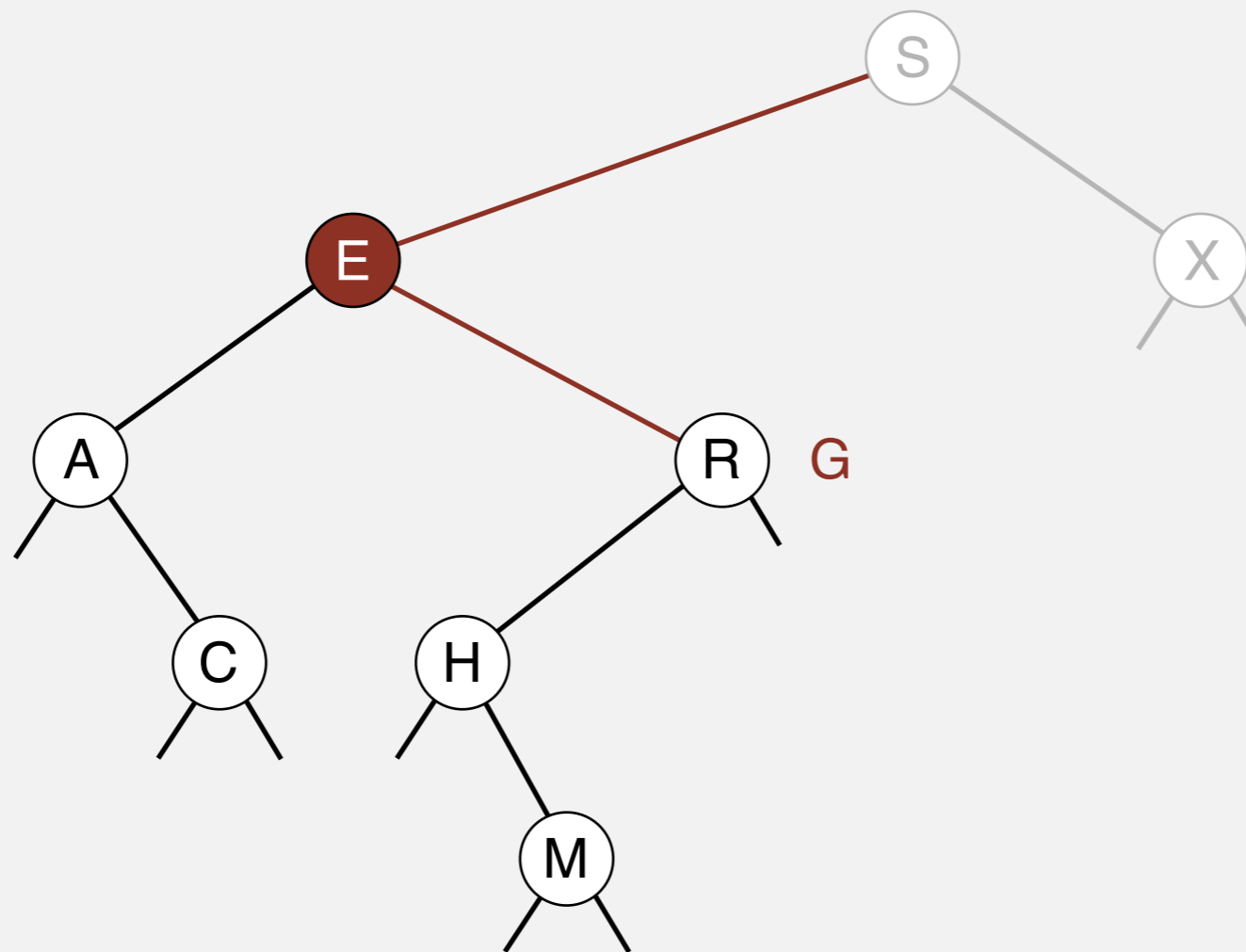

Binary search tree operations

Insert. If less, go left; if greater, go right; if null, insert.

insert G

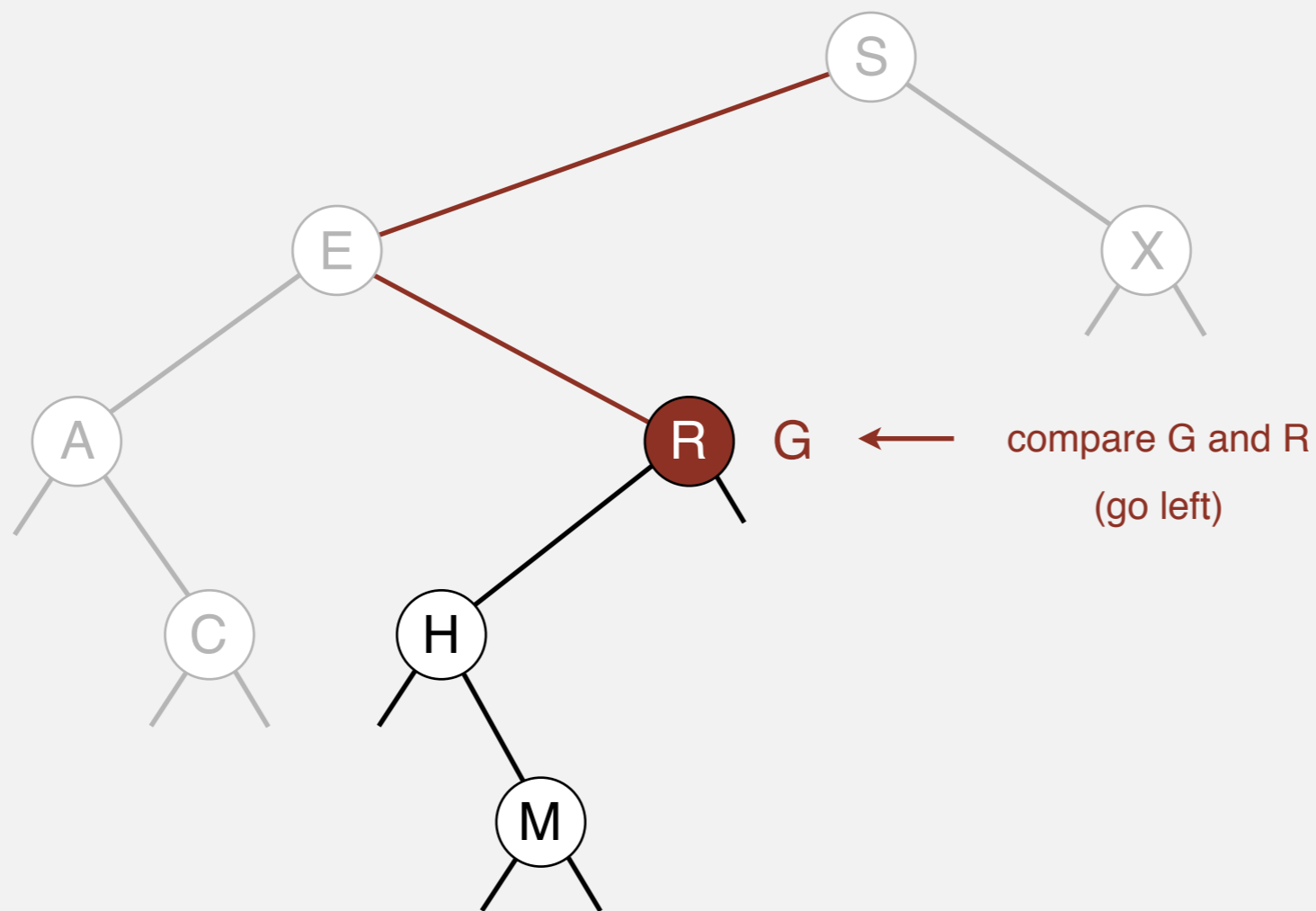

Binary search tree operations

Insert. If less, go left; if greater, go right; if null, insert.

insert G

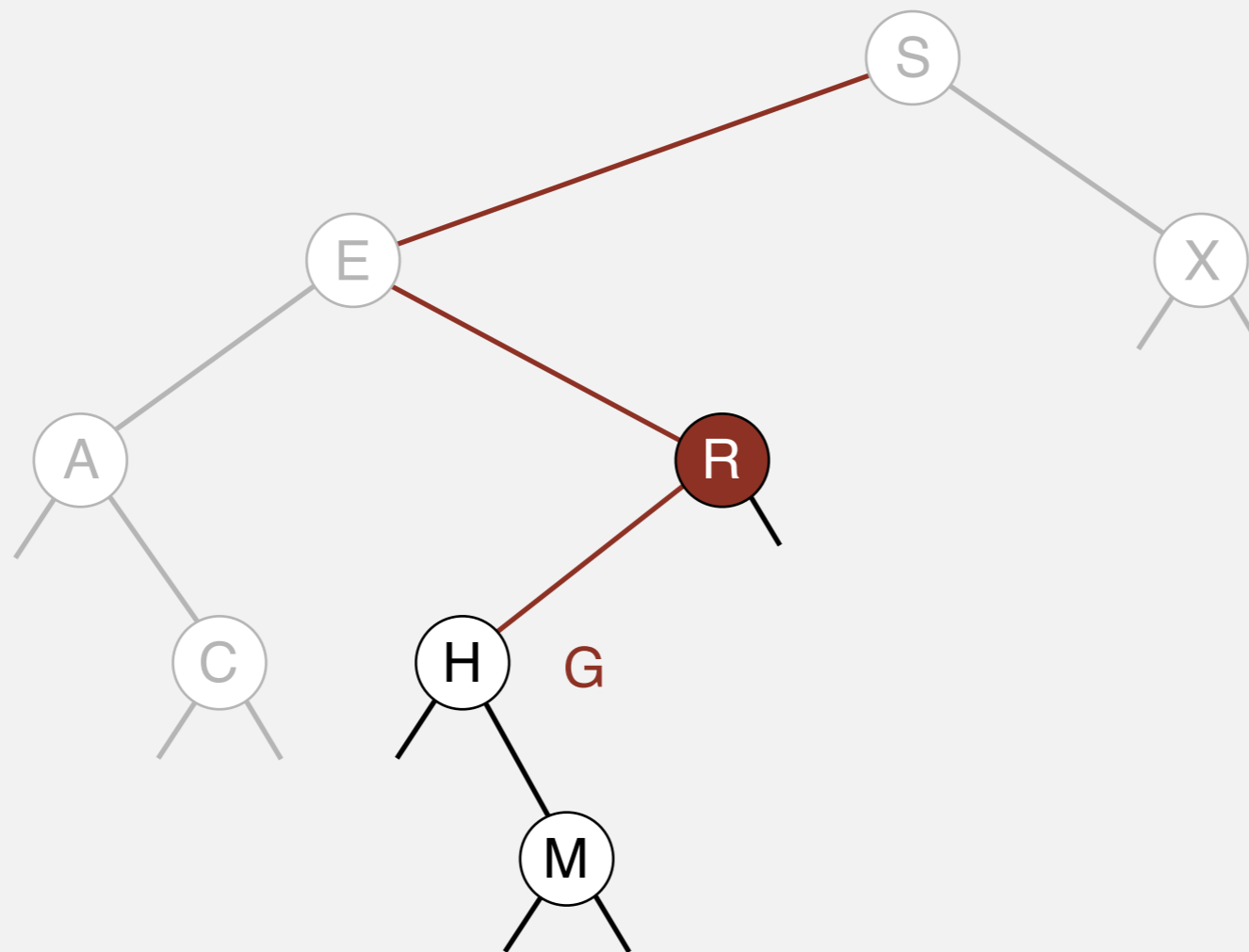

Binary search tree operations

Insert. If less, go left; if greater, go right; if null, insert.

insert G

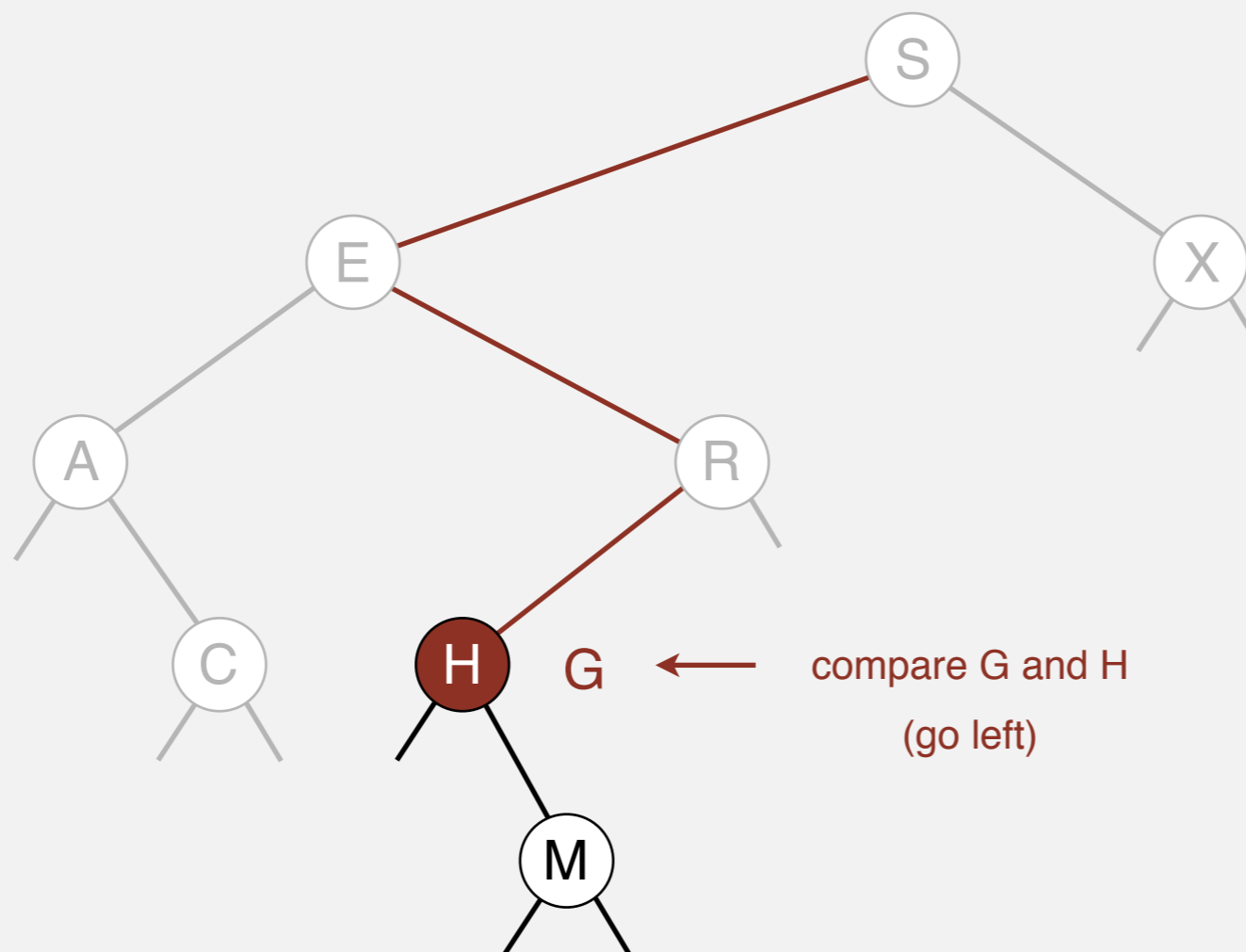

Binary search tree operations

Insert. If less, go left; if greater, go right; if null, insert.

insert G

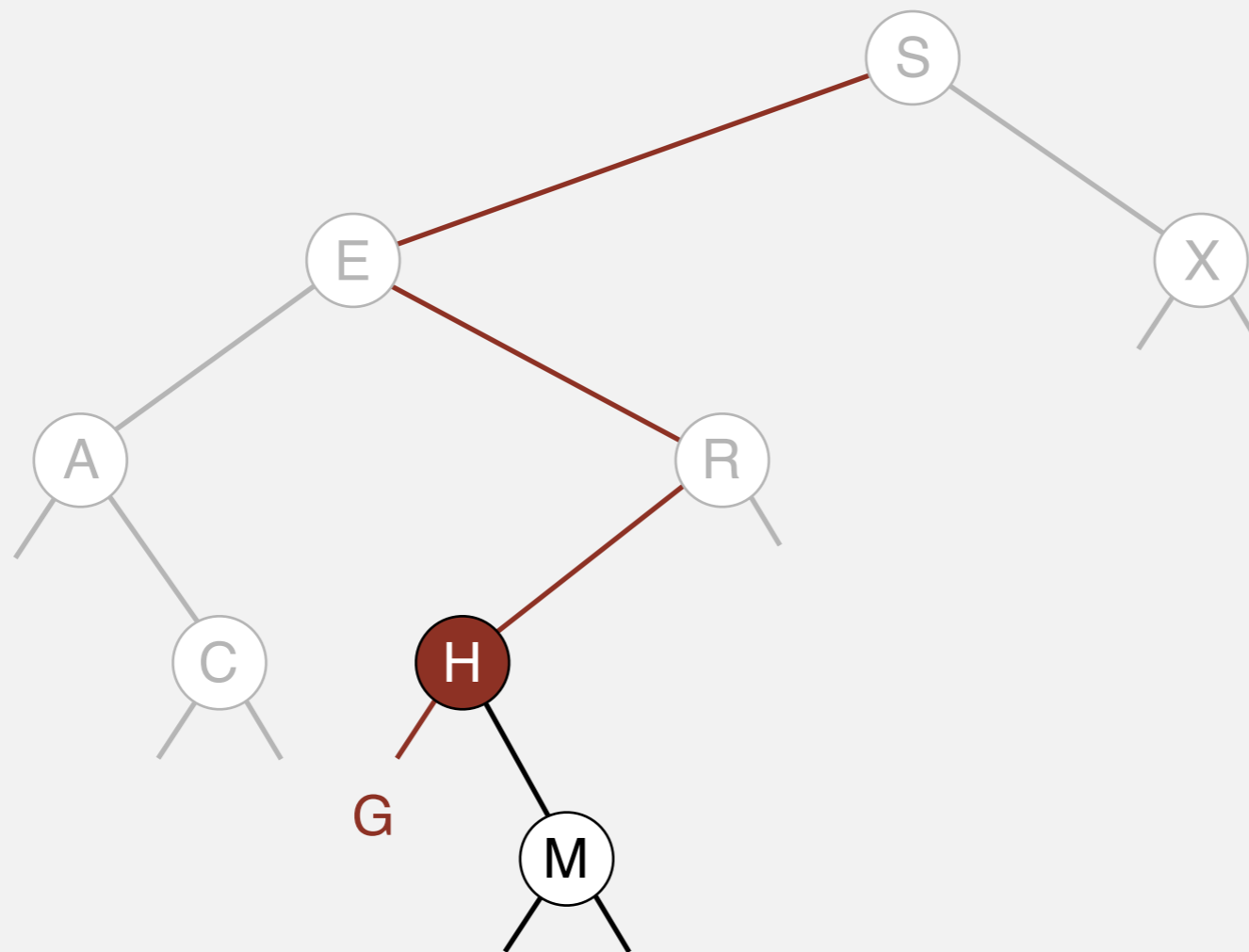

Binary search tree operations

Insert. If less, go left; if greater, go right; if null, insert.

insert G

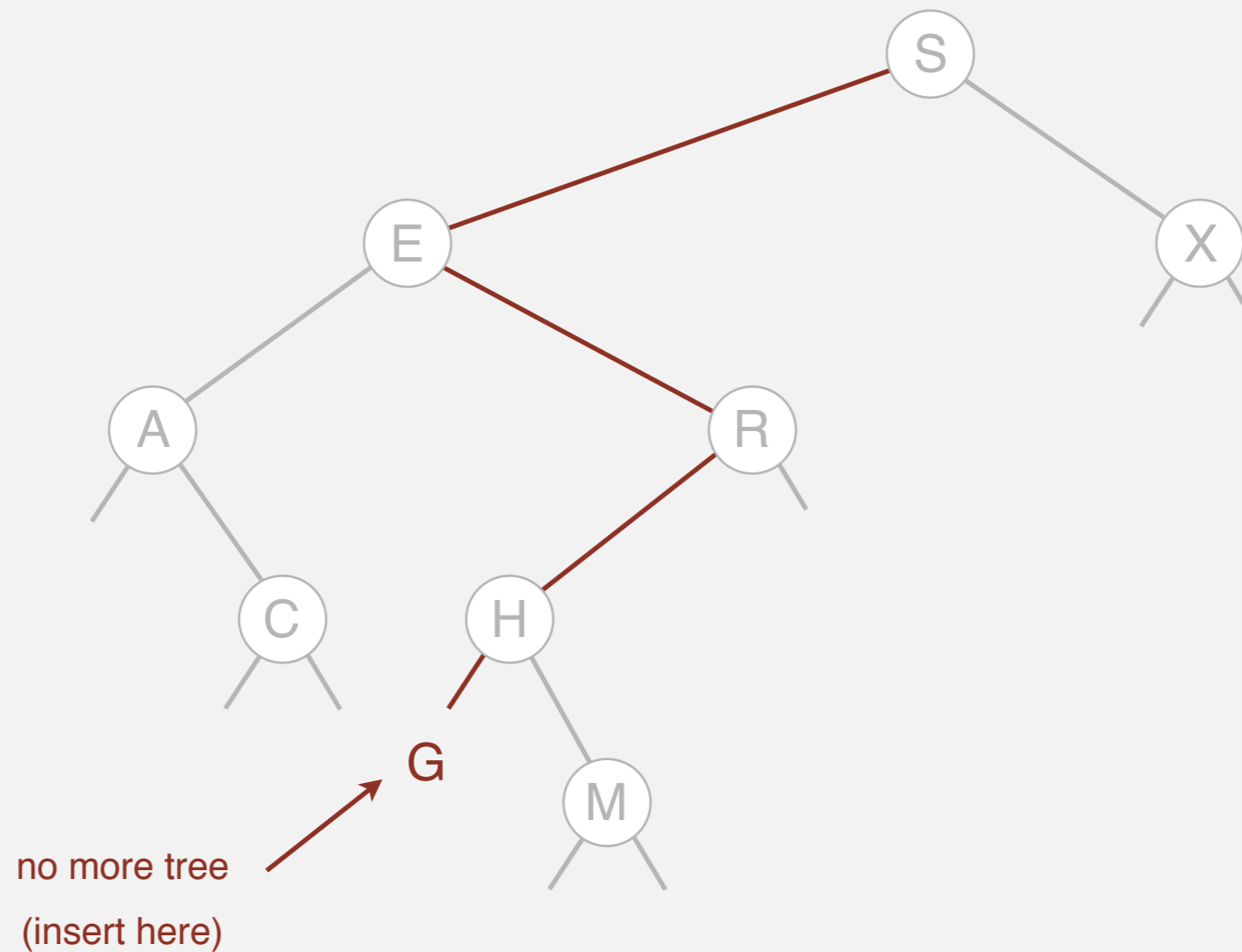

Binary search tree operations

Insert. If less, go left; if greater, go right; if null, insert.

insert G

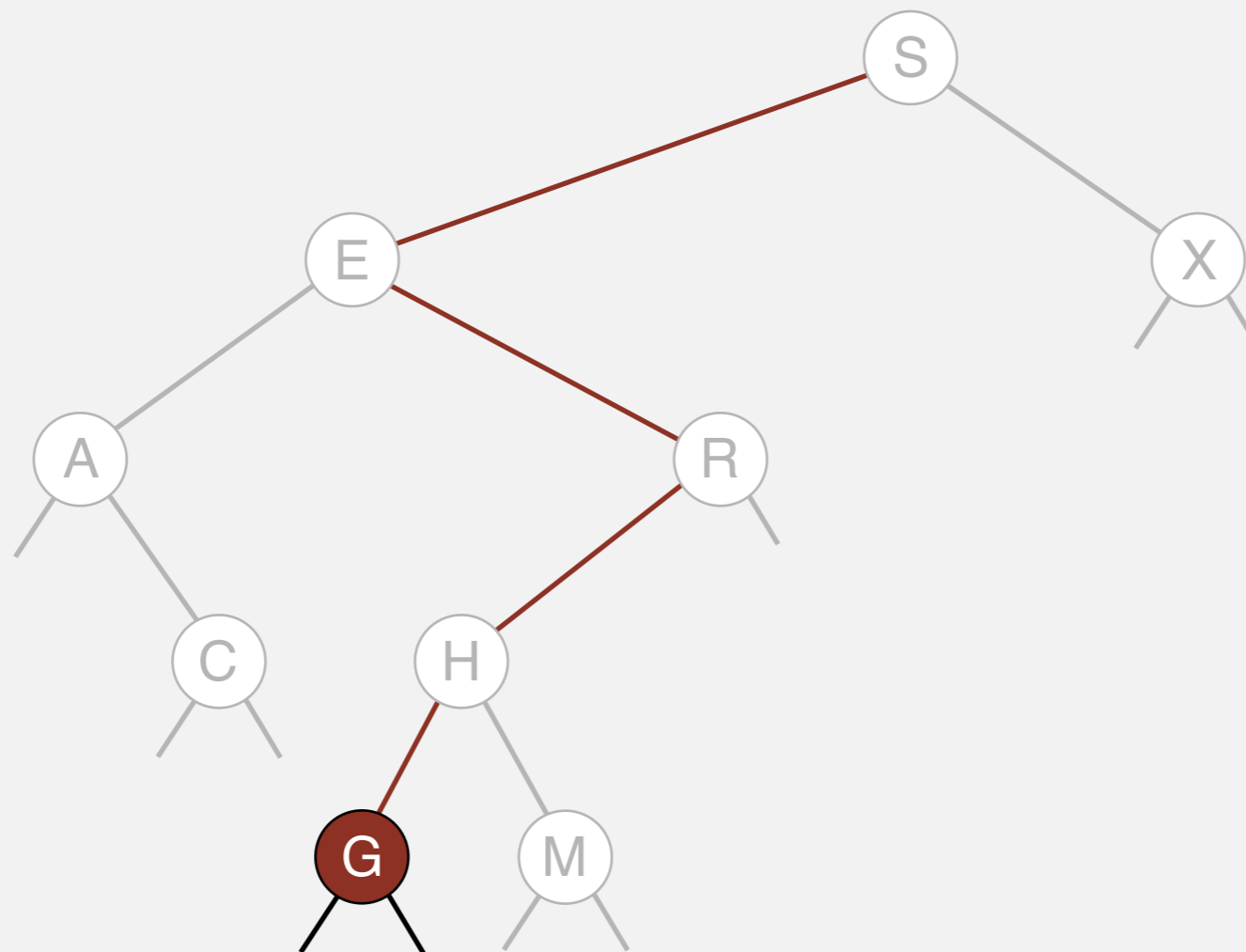

Binary search tree operations

Insert. If less, go left; if greater, go right; if null, insert.

insert G

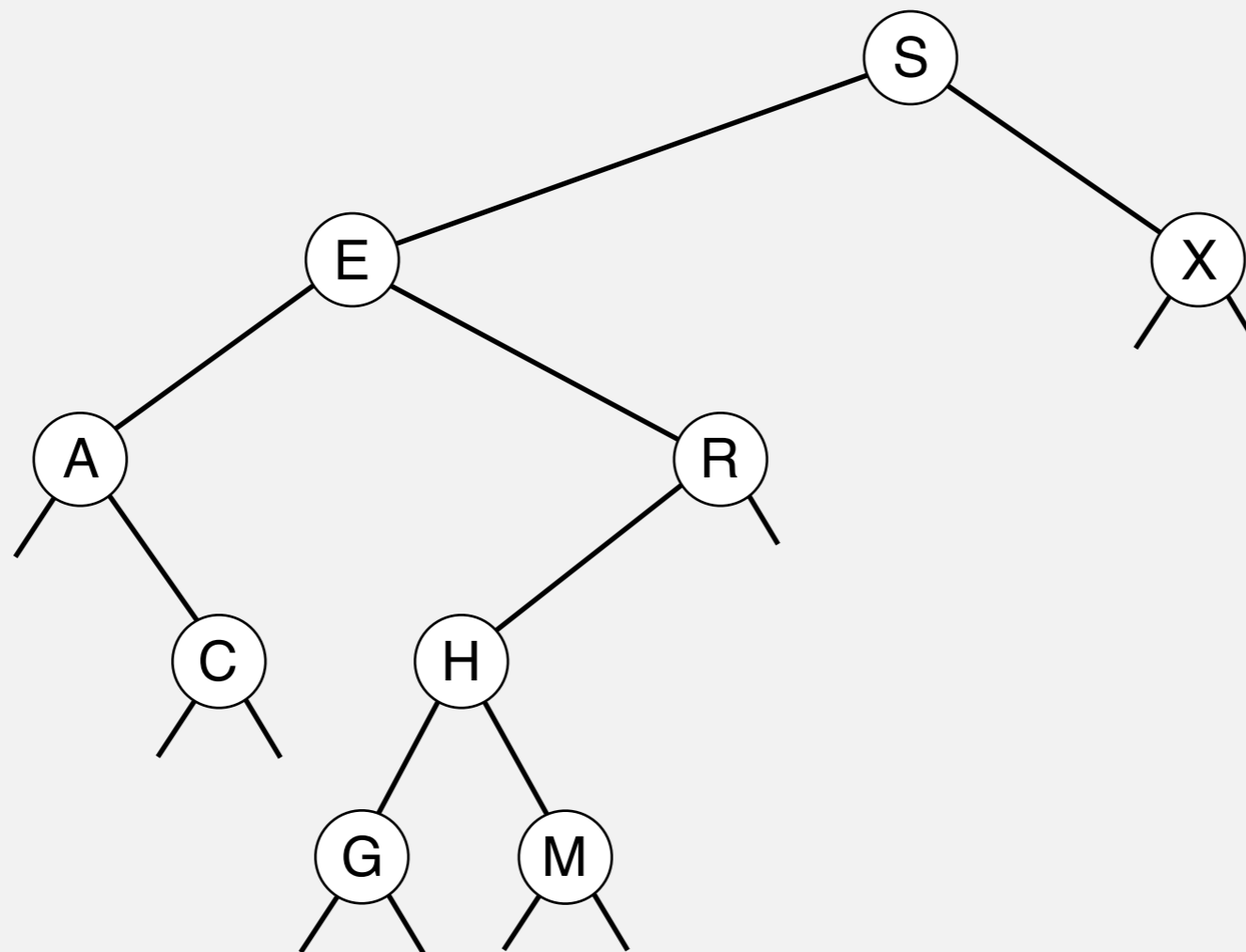

BST search

Get. Return value corresponding to given key, or `null` if no such key.

successful search for R

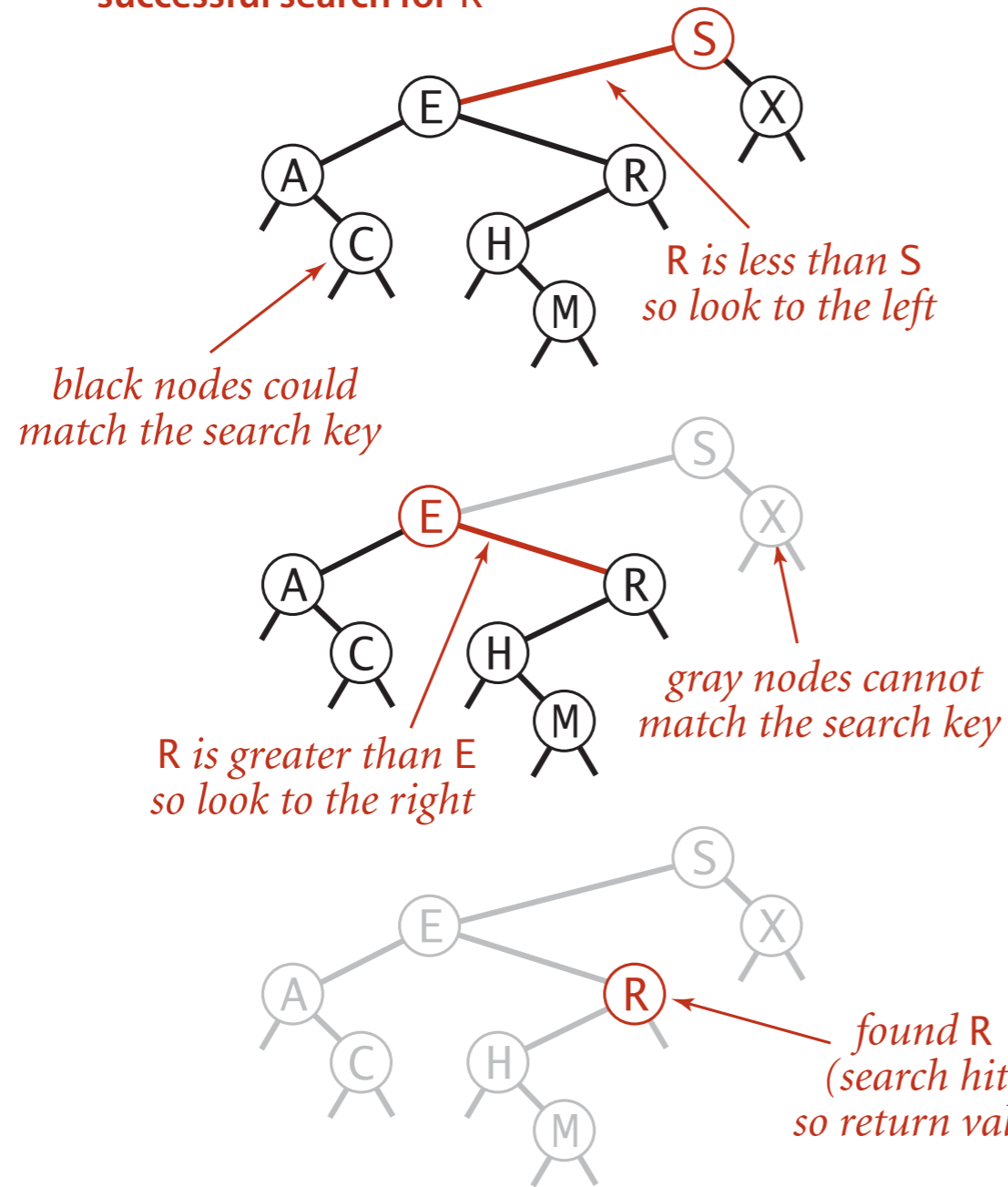

unsuccessful search for T

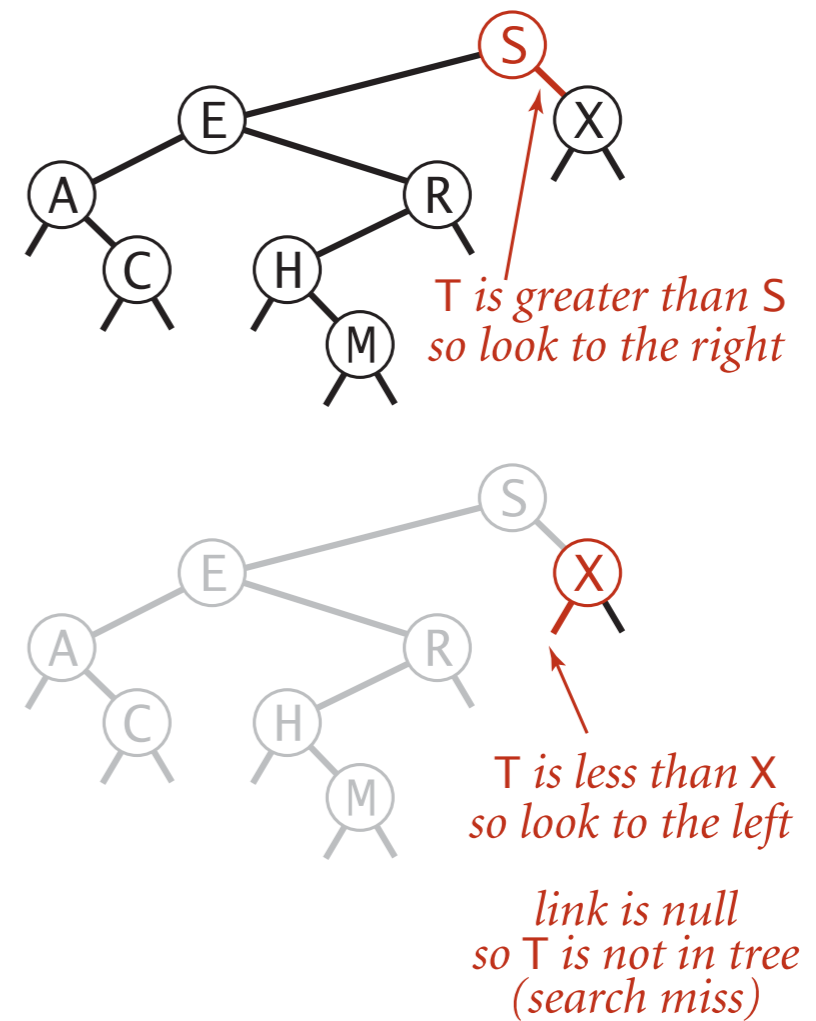

BST search: Java implementation

Get. Return value corresponding to given key, or `null` if no such key.

```
public Value get(Key key)
{
    Node x = root;
    while (x != null)
    {
        int cmp = key.compareTo(x.key);
        if (cmp < 0) x = x.left;
        else if (cmp > 0) x = x.right;
        else if (cmp == 0) return x.val;
    }
    return null;
}
```

Cost. Number of compares is equal to $1 + \text{depth of node}$.

BST insert

Put. Associate value with key.

Search for key, then two cases:

- Key in tree \Rightarrow reset value.
- Key not in tree \Rightarrow add new node.

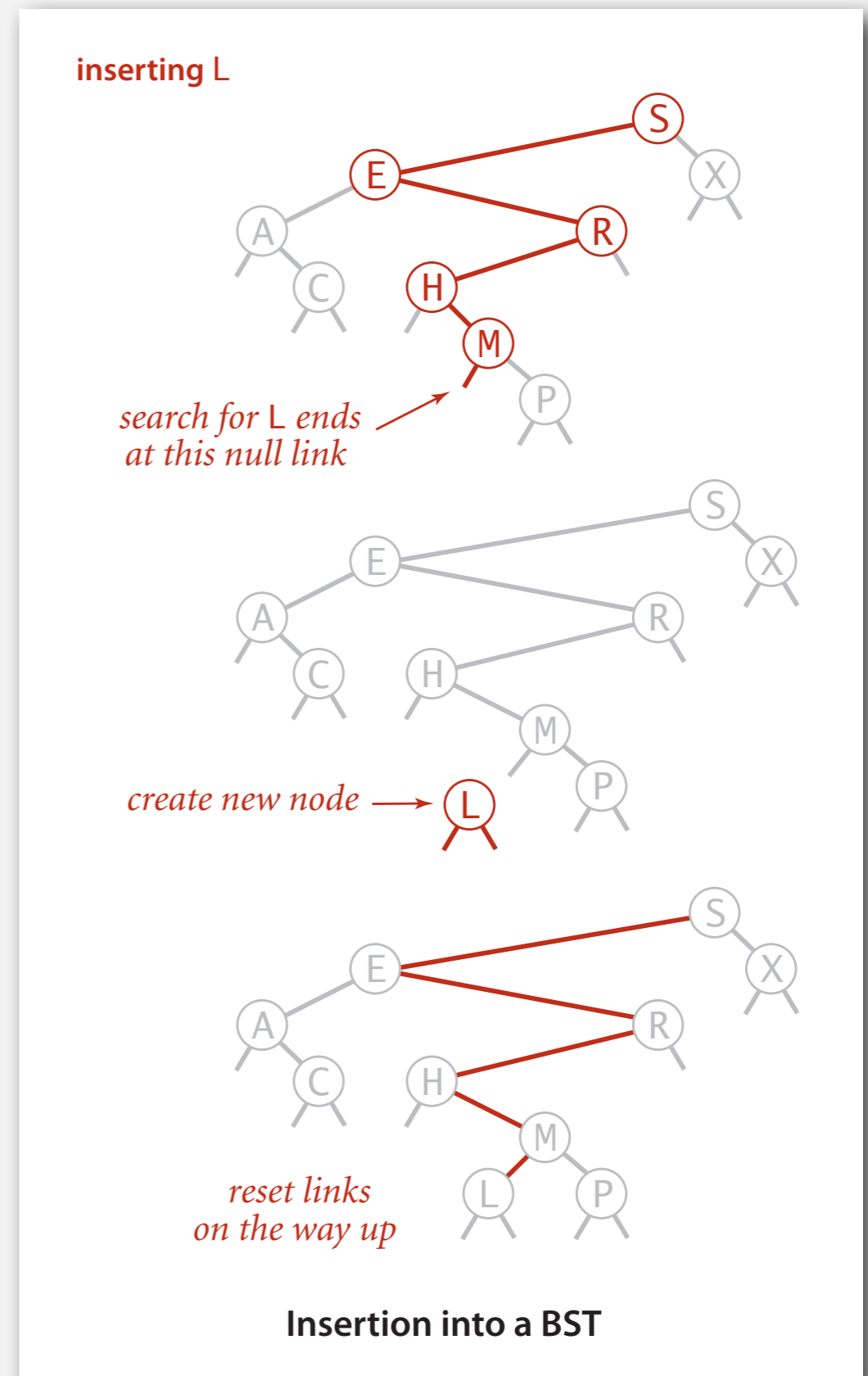

BST insert: Java implementation

Put. Associate value with key.

```
public void put(Key key, Value val)
{ root = put(root, key, val); }

private Node put(Node x, Key key, Value val)
{
    if (x == null) return new Node(key, val);
    int cmp = key.compareTo(x.key);
    if (cmp < 0)
        x.left = put(x.left, key, val);
    else if (cmp > 0)
        x.right = put(x.right, key, val);
    else if (cmp == 0)
        x.val = val;
    return x;
}
```

concise, but tricky,
recursive code;
read carefully!

Always assign the subtree
returned from recursive
call to a child, but does it actually
change in each call ?

Cost. Number of compares is equal to $1 + \text{depth of node}$.

BST trace: standard indexing client

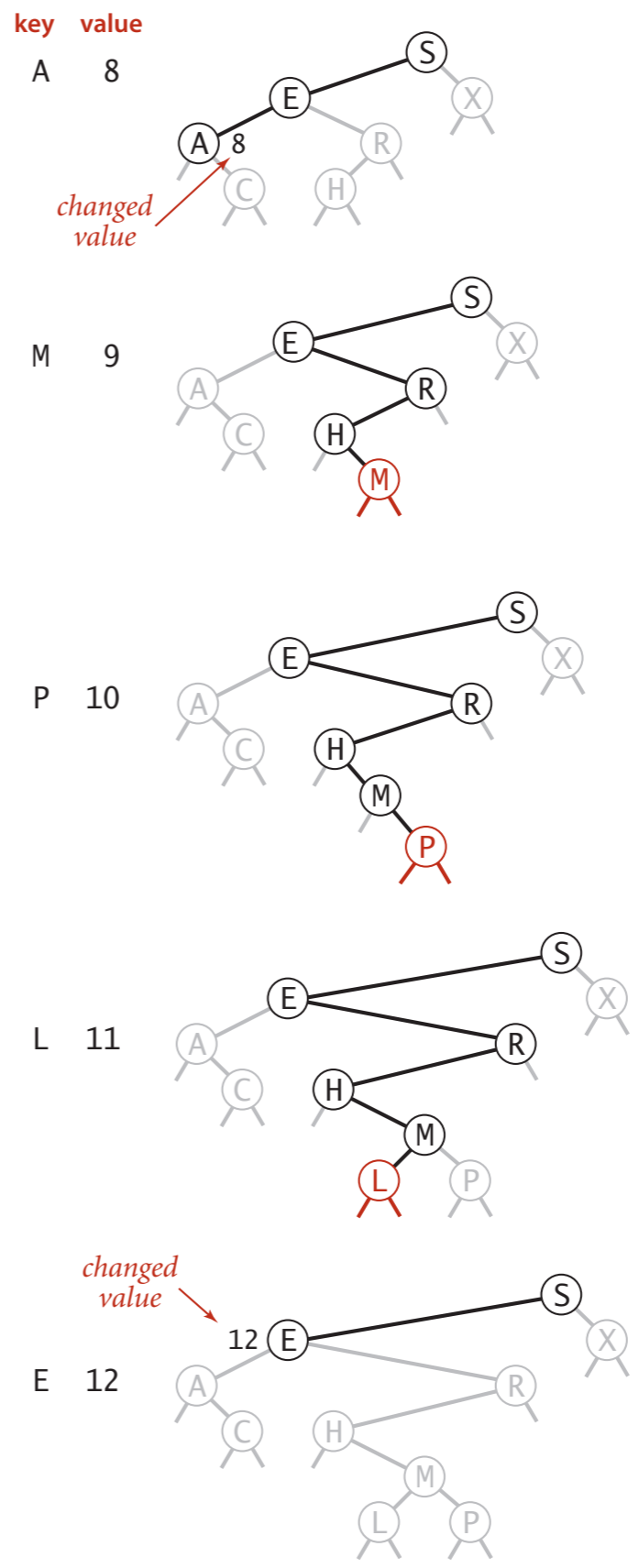
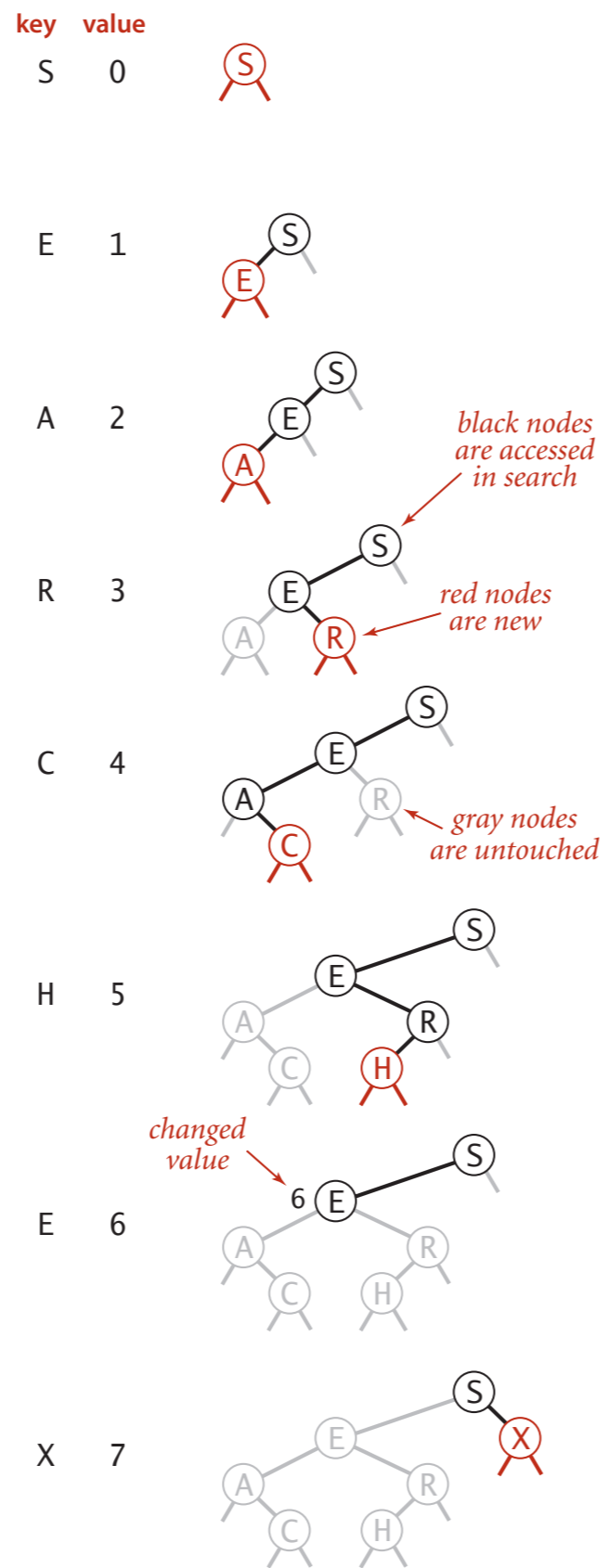

Tree shape

- Many BSTs correspond to same set of keys.
- Number of compares for search/insert is equal to $1 + \text{depth of node}$.

best case

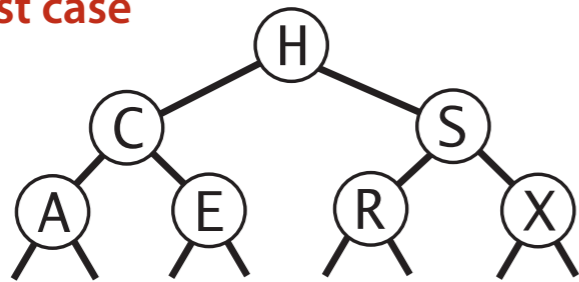

typical case

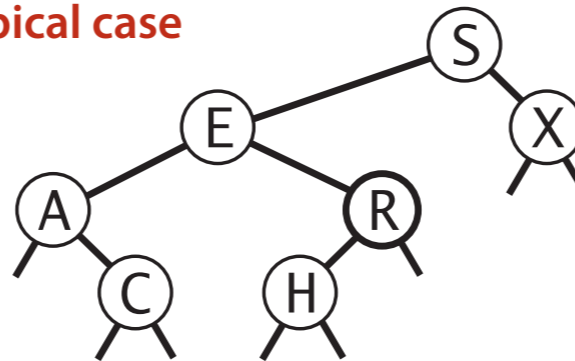

worst case

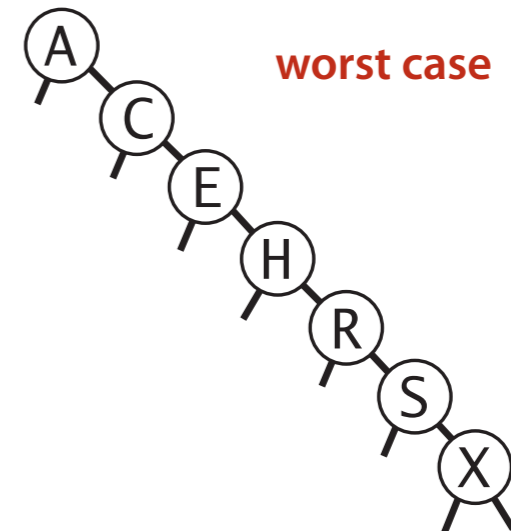

Remark. Tree shape depends on order of insertion.

BST insertion: random order visualization

Ex. Insert keys in random order.

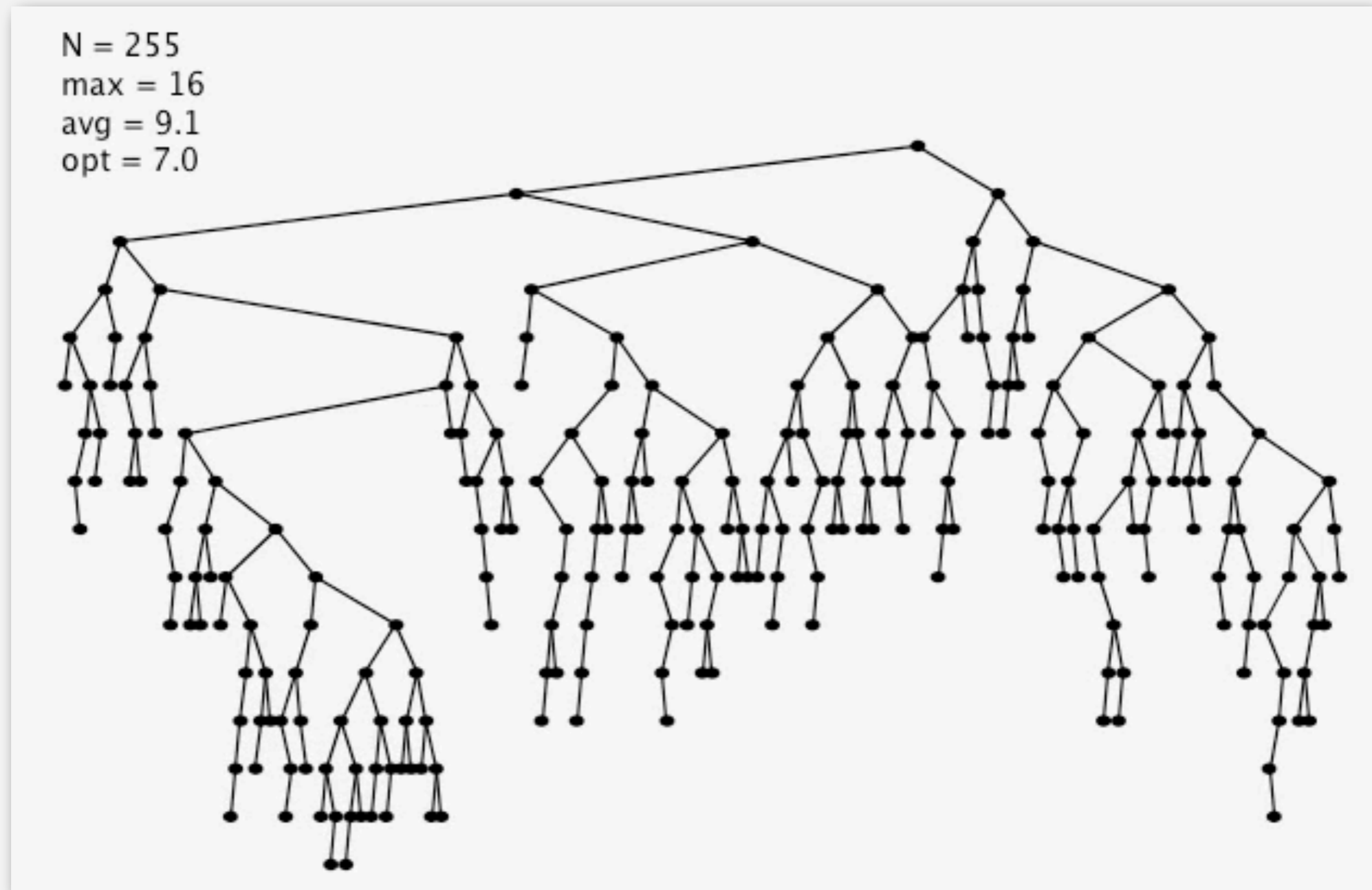

Correspondence between BSTs and quicksort partitioning

0	1	2	3	4	5	6	7	8	9	10	11	12	13
P	S	E	U	D	O	M	Y	T	H	I	C	A	L
P	S	E	U	D	O	M	Y	T	H	I	C	A	L
H	L	E	A	D	O	M	C	I	P	T	Y	U	S
D	C	E	A	H	O	M	L	I	P	T	Y	U	S
A	C	D	E	H	O	M	L	I	P	T	Y	U	S
A	C	D	E	H	O	M	L	I	P	T	Y	U	S
A	C	D	E	H	O	M	L	I	P	T	Y	U	S
A	C	D	E	H	O	M	L	I	P	T	Y	U	S
A	C	D	E	H	I	M	L	O	P	T	Y	U	S
A	C	D	E	H	I	M	L	O	P	T	Y	U	S
A	C	D	E	H	I	L	M	O	P	T	Y	U	S
A	C	D	E	H	I	L	M	O	P	S	T	U	Y
A	C	D	E	H	I	L	M	O	P	S	T	U	Y
A	C	D	E	H	I	L	M	O	P	S	T	U	Y
A	C	D	E	H	I	L	M	O	P	S	T	U	Y
A	C	D	E	H	I	L	M	O	P	S	T	U	Y

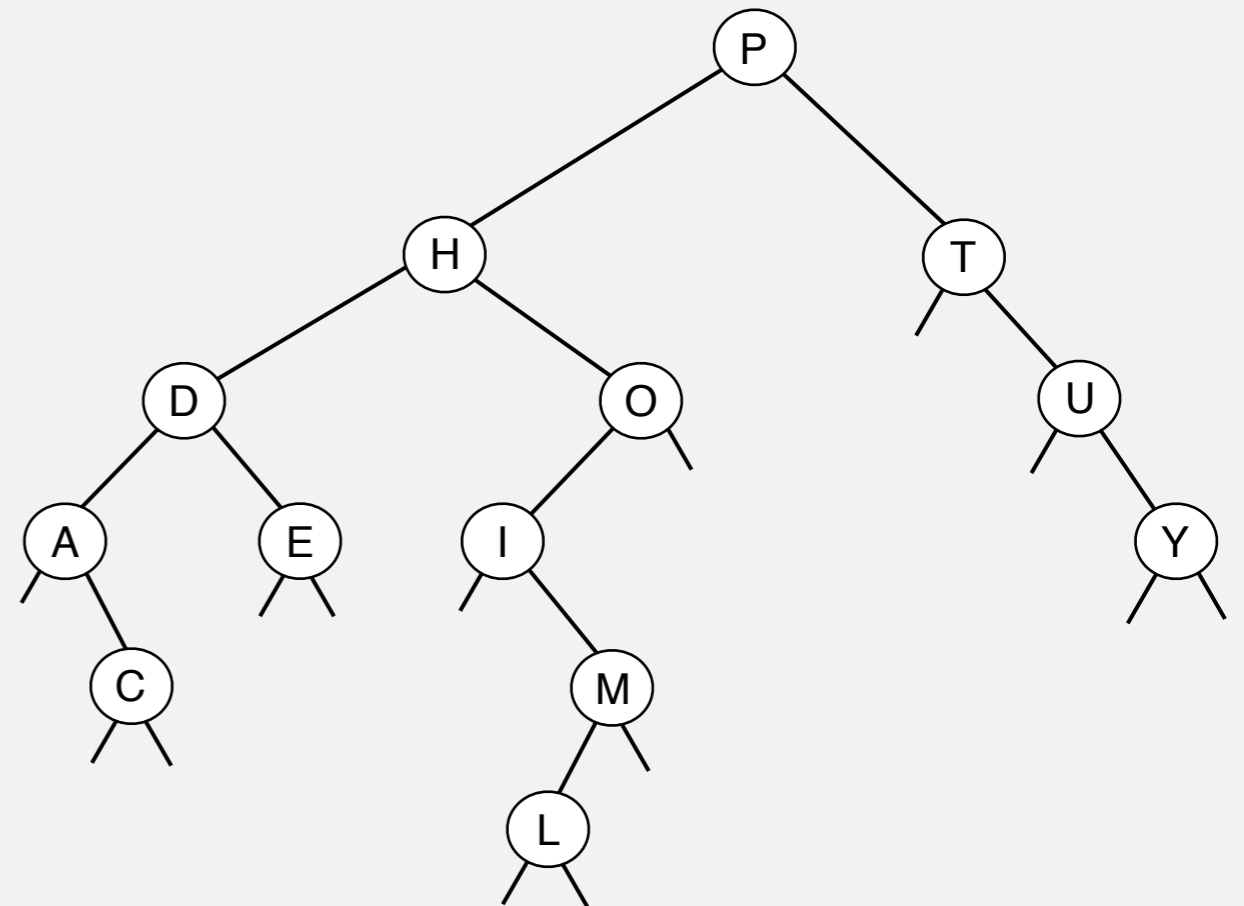

Remark. Correspondence is 1-1 if array has no duplicate keys.

BSTs: mathematical analysis

Proposition. If N distinct keys are inserted into a BST in **random** order, the expected number of compares for a search/insert is $O(\log N)$.

Pf. 1-1 correspondence with quicksort partitioning.

But... Worst-case height is N .

(exponentially small chance when keys are inserted in random order)

ST implementations: frequency counter

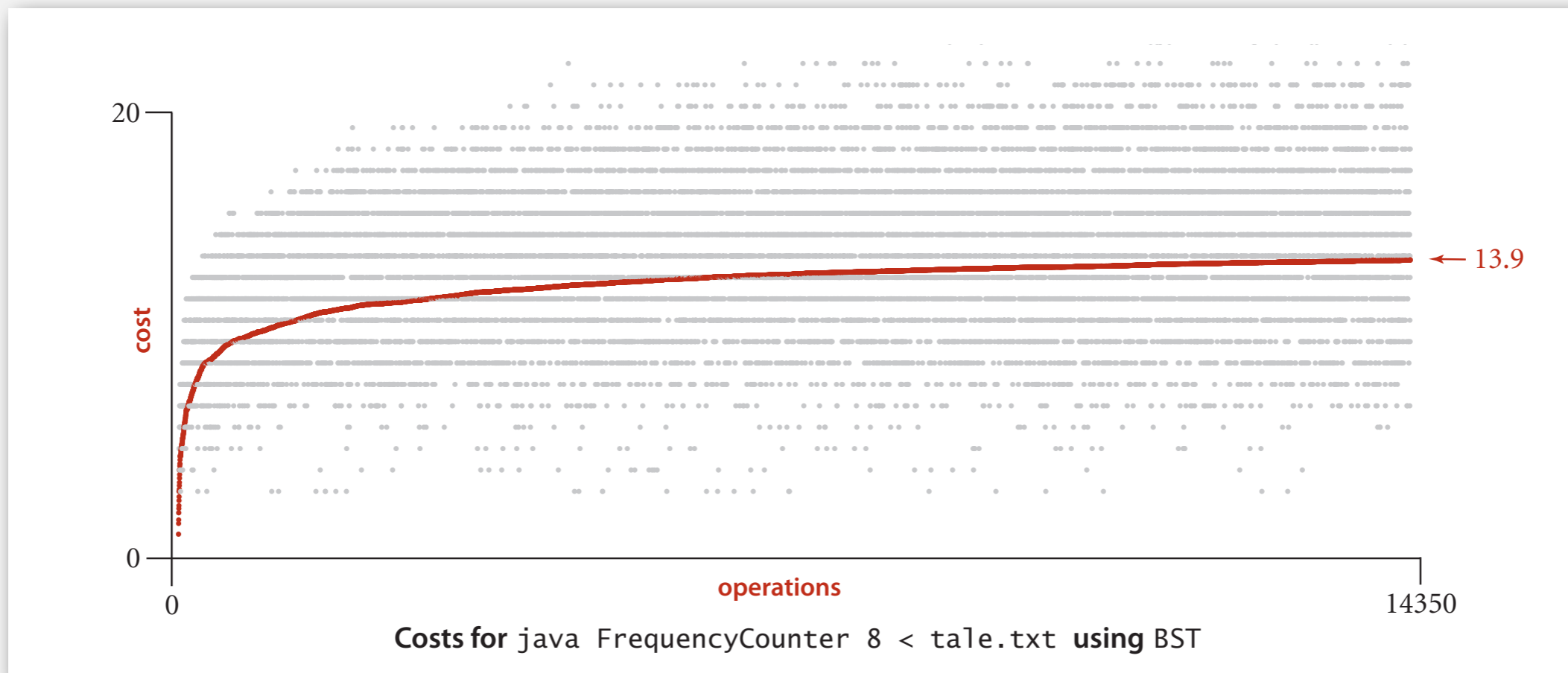
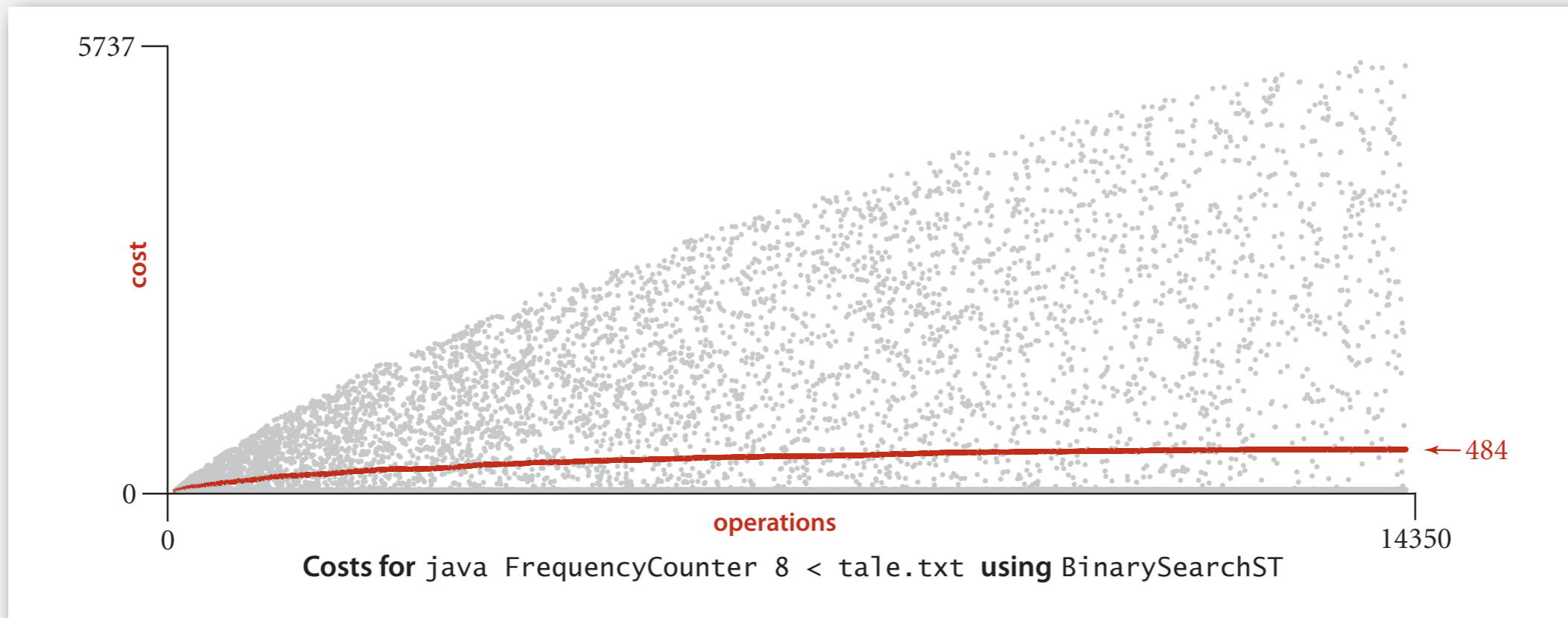

ST implementations: summary

implementation	guarantee		average case		ordered ops?	operations on keys
	search	insert	search hit	insert		
sequential search (unordered list)	N	N	N/2	N	no	equals ()
binary search (ordered array)	lg N	N	lg N	N/2	yes	compareTo ()
BST	N	N	lg N	lg N	<i>stay tuned</i>	compareTo ()

BINARY SEARCH TREES

- ▶ BSTs
- ▶ **Ordered operations**
- ▶ Deletion

Minimum and maximum

Minimum. Smallest key in table.

Maximum. Largest key in table.

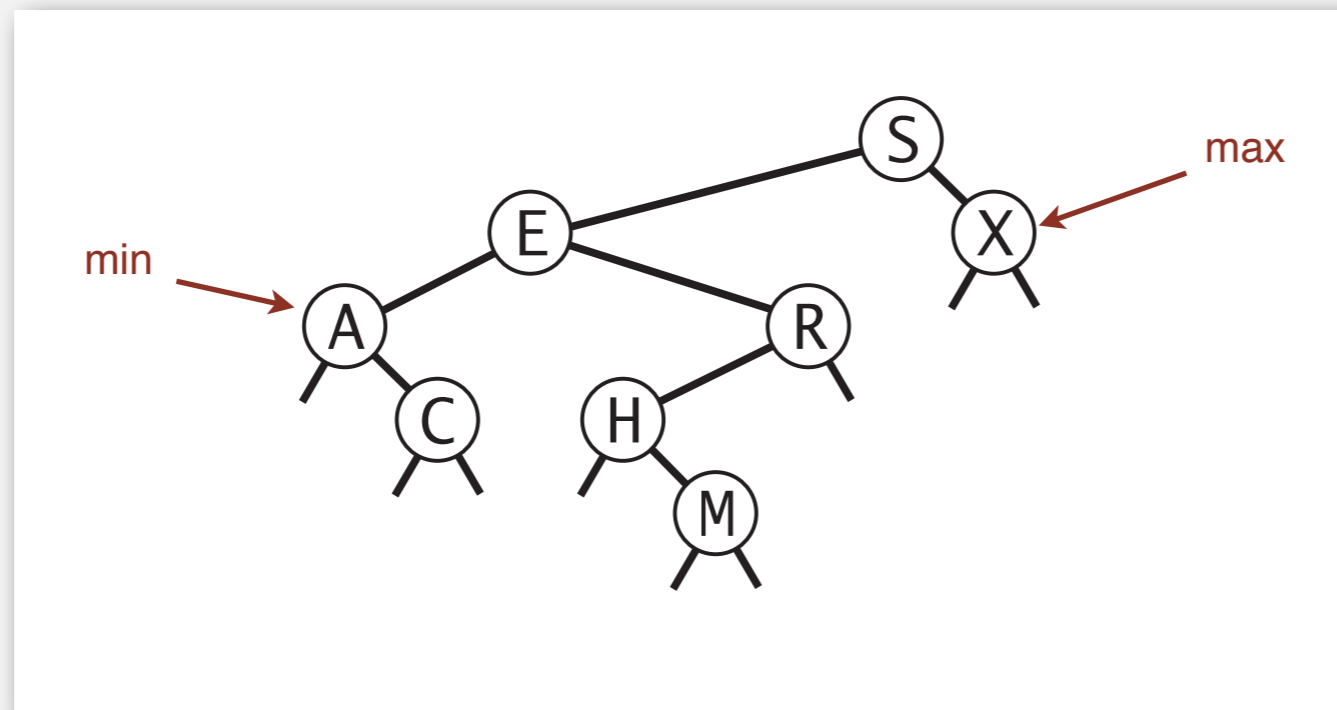

Q. How to find the min / max?

Floor and ceiling

Floor. Largest key \leq to a given key.

Ceiling. Smallest key \geq to a given key.

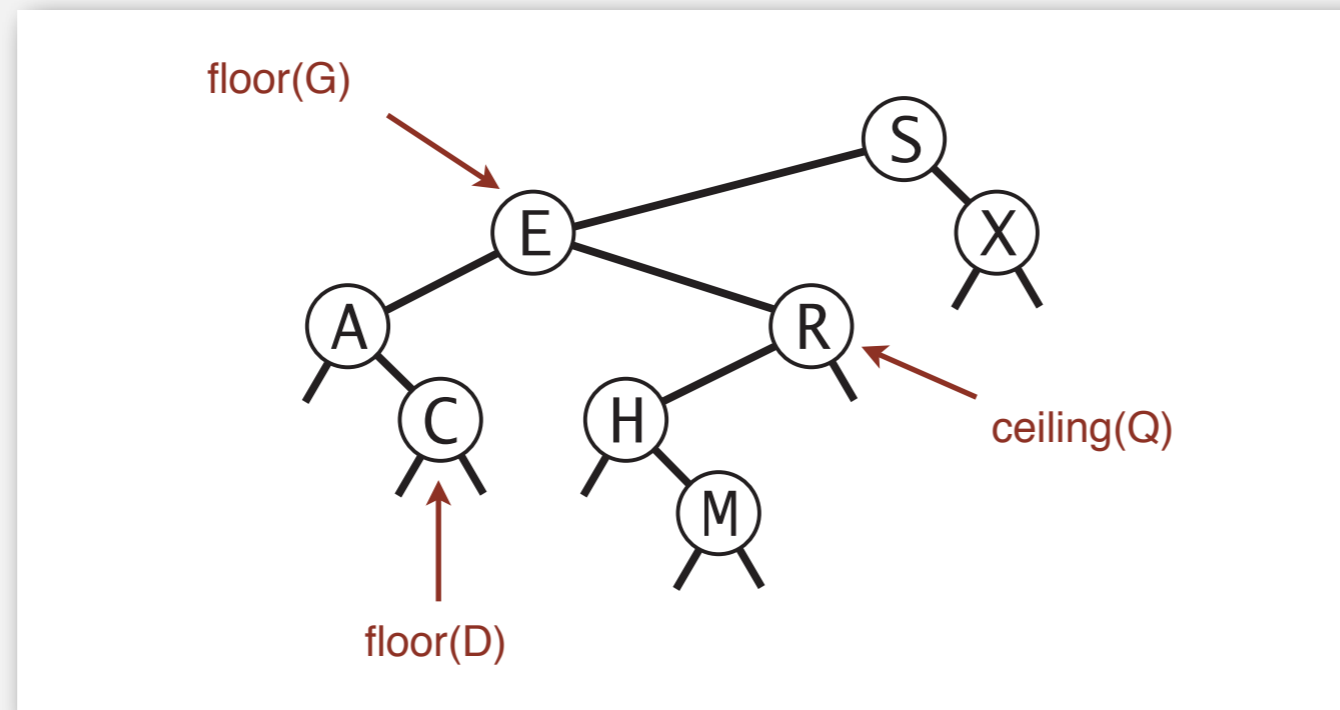

Q. How to find the floor /ceiling?

Computing the floor

Case 1. [k equals the key at root]

The floor of k is k .

Case 2. [k is less than the key at root]

The floor of k is in the left subtree.

Case 3. [k is greater than the key at root]

The floor of k is in the right subtree

(if there is **any** key $\leq k$ in right subtree);

otherwise it is the key in the root.

finding floor(G)

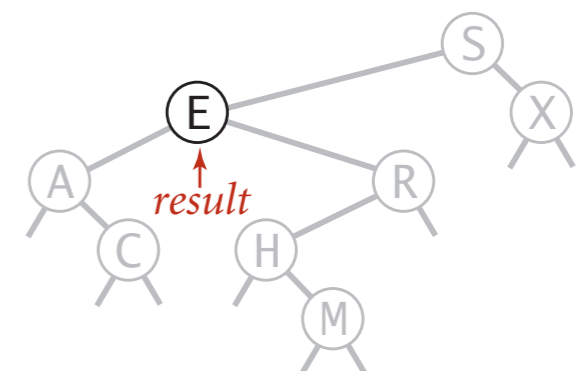
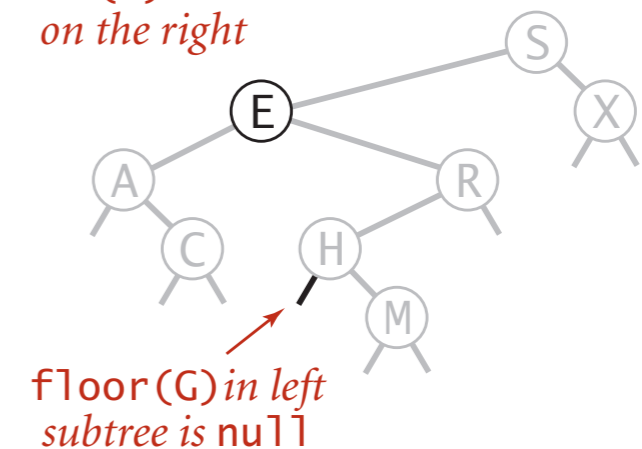
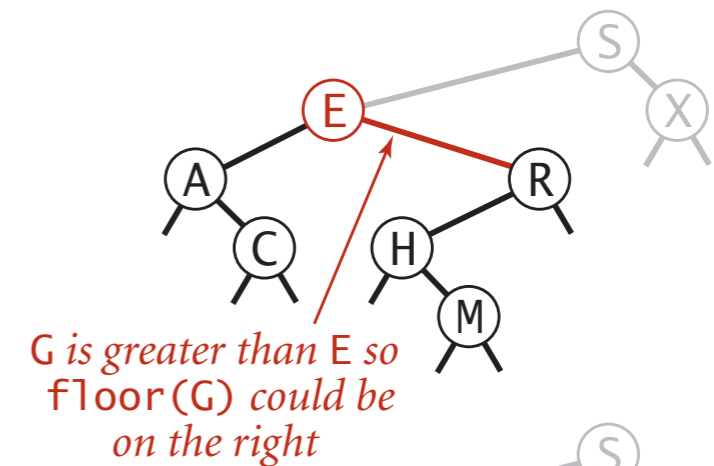
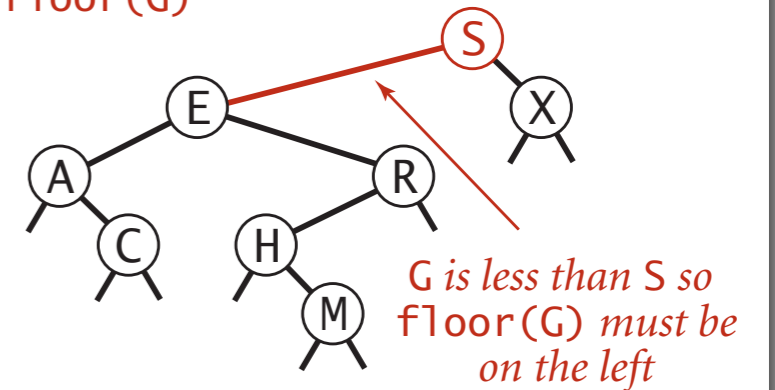

Computing the floor

```
public Key floor(Key key)
{
    Node x = floor(root, key);
    if (x == null) return null;
    return x.key;
}
private Node floor(Node x, Key key)
{
    if (x == null) return null;
    int cmp = key.compareTo(x.key);

    if (cmp == 0) return x;

    if (cmp < 0) return floor(x.left, key);

    Node t = floor(x.right, key);
    if (t != null) return t;
    else return x;
}
```

finding floor(G)

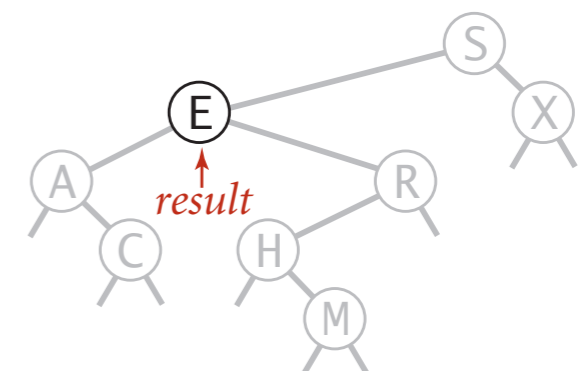
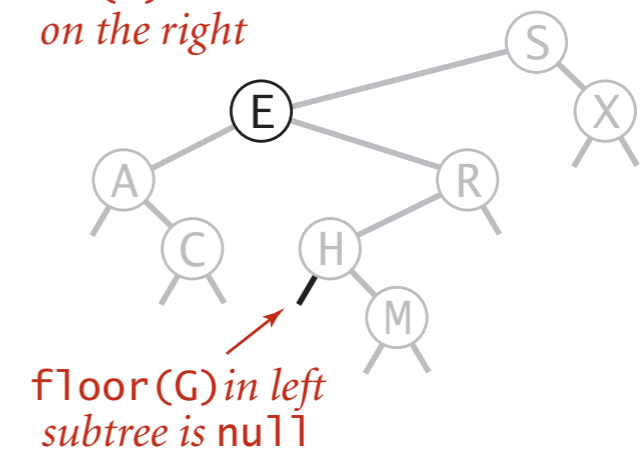
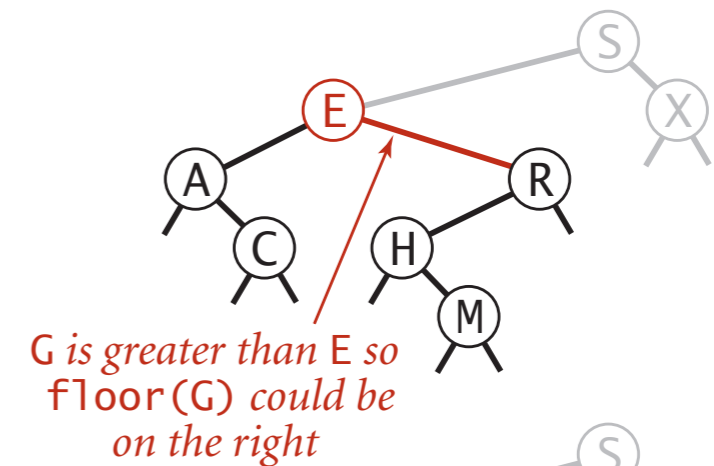
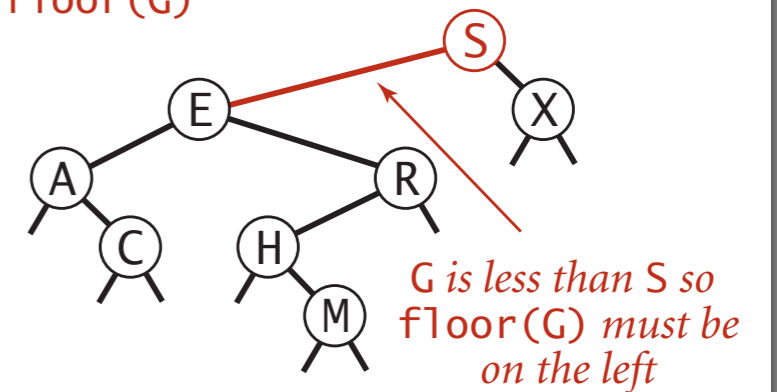

Subtree counts

In each node, we store the number of nodes in the subtree rooted at that node; to implement `size()`, return the count at the root.

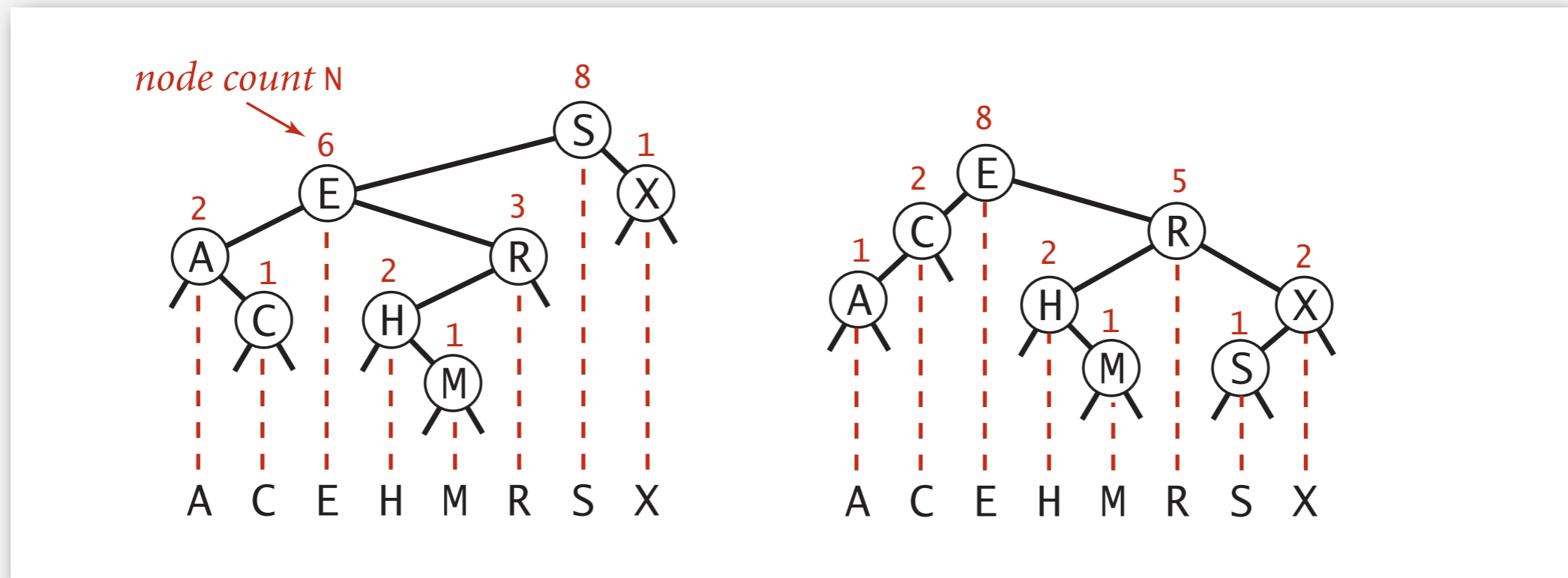

Remark. This facilitates efficient implementation of `rank()` and `select()`.

BST implementation: subtree counts

```
private class Node
{
    private Key key;
    private Value val;
    private Node left;
    private Node right;
    private int N;
}
```

number of nodes
in subtree

```
public int size()
{ return size(root); }
```

```
private int size(Node x)
{
    if (x == null) return 0;
    return x.N;
}
```

ok to call when
x is null

```
private Node put(Node x, Key key, Value val)
{
    if (x == null) return new Node(key, val);
    int cmp = key.compareTo(x.key);
    if (cmp < 0) x.left = put(x.left, key, val);
    else if (cmp > 0) x.right = put(x.right, key, val);
    else if (cmp == 0) x.val = val;
    x.N = 1 + size(x.left) + size(x.right);
    return x;
}
```

Rank

Rank. How many keys $< k$?

Easy recursive algorithm (4 cases!)

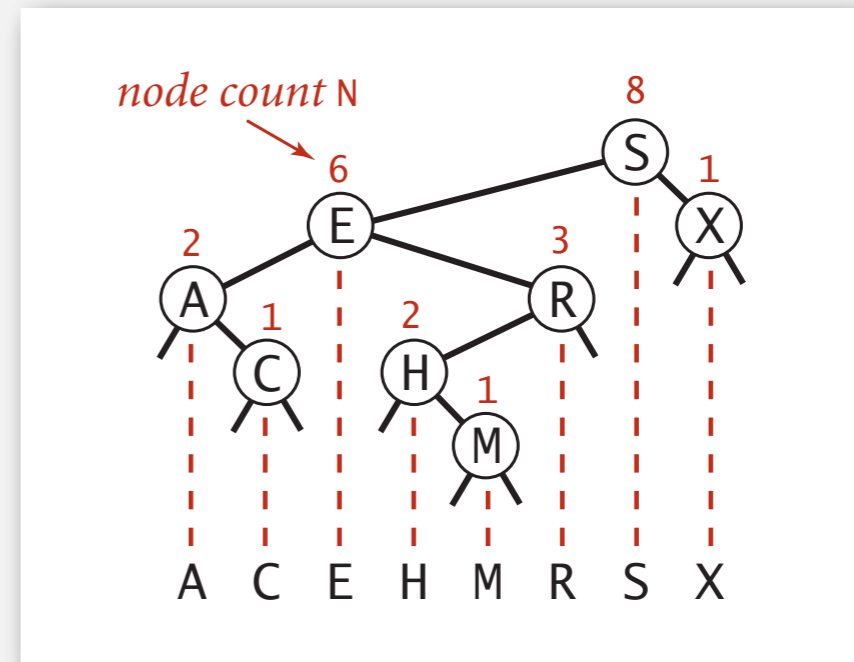

```
public int rank(Key key)
{ return rank(key, root); }

private int rank(Key key, Node x)
{
    if (x == null) return 0;
    int cmp = key.compareTo(x.key);
    if (cmp < 0) return rank(key, x.left);
    else if (cmp > 0) return 1 + size(x.left) + rank(key, x.right);
    else if (cmp == 0) return size(x.left);
}
```

Selection

Select. Key of given rank.

```
public Key select(int k)
{
    if (k < 0) return null;
    if (k >= size()) return null;
    Node x = select(root, k);
    return x.key;
}

private Node select(Node x, int k)
{
    if (x == null) return null;
    int t = size(x.left);
    if (t > k)
        return select(x.left, k);
    else if (t < k)
        return select(x.right, k-t-1);
    else if (t == k)
        return x;
}
```

finding select(3)
the key of rank 3

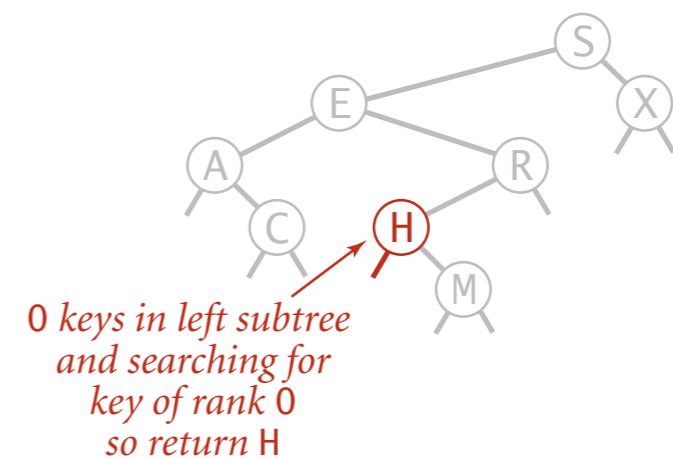
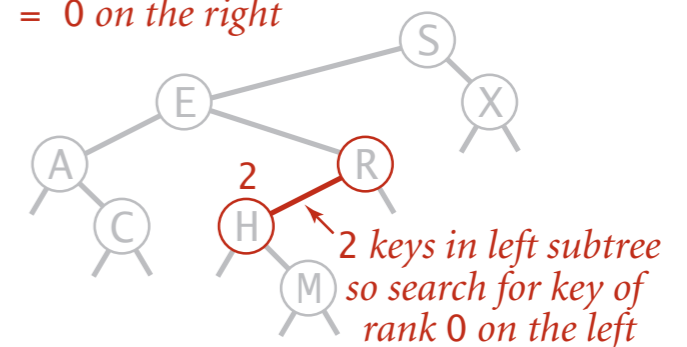
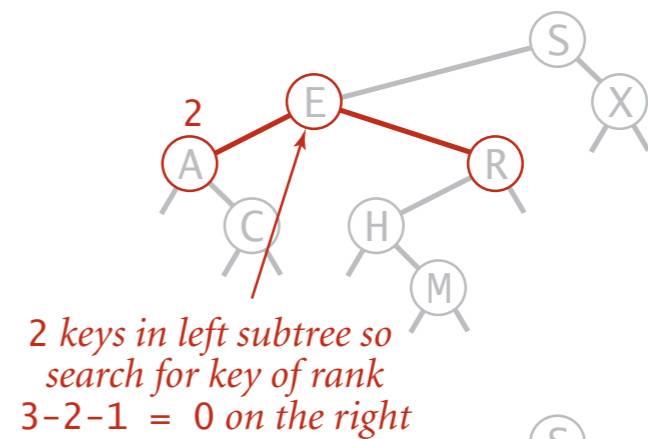
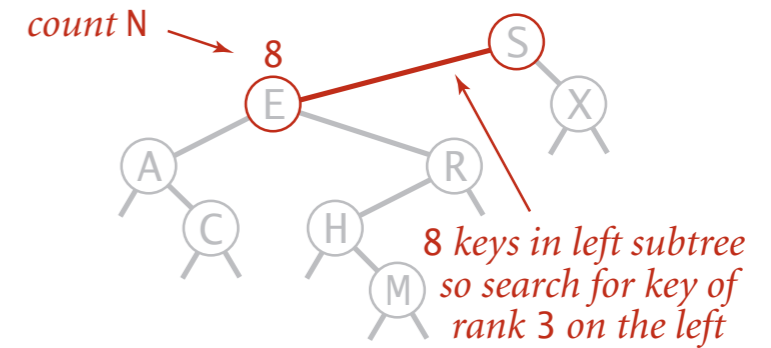

Inorder traversal

- Traverse left subtree.
- Enqueue key.
- Traverse right subtree.

```
public Iterable<Key> keys()  
{  
    Queue<Key> q = new Queue<Key>();  
    inorder(root, q);  
    return q;  
}  
  
private void inorder(Node x, Queue<Key> q)  
{  
    if (x == null) return;  
    inorder(x.left, q);  
    q.enqueue(x.key);  
    inorder(x.right, q);  
}
```

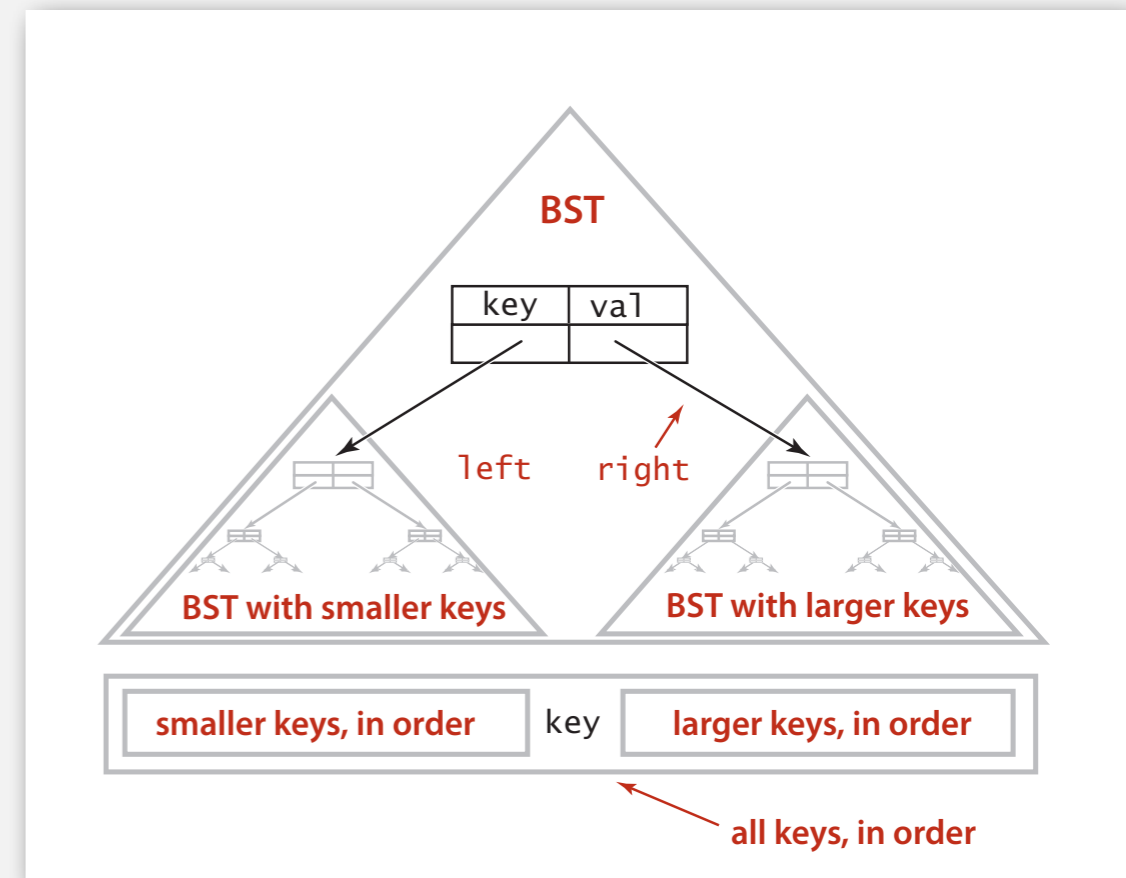

Property. Inorder traversal of a BST yields keys in ascending order.

Inorder traversal

- Traverse left subtree.
- Enqueue key.
- Traverse right subtree.

```
inorder(S)
  inorder(E)
    inorder(A)
      enqueue A
    inorder(C)
      enqueue C
    enqueue E
  inorder(R)
    inorder(H)
      enqueue H
    inorder(M)
      enqueue M
    enqueue R
  enqueue S
inorder(X)
  enqueue X
```

recursive calls

```
A
C
E
H
M
R
S
X
```

queue

```
S
S E
S E A
S E A C
S E R
S E R H
S E R H M
S X
```

function call stack

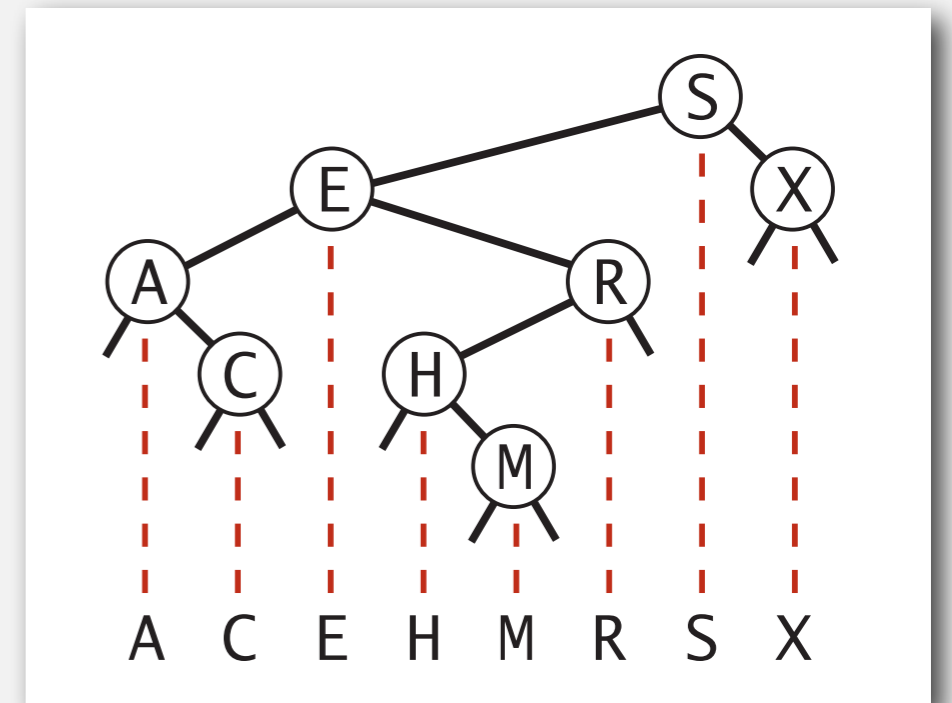

BST: ordered symbol table operations summary

	sequential search	binary search	BST
search	N	$\lg N$	h
insert	1	N	h
min / max	N	1	h
floor / ceiling	N	$\lg N$	h
rank	N	$\lg N$	h
select	N	1	h
ordered iteration	$N \log N$	N	N

h = height of BST
(proportional to $\log N$
if keys inserted in random order)

order of growth of running time of ordered symbol table operations

BINARY SEARCH TREES

- ▶ BSTs
- ▶ Ordered operations
- ▶ **Deletion**

ST implementations: summary

implementation	guarantee			average case			ordered iteration?	operations on keys
	search	insert	delete	search hit	insert	delete		
sequential search (linked list)	N	N	N	N/2	N	N/2	no	<code>equals()</code>
binary search (ordered array)	lg N	N	N	lg N	N/2	N/2	yes	<code>compareTo()</code>
BST	N	N	N	lg N	lg N	???	yes	<code>compareTo()</code>

Next. Deletion in BSTs.

BST deletion: lazy approach

To remove a node with a given key:

- Set its value to `null`.
- Leave key in tree to guide searches (but don't consider it equal to search key).

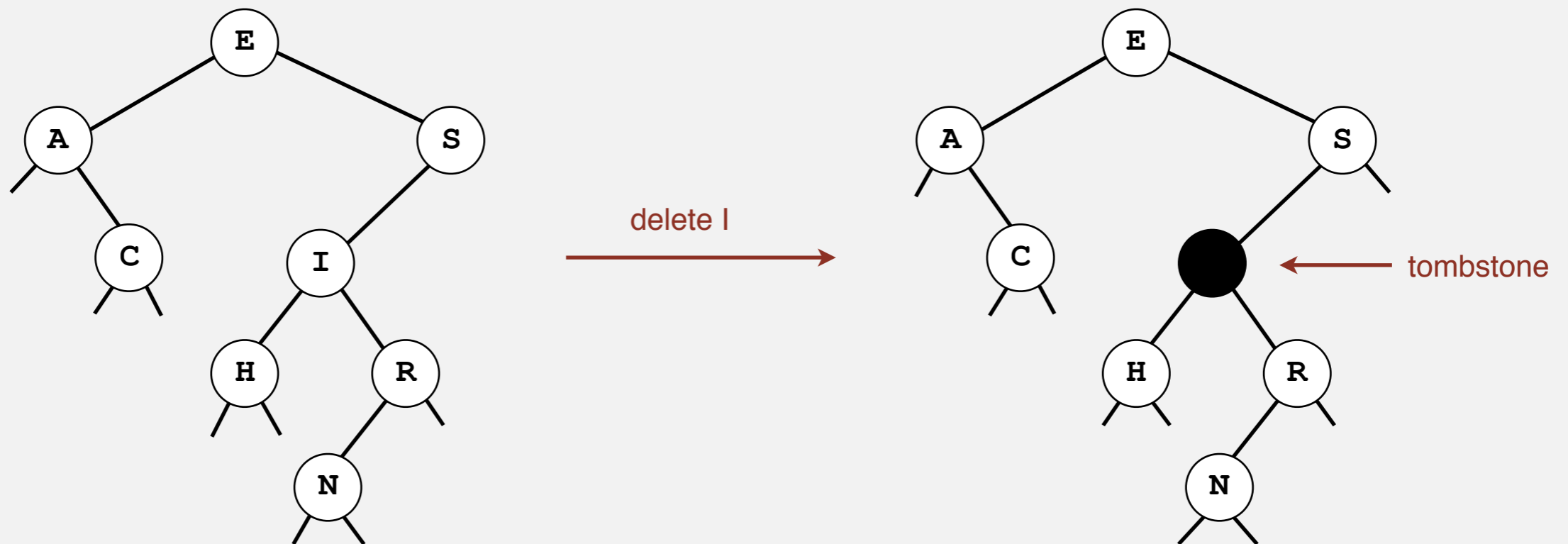

Cost. $O(\log N')$ per insert, search, and delete (if keys in random order), where N' is the number of key-value pairs ever inserted in the BST.

Unsatisfactory solution. Tombstone (memory) overload.

Deleting the minimum

To delete the minimum key:

- Go left until finding a node with a null left link.
- Replace that node by its right link.
- Update subtree counts.

```
public void deleteMin()  
{ root = deleteMin(root); }  
  
private Node deleteMin(Node x)  
{  
    if (x.left == null) return x.right;  
    x.left = deleteMin(x.left);  
    x.N = 1 + size(x.left) + size(x.right);  
    return x;  
}
```

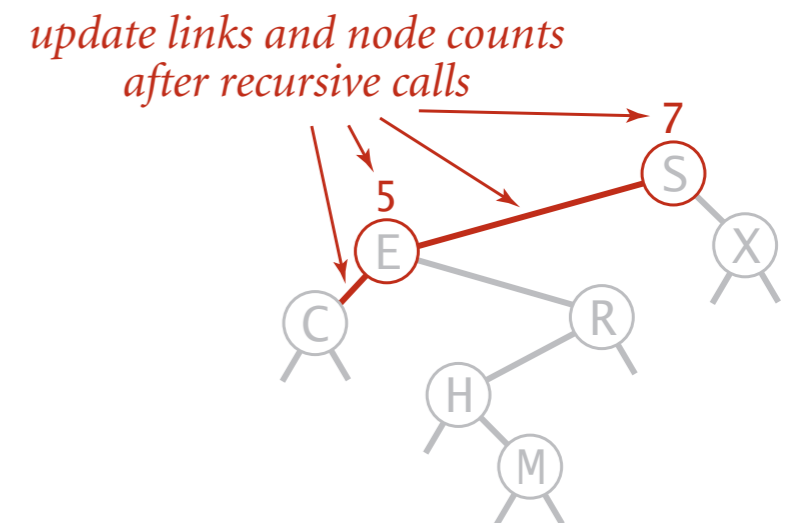
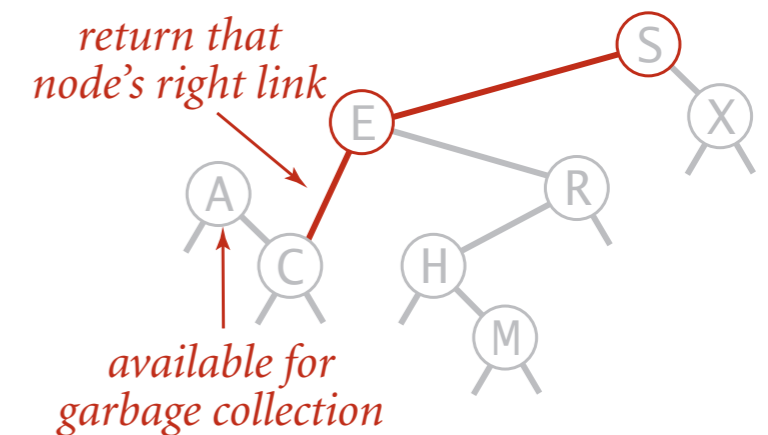
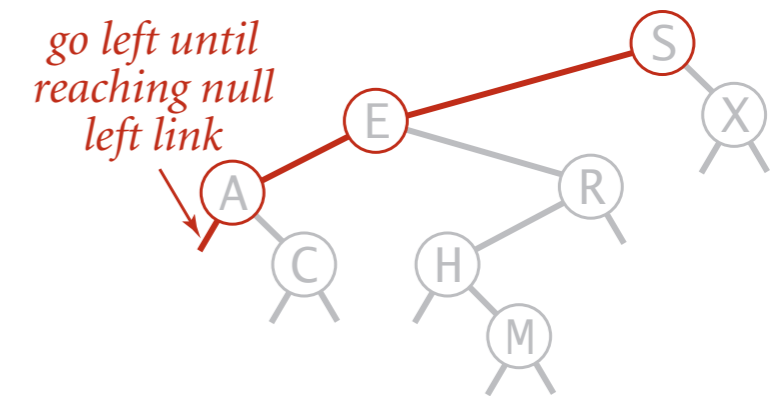

Hibbard deletion

To delete a node with key k : search for node t containing key k .

Case 0. [0 children] Delete t by setting parent link to null.

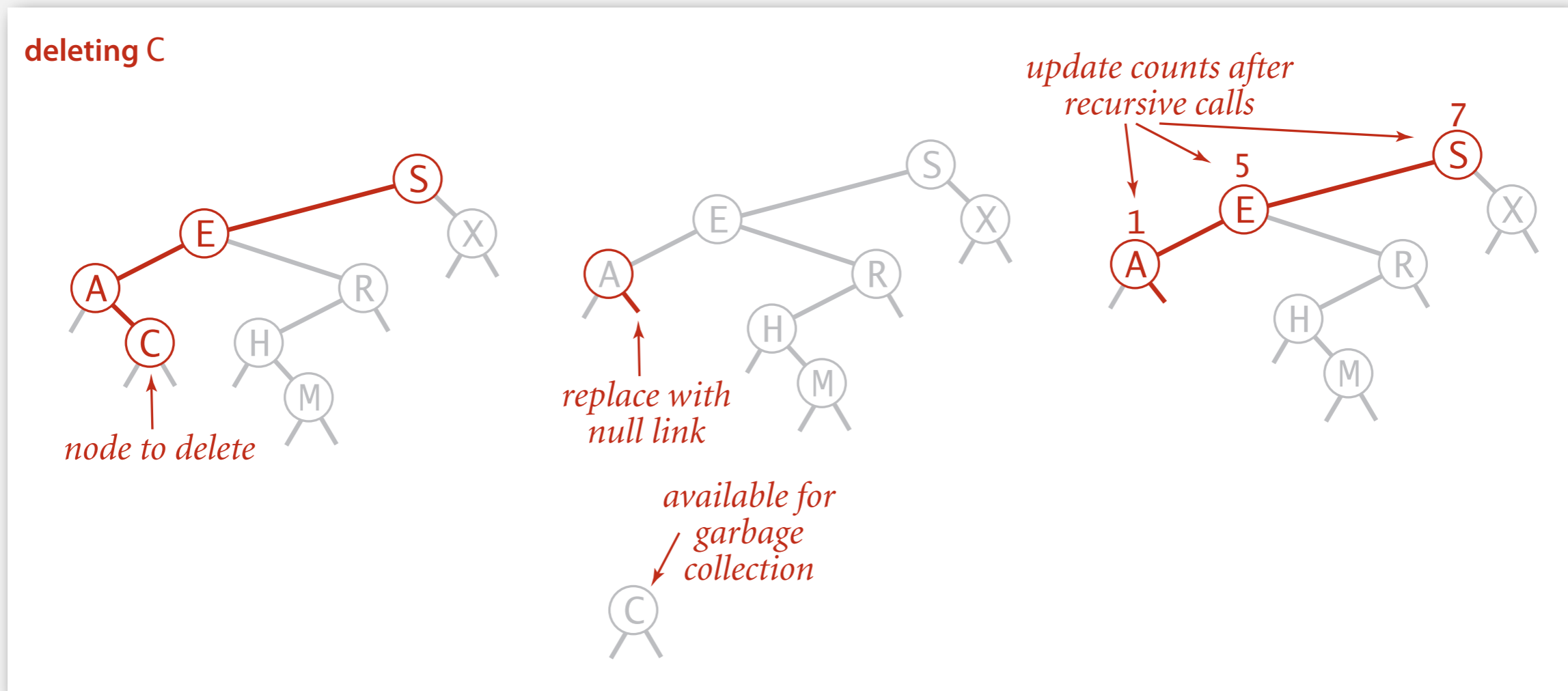

Hibbard deletion

To delete a node with key k : search for node t containing key k .

Case I. [1 child] Delete t by replacing parent link.

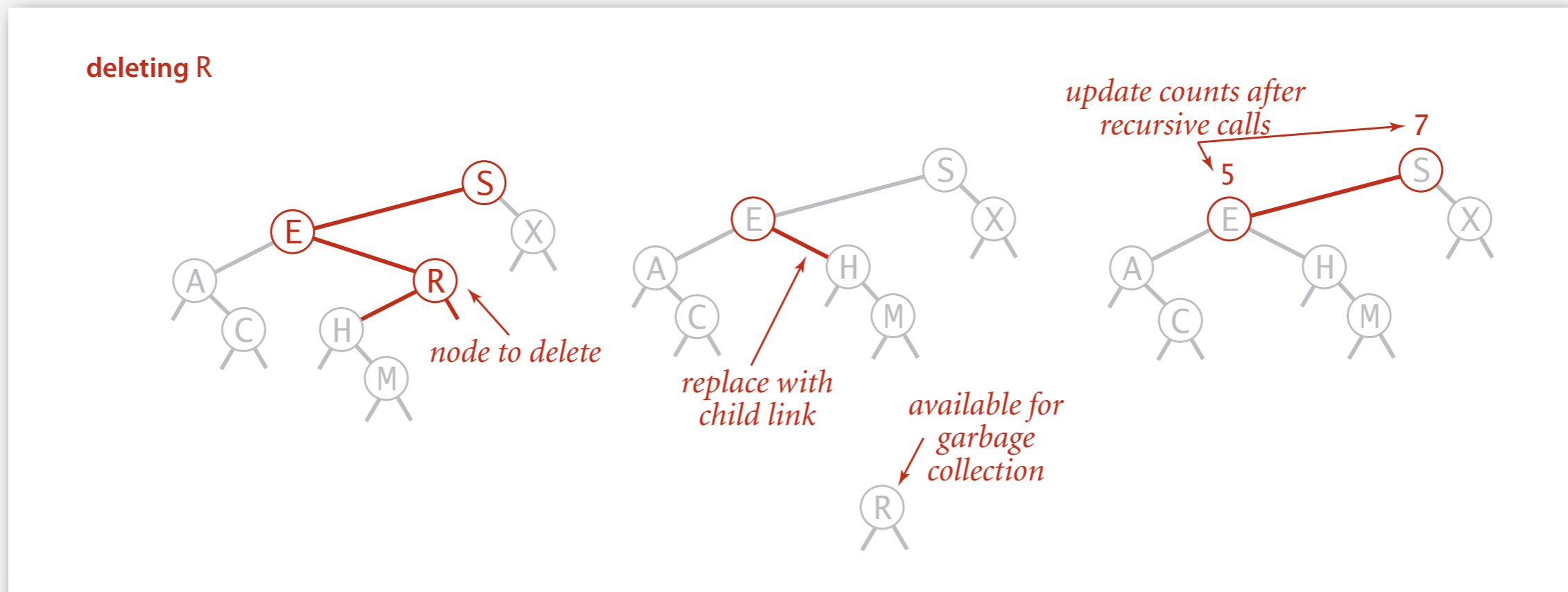

Hibbard deletion

To delete a node with key k : search for node t containing key k .

Case 2. [2 children]

- Find successor x of t .
- Delete the minimum in t 's right subtree.
- Put x in t 's spot.

- ← x has no left child
- ← but don't garbage collect x
- ← still a BST

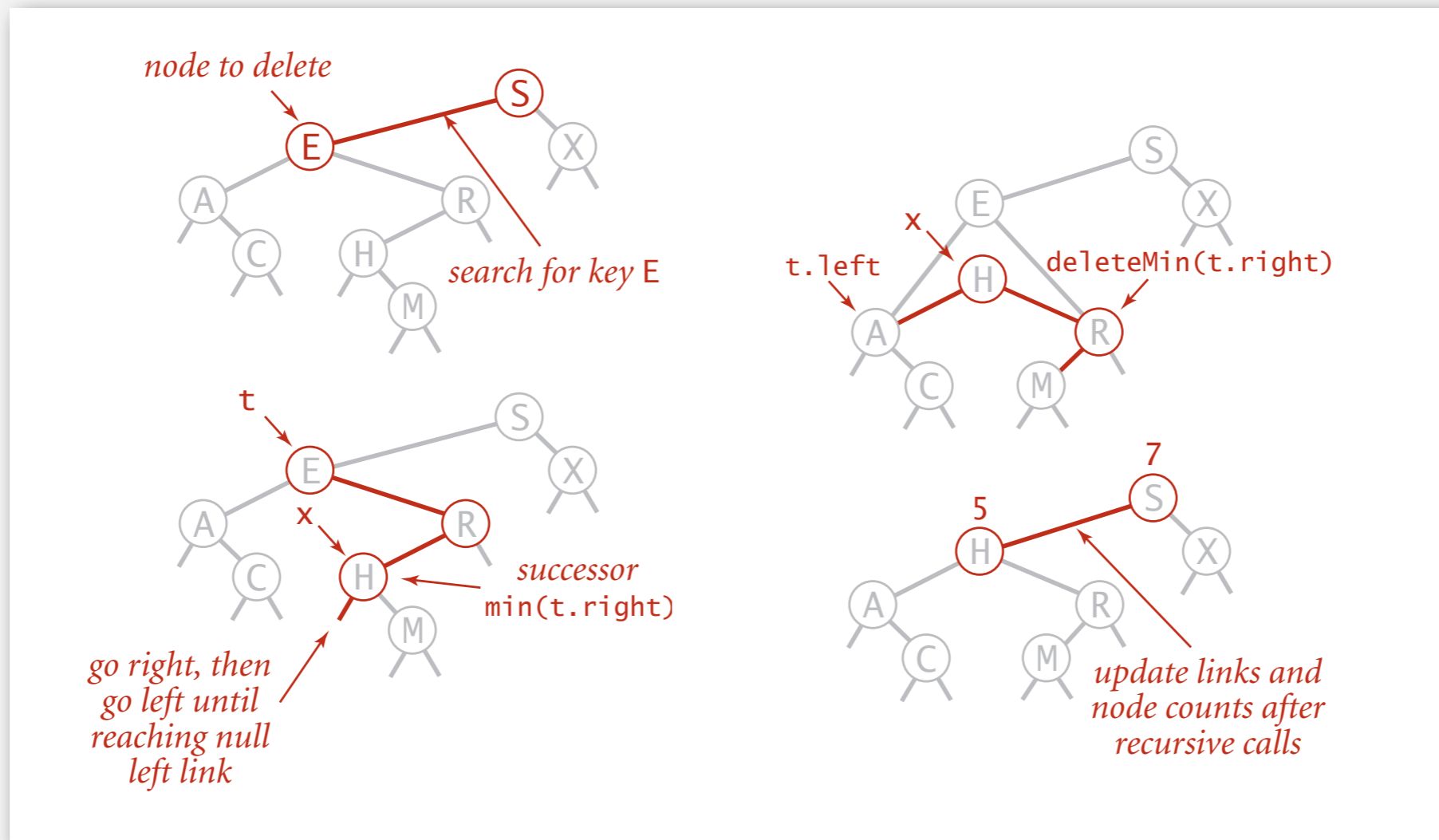

Hibbard deletion: Java implementation

```
public void delete(Key key)
{  root = delete(root, key);  }

private Node delete(Node x, Key key) {
    if (x == null) return null;
    int cmp = key.compareTo(x.key);
    if      (cmp < 0) x.left  = delete(x.left,  key);
    else if (cmp > 0) x.right = delete(x.right, key);
    else {
        if (x.right == null) return x.left;

        Node t = x;
        x = min(t.right);
        x.right = deleteMin(t.right);
        x.left = t.left;
    }
    x.N = size(x.left) + size(x.right) + 1;
    return x;
}
```

← search for key

← no right child

← replace with successor

← update subtree counts

Hibbard deletion: analysis

Unsatisfactory solution. Not symmetric.

If we always delete from the same side, the shape of tree will be not random, the right subtrees are trimmed!

$N = 150$
max = 16
avg = 9.3
opt = 6.4

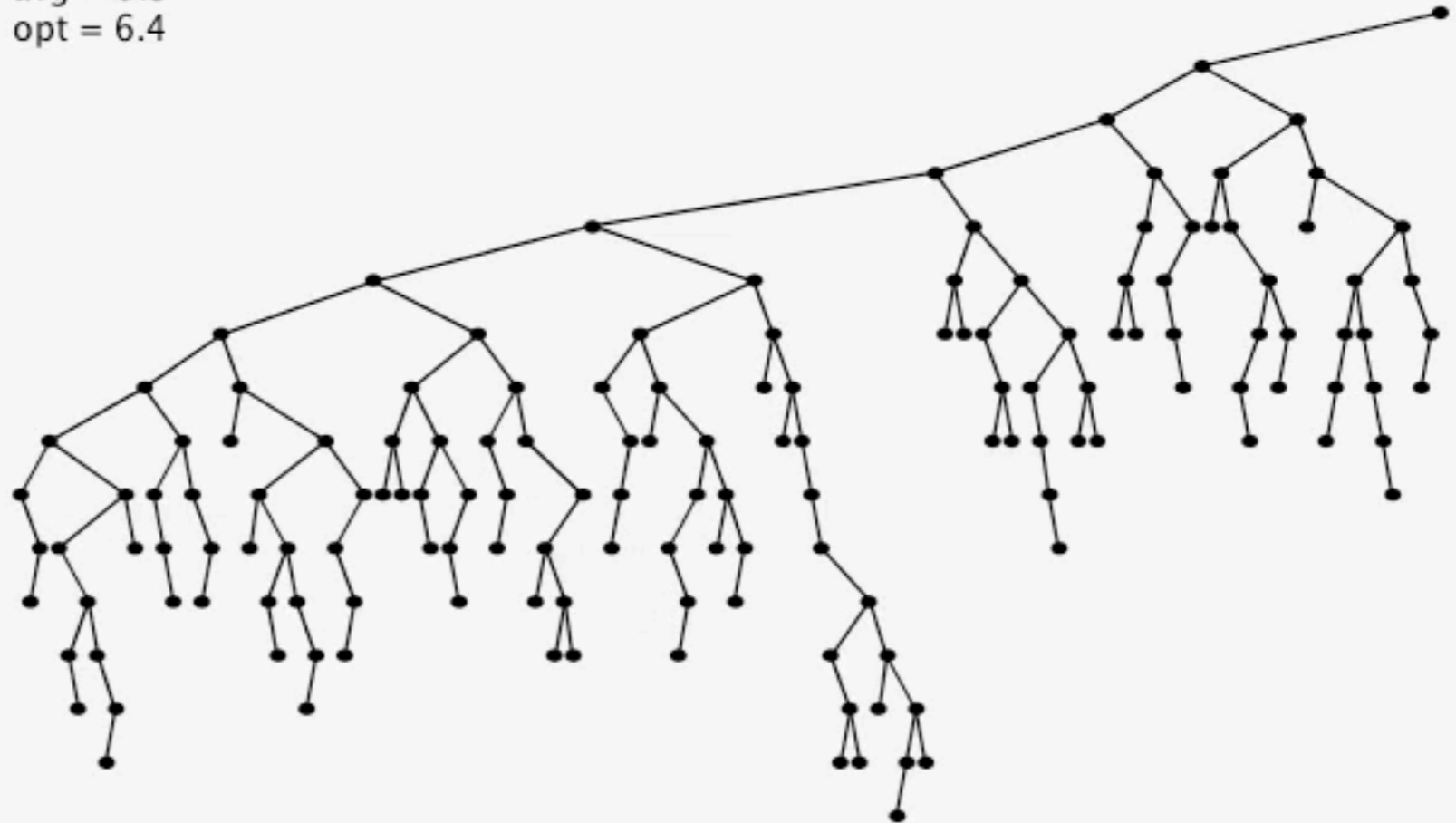

Surprising consequence. Trees not random (!) \Rightarrow \sqrt{N} per op.

Longstanding open problem. Simple and efficient delete for BSTs.

ST implementations: summary

implementation	guarantee			average case			ordered iteration?	operations on keys
	search	insert	delete	search hit	insert	delete		
sequential search (linked list)	N	N	N	$N/2$	N	$N/2$	no	<code>equals()</code>
binary search (ordered array)	$\lg N$	N	N	$\lg N$	$N/2$	$N/2$	yes	<code>compareTo()</code>
BST	N	N	N	$\lg N$	$\lg N$	\sqrt{N}	yes	<code>compareTo()</code>

other operations also become \sqrt{N}
if deletions allowed

Red-black BST. Guarantee logarithmic performance for all operations.