

CMP784

DEEP LEARNING

Lecture #12 – Self-Supervised Learning



HACETTEPE
UNIVERSITY
COMPUTER
VISION LAB

Erkut Erdem // Hacettepe University // Fall 2023

Previously on CMP784

- Motivation for Variational Autoencoders (VAEs)
- Mechanics of VAEs
- Separability of VAEs
- Training of VAEs
- Evaluating representations
- Vector Quantized Variational Autoencoders (VQ-VAEs)

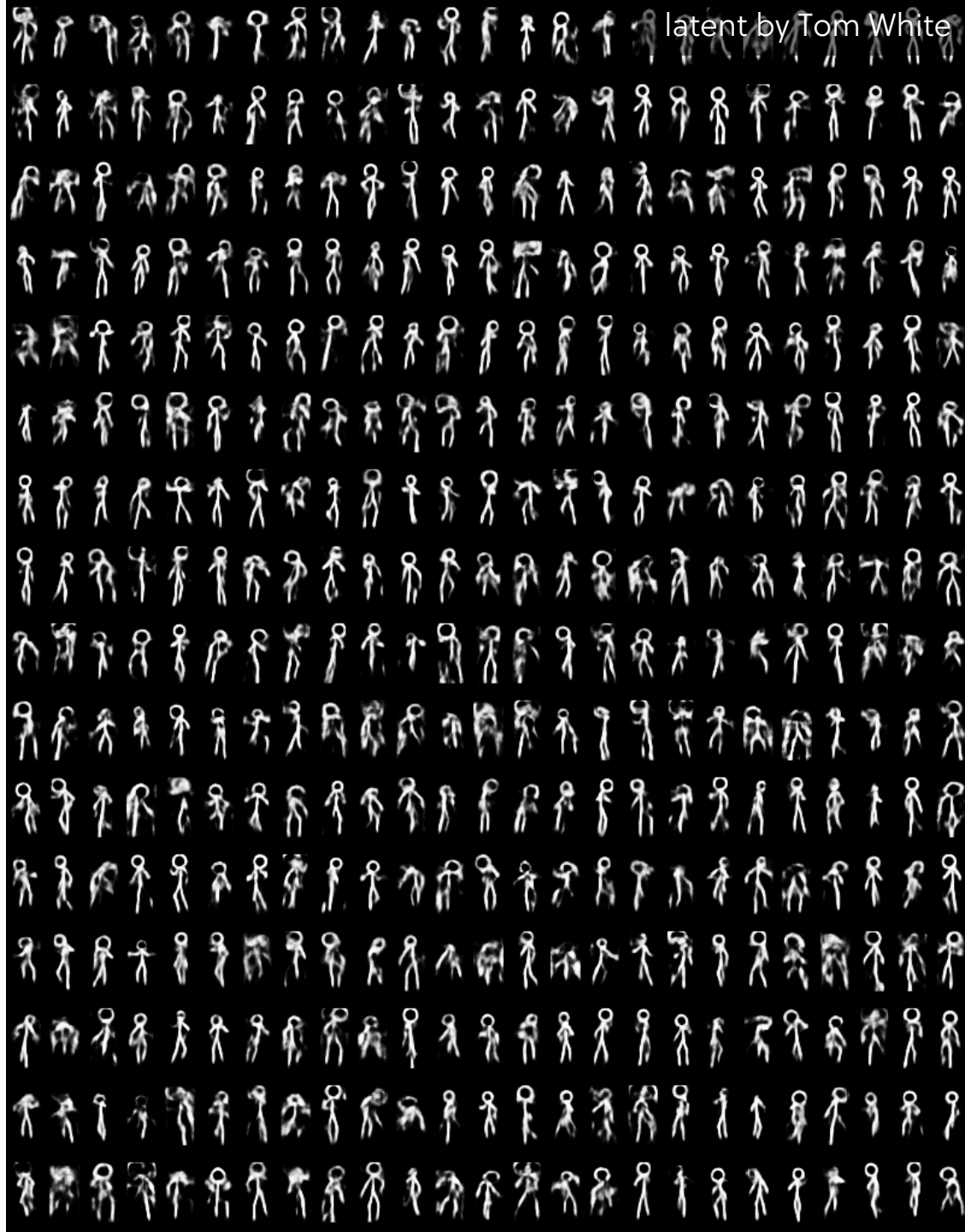

Lecture Overview

- Predictive / Self-supervised learning
- Self-supervised learning in NLP
- Self-supervised learning in vision
- Multimodal Self-supervised learning

Disclaimer: Much of the material and slides for this lecture were borrowed from

- Andrej Risteski's CMU 10707 class
- Jimmy Ba's UToronto CSC413/2516 class
- Fei-Fei Li, Ranjay Krishna, Danfei Xu's CS231n class
- Justin Johnson's EECS 498/598 class

Supervised vs Unsupervised Learning

Supervised Learning

Data: (x, y)

x is data, y is label

Goal: Learn a function to map $x \rightarrow y$

Examples: Classification, regression, object detection, semantic segmentation, image captioning, sentiment analysis, etc.

Unsupervised Learning

Data: x

Just data, no labels!

Goal: Learn some underlying hidden structure of the data

Examples: Clustering, dimensionality reduction, feature learning, density estimation, etc.

Unsupervised Learning

- Learning from data **without** labels.
- What can we hope to do:
 - **Task A:** Fit a parametrized **structure** (e.g. clustering, low-dimensional subspace, manifold) to data to reveal something meaningful about data (**Structure learning**)
 - **Task B:** Learn a (parametrized) **distribution** close to data generating distribution. (**Distribution learning**)
 - **Task C:** Learn a (parametrized) distribution that implicitly reveals an **“embedding”/“representation”** of data for downstream tasks. (**Representation/feature learning**)
- Entangled! The “structure” and “distribution” often reveals an embedding.

Supervised Learning

- Supervised learning is not how we learn!

Babies don't get supervision for everything they see!



Solution: Self-Supervised Learning

- Lets build methods that learn from "raw" data – no annotations required
- **Unsupervised Learning:** Model isn't told what to predict. Older terminology, not used as much today.
- **Self-Supervised Learning:** Model is trained to predict some naturally-occurring signal in the raw data rather than human annotations.

Solution: Self-Supervised Learning

- Lets build methods that learn from "raw" data – no annotations required
- **Unsupervised Learning:** Model isn't told what to predict. Older terminology, not used as much today.
- **Self-Supervised Learning:** Model is trained to predict some naturally-occurring signal in the raw data rather than human annotations.
- **Semi-Supervised Learning:** Train jointly with some labeled data and (a lot) of unlabeled data.

Self-Supervised Learning

- Given **unlabeled** data, **design supervised tasks** that induce a good representation for downstream tasks.
- No good mathematical formalization, but the intuition is to “force” the predictor used in the task to learn something “**semantically meaningful**” about the data.

Self-Supervised Learning: Pretext then Transfer

Step 1: Pretrain a network on a pretext task that doesn't require supervision



Input Image: x

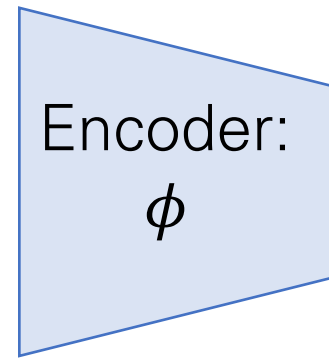

Features: $\phi(x)$

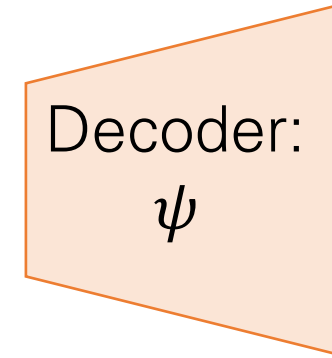

Prediction: \hat{y}



Loss:
 $L(\hat{y}, y)$

Self-Supervised Learning: Pretext then Transfer

Step 1: Pretrain a network on a pretext task that doesn't require supervision



Input Image: x

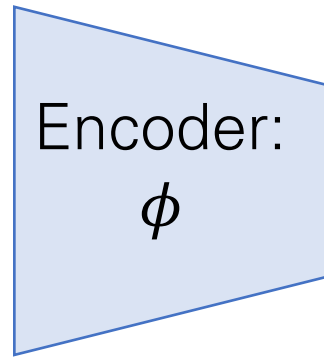

Features: $\phi(x)$

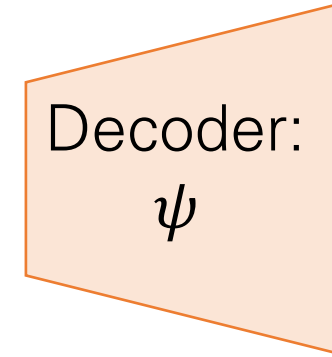

Prediction: \hat{y}



Loss:
 $L(\hat{y}, y)$

Step 2: Transfer encoder to downstream tasks via linear classifiers, KNN, finetuning



Input Image: x

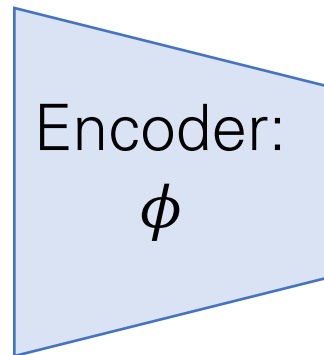

Features: $\phi(x)$



Downstream tasks:
Image classification,
object detection, semantic
segmentation

Self-Supervised Learning: Pretext then Transfer

Generative: Predict part of the input signal

- Autoencoders (sparse, denoising, masked)
- Autoregressive
- GANs
- Colorization
- Inpainting

Discriminative: Predict something about the input signal

- Context prediction
- Rotation
- Clustering
- Contrastive

Multimodal: Use some additional signal in addition to RGB images

- Video
- 3D
- Sound
- Language

Self-Supervised Learning

- ▶ Predict any part of the input from any other part.
- ▶ Predict the **future** from the **past**.
- ▶ Predict the **future** from the **recent past**.
- ▶ Predict the **past** from the **present**.
- ▶ Predict the **top** from the **bottom**.
- ▶ Predict the occluded from the visible
- ▶ **Pretend there is a part of the input you don't know and predict that.**

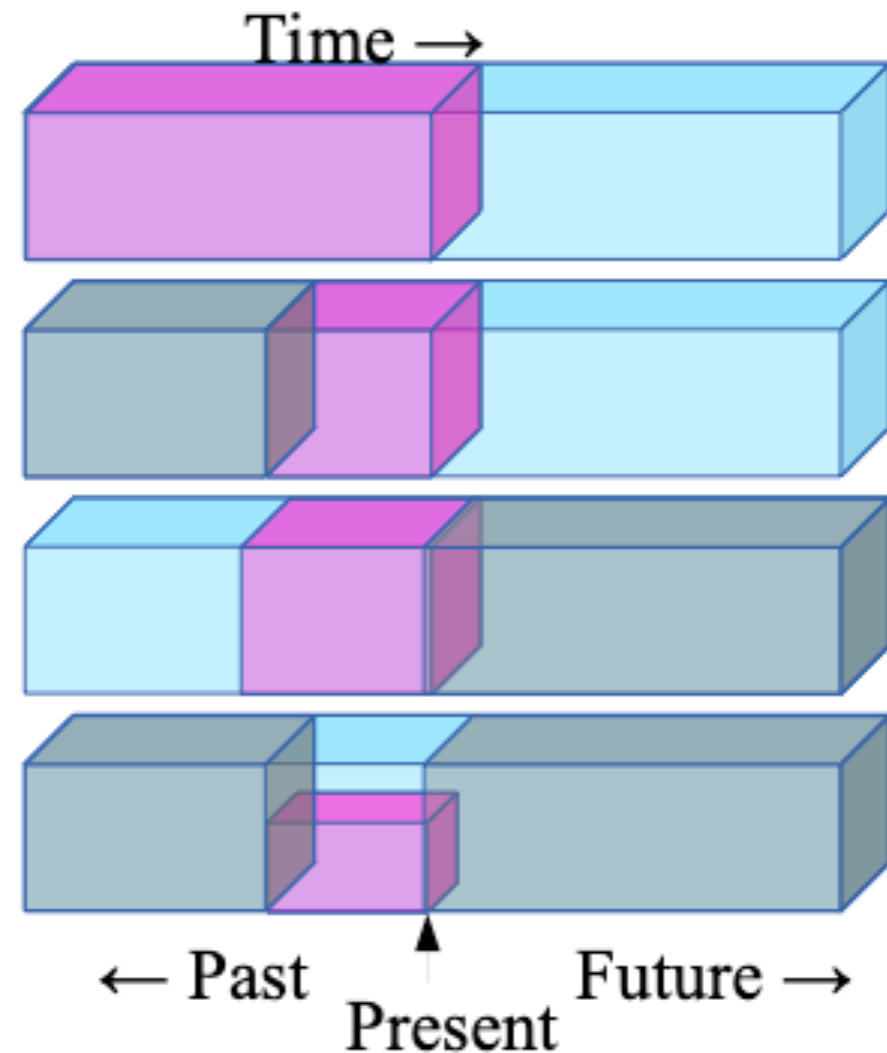

Self-Supervised Learning in NLP

Word Embeddings

- **Semantically** meaningful vector representations of words

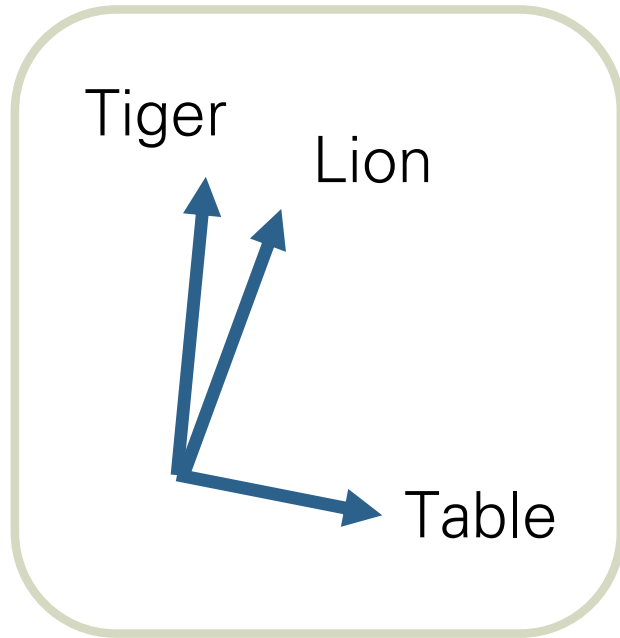

Example: Inner product (possibly scaled, i.e. cosine similarity) correlates with word similarity.

Word Embeddings

- **Semantically** meaningful vector representations of words

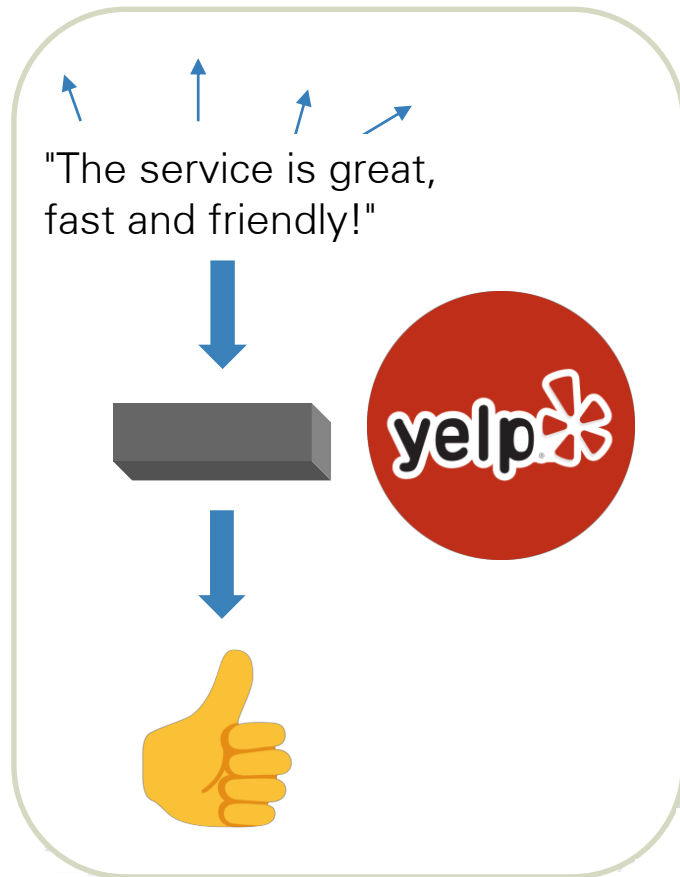

Example: Can use embeddings to do sentiment classification by training a simple (e.g. linear) classifier

Word Embeddings

- **Semantically** meaningful vector representations of words



Example: Can train a “simple” network that if fed word embeddings for two languages, can effectively translate.

Word Embeddings via Predictive Learning

- **Basic task:** predict the next word, given a few previous ones.



In other words, optimize for

$$\max_{\theta} \sum_t \log p_{\theta} (x_t | x_{t-1}, x_{t-2}, \dots, x_{t-L})$$

Word Embeddings via Predictive Learning

- **Basic task:** predict the next word, given a few previous ones.

$$\max_{\theta} \sum_t \log p_{\theta} (x_t | x_{t-1}, x_{t-2}, \dots, x_{t-L})$$

Inspired by classical assumptions in NLP that the underlying distribution is Markov – that is, x_t only depends on the previous few words.

(Of course, this is violated if you wish to model long texts like paragraphs / books.)

The main issue: The trivial way of parametrizing $p_{\theta} (x_t | x_{t-1}, x_{t-2}, \dots, x_{t-L})$ is a “lookup table” with V^L entries.

Word Embeddings via Predictive Learning

- **Basic task:** predict the next word, given a few previous ones.

$$\max_{\theta} \sum_t \log p_{\theta}(x_t | x_{t-1}, x_{t-2}, \dots, x_{t-L})$$

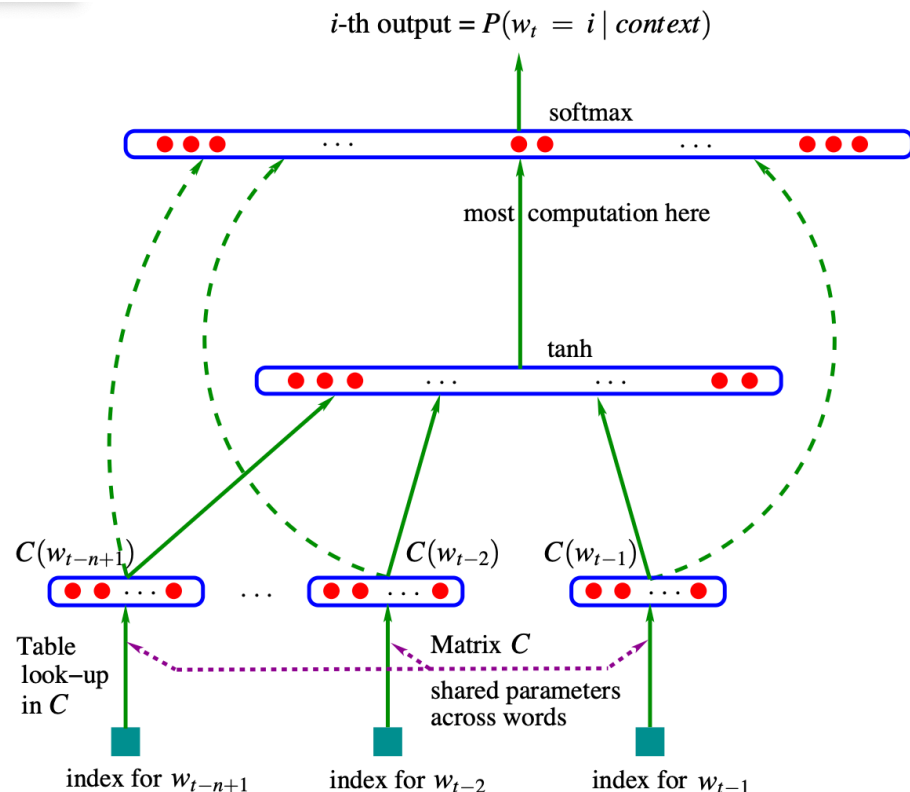

[Bengio-Ducharme-Vincent-Janvin '2003]: A neural parametrization of the above probabilities.

Main ingredients:

- Embeddings: A word embedding $C(w)$ for all words w in dictionary.
- Non-linear transforms: Potentially deep network taking as inputs i , $C(x_{t-1})$, $C(x_{t-2})$, ..., $C(x_{t-L})$, and outputting some vector o . Can be recurrent net too.
- Softmax: Softmax distribution for x_t with parameters given by o .

Word Embeddings via Predictive Learning

- **Related:** predict middle word in a sentence, given surrounding ones.

$$\max_{\theta} \sum_t \log p_{\theta} (x_t | x_{t-L}, \dots, x_{t-1}, x_{t+1}, \dots, x_{t+L})$$

CBOW (Continuous Bag of Words): proposed by Mikolov et al. '13

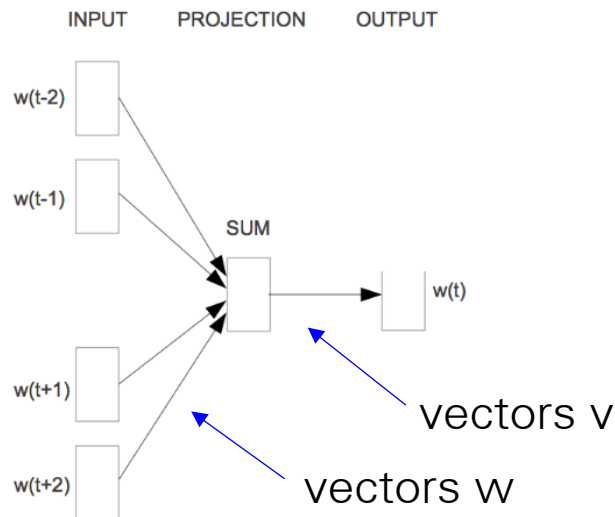

Parametrization is chosen s.t.

$$p_{\theta} (x_t | x_{t-L}, \dots, x_{t-1}, x_{t+1}, \dots, x_{t+L}) \propto \exp \left(v_{x_t}, \sum_{i=t-L}^{t+L} w_{t_i} \right)$$

Word Embeddings via Predictive Learning

- **Related:** predict middle word in a sentence, given surrounding ones.

$$\max_{\theta} \sum_t \sum_{i=t-L, i \neq t}^{t+L} \log p_{\theta}(x_i | x_t)$$

Skip-Gram: also proposed by Mikolov et al. '13

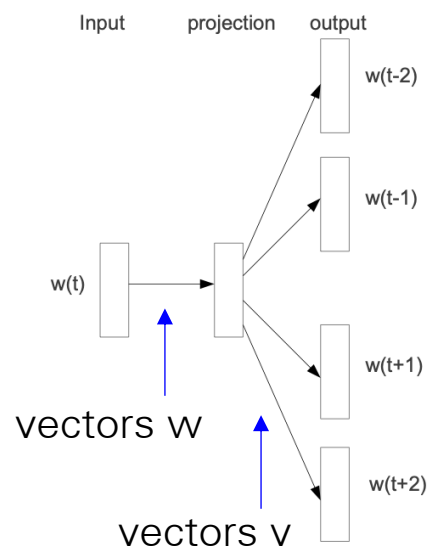

Parametrization is chosen s.t. $p_{\theta}(x_i | x_t) \propto \exp(v_{x_i}, w_{x_t})$

In practice, lots of other tricks are tacked on to deal with the slowest part of training: the softmax distribution (partition function sums over entire vocabulary).

Common ones are negative sampling, hierarchical softmax, etc.

Word Embeddings via Predictive Learning

- **Related:** predict middle word in a sentence, given surrounding ones.

$$\max_{\theta} \sum_t \sum_{i=t-L, i \neq t}^{t+L} \log p_{\theta}(x_i | x_t)$$

Skip-Gram: also proposed by Mikolov et al. '13

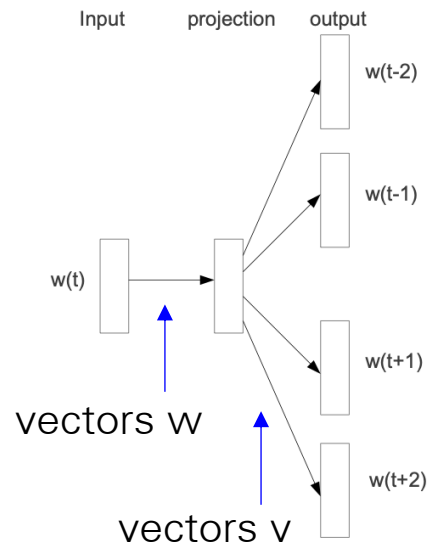

Tomas Mikolov

10/7/13



There are quite a few differences between the skip-gram and the CBOW models. However, if you have a lot of training data, their performance should be comparable.

If you want to see a list of advantages of each model, then my current experience is:

Skip-gram: works well with small amount of the training data, represents well even rare words or phrases

CBOW: several times faster to train than the skip-gram, slightly better accuracy for the frequent words

This can get even a bit more complicated if you consider that there are two different ways how to train the models: the normalized hierarchical softmax, and the un-normalized negative sampling. Both work quite differently.

Overall, the best practice is to try few experiments and see what works the best for you, as different applications have different requirements.

- show quoted text -

Evaluating Word Embeddings

- First variant (predict next word, given previous ones) can be used as a **generative model** for text. (Also called **language model**.) The other ones cannot.

- In former case, a natural measure is the **cross-entropy**

$$-\mathbb{E}_{x_1, x_2, \dots, x_T} \log p_\theta (x_{\leq T}) = \mathbb{E}_{x_1, x_2, \dots, x_T} \sum_t \log p_\theta (x_t | x_{<t})$$

- For convenience, we often take exponential of this (called **perplexity**)
- If we do not have a generative model, we have to use **indirect** means.

Evaluating Word Embeddings

- **Intrinsic tasks:** Test performance of word embeddings on tasks measuring their “semantic” properties. Examples include solving “which is the most similar word” queries, analogy queries (i.e. “man is to woman as king is to ??”)
- **Extrinsic tasks:** How well can we “finetune” the word embeddings to solve some (supervised) downstream task. “Finetune” usually means train a (relatively small) feedforward network. Examples of such tasks include:
 - Part-of-Speech Tagging (determine whether a word is noun/verb/...),
 - Named Entity Recognition (recognizing named entities like persons, places) – e.g. label a sentence as Picasso[person] died in France[country], many others.

Semantic Similarity

- **Observation:** similar words tend to have larger (renormalized) inner products (also called cosine similarity).
- Precisely, if we look at the word embeddings for words i, j
 $\left\langle \frac{w_i}{\|w_i\|}, \frac{w_j}{\|w_j\|} \right\rangle = \cos(w_i, w_j)$ tends to be larger for similar words i, j
Example: the nearest neighbors to “Frog” look like

0. frog
1. frogs
2. toad
3. litoria
4. leptodactylidae
5. rana
6. lizard
7. eleutherodactylus



3. litoria



4. leptodactylidae



5. rana



7. eleutherodactylus

- To solve semantic similarity query like “which is the most similar word to”, output the word with the highest cosine similarity.

Semantic Clustering

- Consequence: clustering word embeddings should give “semantically” relevant clusters.

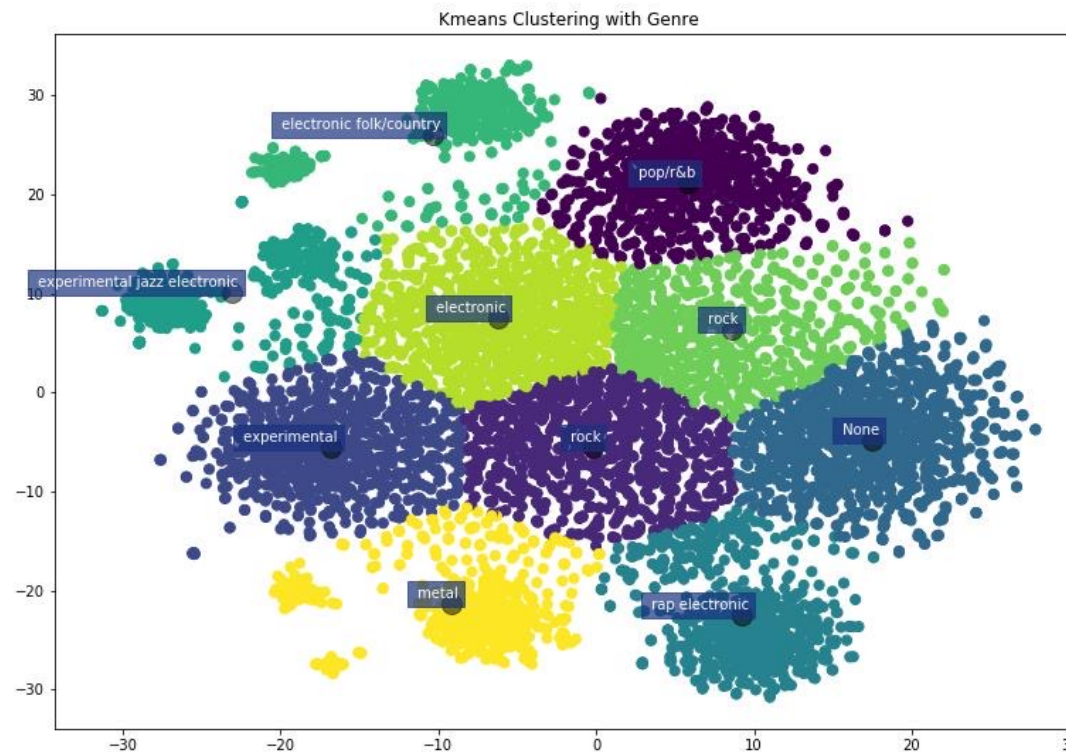

t-SNE projection of word embeddings for artists (clustered by genre). Image from <https://medium.com/free-code-camp/learn-tensorflow-the-word2vec-model-and-the-tsne-algorithm-using-rock-bands-97c99b5dcb3a>

Analogies

- Observation: You can solve analogy queries by linear algebra.

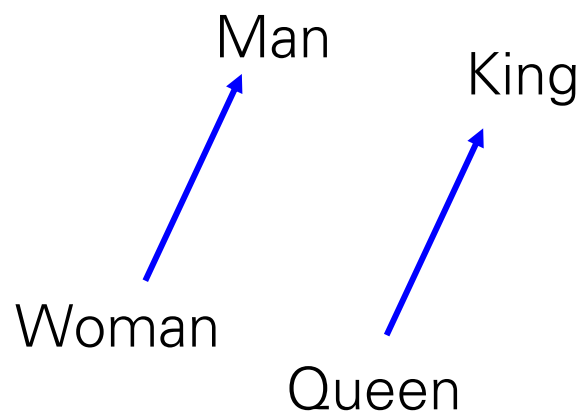

Precisely, $w = \text{queen}$ will be the solution to:

$$\operatorname{argmin}_w \|v_w - v_{\text{king}} - (v_{\text{woman}} - v_{\text{man}})\|^2$$

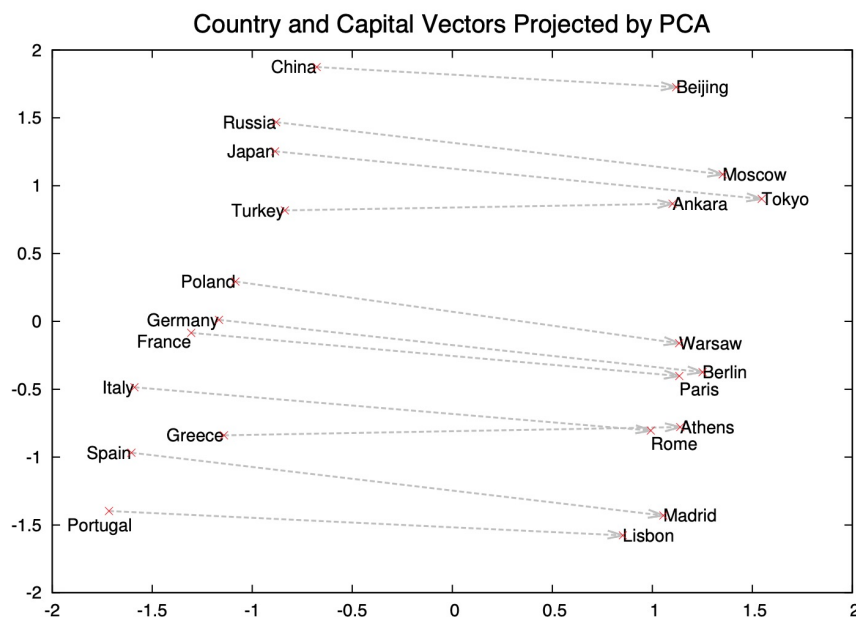

Figure 2: Two-dimensional PCA projection of the 1000-dimensional Skip-gram vectors of countries and their capital cities. The figure illustrates ability of the model to automatically organize concepts and learn implicitly the relationships between them, as during the training we did not provide any supervised information about what a capital city means.

Language Models (LMs)

- A statistical model that assigns probabilities to the words in a sentences.
- **Most commonly:** Given previous words, what should the next one be?
- **Neural language model:** Model the probability of words given others using neural networks.

Recurrent Architectures for LM

- We can use recurrent architectures.
- LSTM, GRU ...
- Great for variable length inputs, like sentences.

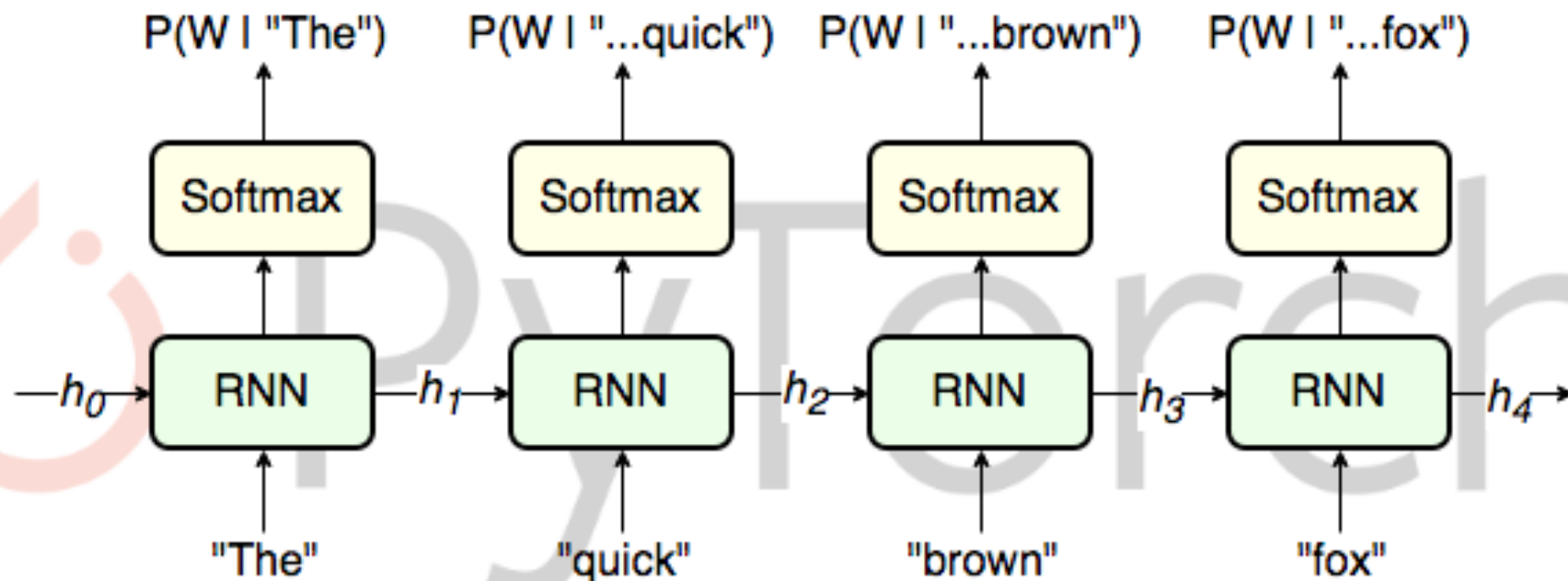

Recurrent Architectures for LM

- What are some of the problems with recurrent architectures?
 - Not parallelizable across instances.
 - Cannot model long dependences.
 - Optimization difficulties (vanishing gradients).

- Attention to the rescue!

Transformers

Properties of the transformer architecture:

- Fully feed forward.
- Equivariance properties of scaled dot product attention (important):
 - How does the output change if we permute the order of queries? (equivariance)
 - How does the output change if we permute the key-value pairs in unison? (invariance)

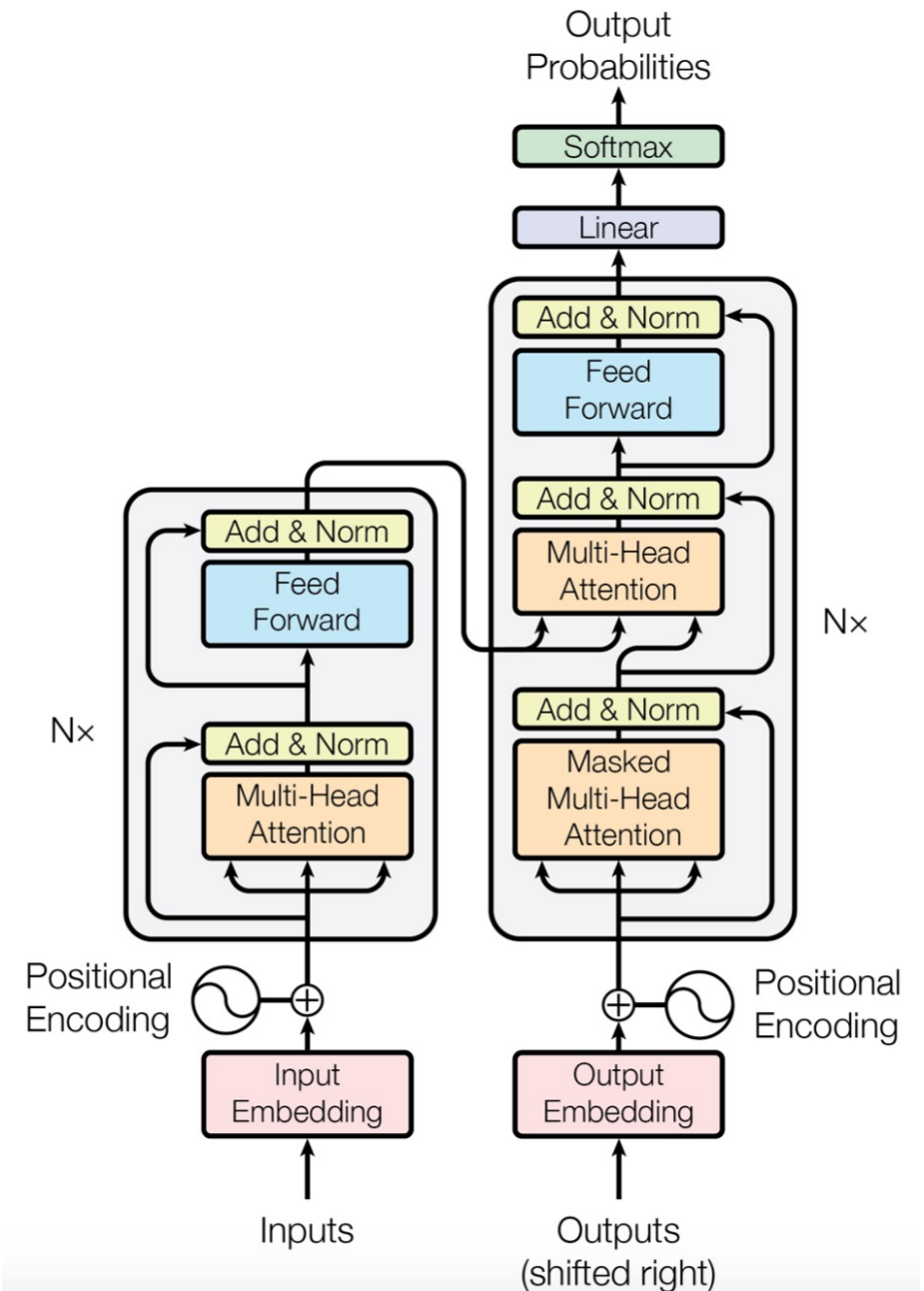

Performance Comparison

Table 1: Maximum path lengths, per-layer complexity and minimum number of sequential operations for different layer types. n is the sequence length, d is the representation dimension, k is the kernel size of convolutions and r the size of the neighborhood in restricted self-attention.

Layer Type	Complexity per Layer	Sequential Operations	Maximum Path Length
Self-Attention	$O(n^2 \cdot d)$	$O(1)$	$O(1)$
Recurrent	$O(n \cdot d^2)$	$O(n)$	$O(n)$
Convolutional	$O(k \cdot n \cdot d^2)$	$O(1)$	$O(\log_k(n))$
Self-Attention (restricted)	$O(r \cdot n \cdot d)$	$O(1)$	$O(n/r)$

Pretraining Language Models

- Can we use large amounts of text data to pretrain language models?
- Considerations:
 - ▶ How can we fuse both left-right and right-left context?
 - ▶ How can we facilitate non-trivial interactions between input tokens?
- Previous approaches:
 - ▶ ELMO (Peters. et. al., 2017): Bidirectional, but shallow.
 - ▶ GPT (Radford et. al., 2018): Deep, but unidirectional.
 - ▶ BERT (Devlin et. al., 2018): Deep and bidirectional!

BERT Workflow

- The BERT workflow includes:
 - ▶ Pretrain on generic, self-supervised tasks, using large amounts of data (like all of Wikipedia)
 - ▶ Fine-tune on specific tasks with limited, labelled data.
- The pretraining tasks (will talk about this in more detail later):
 - ▶ Masked Language Modelling (to learn contextualized token representations)
 - ▶ Next Sentence Prediction (summary vector for the whole input)

BERT Architecture

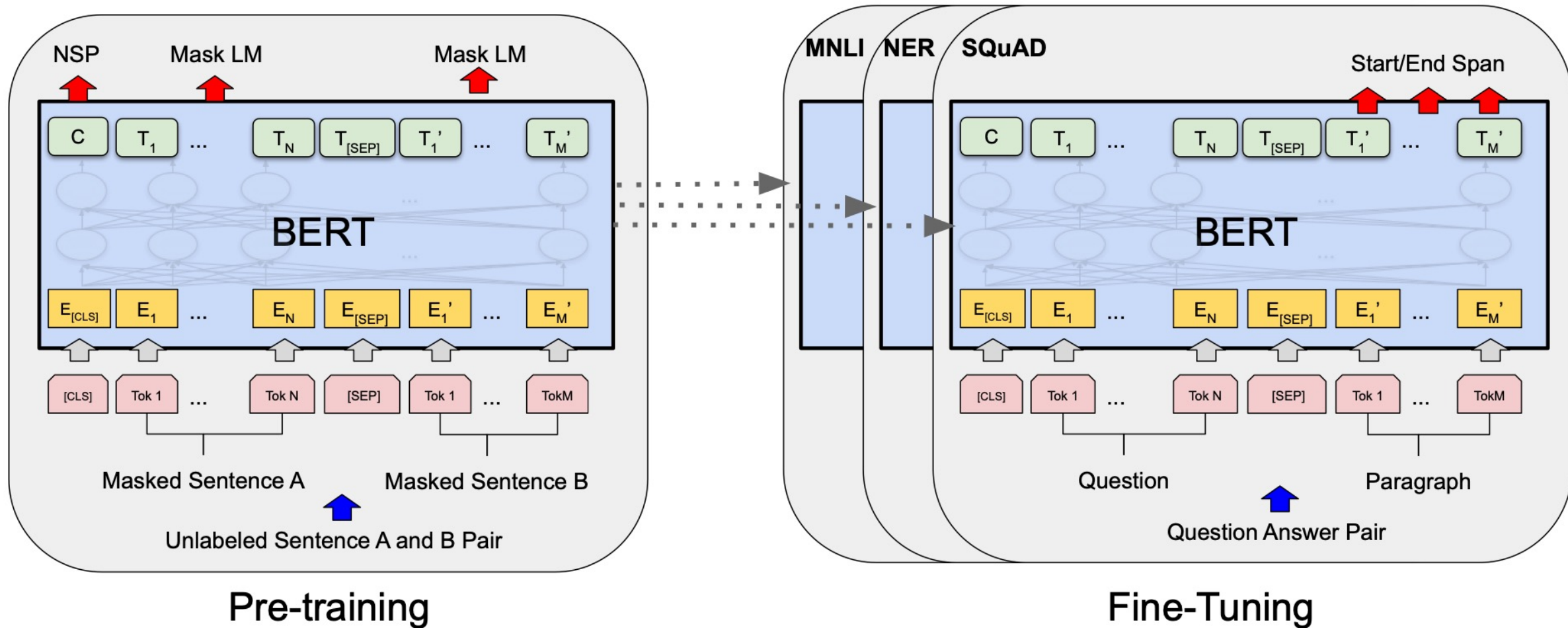

BERT Architecture

Properties:

- Two input sequences.
 - ▶ Many NLP tasks have two inputs (question answering, paraphrase detection, entailment detection etc.)
- Computes embeddings
 - ▶ Both token, position and segment embeddings.
 - ▶ Special start and separation tokens.
- Architecture
 - ▶ Basically the same as transformer encoder.
- Outputs:
 - ▶ Contextualized token representations.
 - ▶ Special tokens for context.

BERT Embeddings

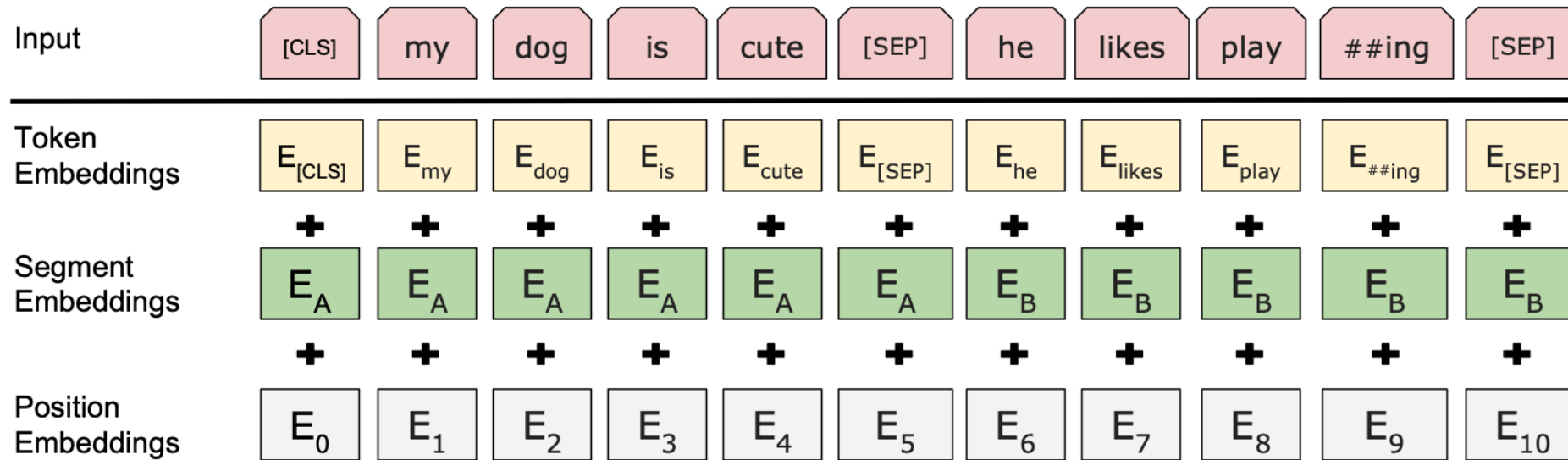

Figure 2: BERT input representation. The input embeddings are the sum of the token embeddings, the segmentation embeddings and the position embeddings.

- How we tokenize the inputs is very important!
- BERT uses the WordPiece tokenizer (Wu et. al. 2016)

(Aside) Tokenizers

- Tokenizers have to balance the following:
 - Being comprehensive (rare words? translation to different languages)
 - Total number of tokens
 - How semantically meaningful each token is.
- This is an activate area of research.

Pretraining tasks

- Masked Language Modelling, i.e. Cloze Task (Taylor, 1953)
- Next sentence prediction

Masked Language Modelling

- Mask 15% of the input tokens. (i.e. replace with a dummy masking token)
- Run the model, obtain the embeddings for the masked tokens.
- Using these embeddings, try to predict the missing token.
- "I love to eat peanut ___ and jam. " Can you guess what's missing?
- This procedure forces the model to encode context information in the features of all of the tokens.

Next Sentence Prediction

- Goal is to summarize the complete context (i.e. the two segments) in a single feature vector.
- Procedure for generating data
 - ▶ Pick a sentence from the training corpus and feed it as "segment A".
 - ▶ With 50% probability, pick the following sentence and feed that as "segment B".
 - ▶ With 50% probability, pick the a random sentence and feed it as "segment B".
- Using the features for the context token, predict whether segment B is the following sentence of segment A.
- Turns out to be a very effective pretraining technique!

Fine Tuning

Procedure:

- Add a final layer on top of BERT representations.
- Train the whole network on the fine-tuning dataset.
- Pre-training time: In the order of days on TPUs.
- Fine tuning task: Takes only a few hours max.

Fine Tuning

System	MNLI-(m/mm)	QQP	QNLI	SST-2	CoLA	STS-B	MRPC	RTE	Average
	392k	363k	108k	67k	8.5k	5.7k	3.5k	2.5k	-
Pre-OpenAI SOTA	80.6/80.1	66.1	82.3	93.2	35.0	81.0	86.0	61.7	74.0
BiLSTM+ELMo+Attn	76.4/76.1	64.8	79.8	90.4	36.0	73.3	84.9	56.8	71.0
OpenAI GPT	82.1/81.4	70.3	87.4	91.3	45.4	80.0	82.3	56.0	75.1
BERT _{BASE}	84.6/83.4	71.2	90.5	93.5	52.1	85.8	88.9	66.4	79.6
BERT _{LARGE}	86.7/85.9	72.1	92.7	94.9	60.5	86.5	89.3	70.1	82.1

Table 1: GLUE Test results, scored by the evaluation server (<https://gluebenchmark.com/leaderboard>). The number below each task denotes the number of training examples. The “Average” column is slightly different than the official GLUE score, since we exclude the problematic WNLI set.⁸ BERT and OpenAI GPT are single-model, single task. F1 scores are reported for QQP and MRPC, Spearman correlations are reported for STS-B, and accuracy scores are reported for the other tasks. We exclude entries that use BERT as one of their components.

Self-Supervised Learning in Vision

Context Prediction

Model predicts relative location of two patches from the same image.

Discriminative pretraining task

Intuition: Requires understanding objects and their parts

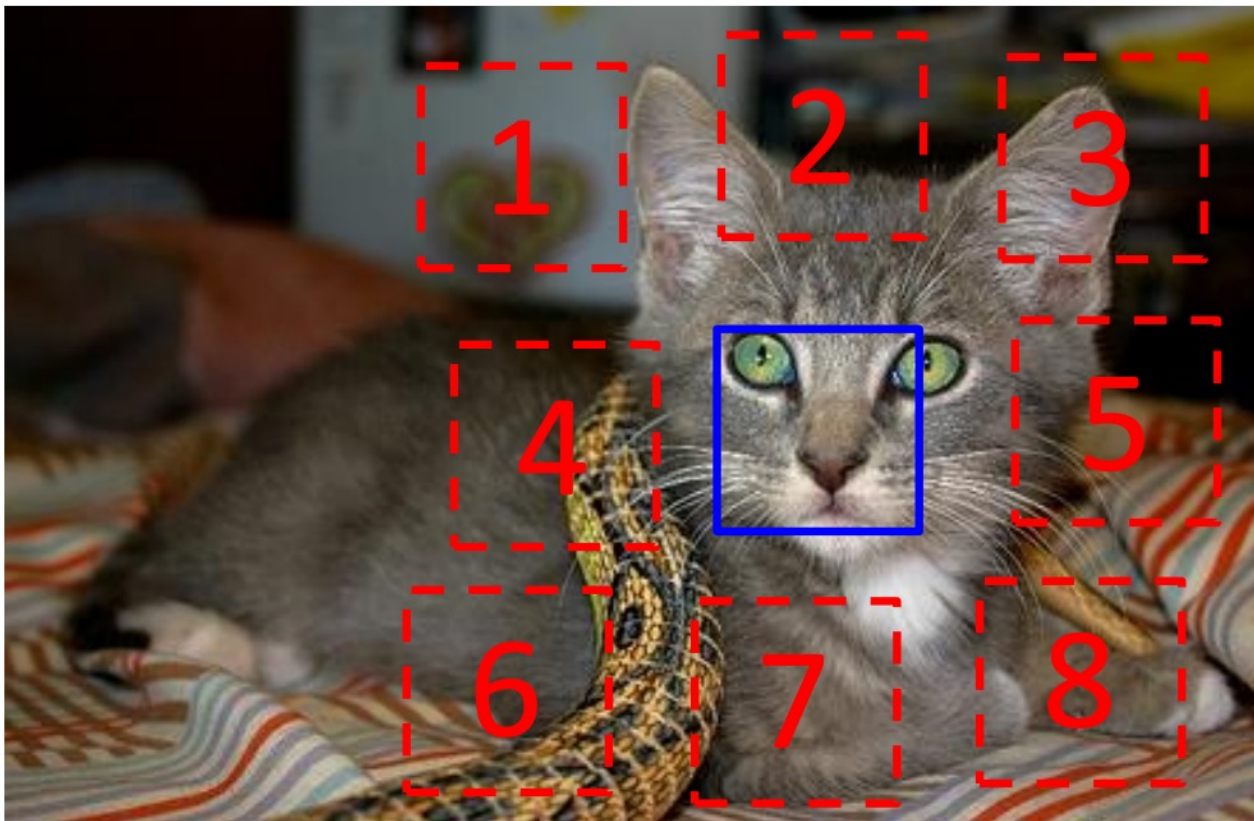

$$X = \left(\begin{array}{c} \text{[Kitten Face Patch]} \\ \text{[Kitten Ear Patch]} \end{array} \right); Y = 3$$

Context Prediction

Model predicts relative location of two patches from the same image.

Discriminative pretraining task

Intuition: Requires understanding objects and their parts

Classification over 8 positions

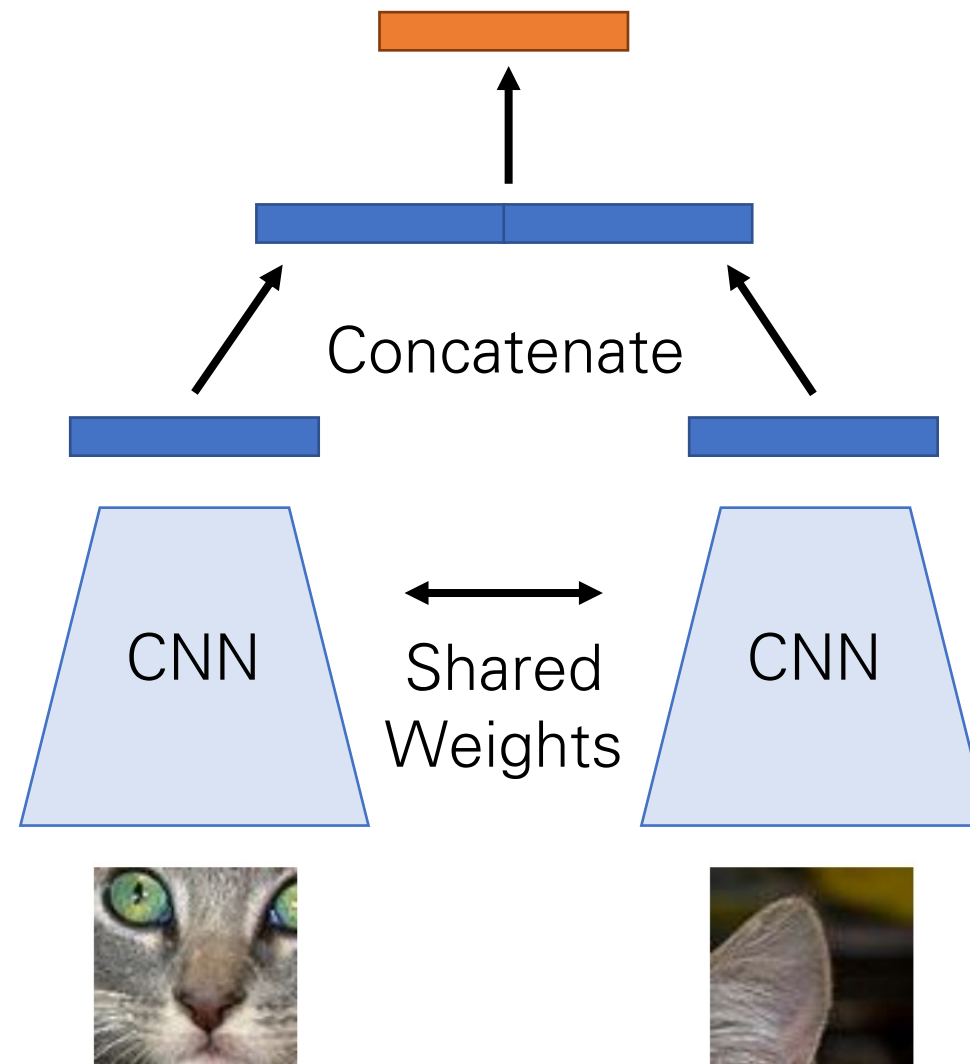

Context Prediction

Model predicts relative location of two patches from the same image.

Discriminative pretraining task

Intuition: Requires understanding objects and their parts

Two networks with shared weights sometimes called a "Siamese network"

Classification over 8 positions

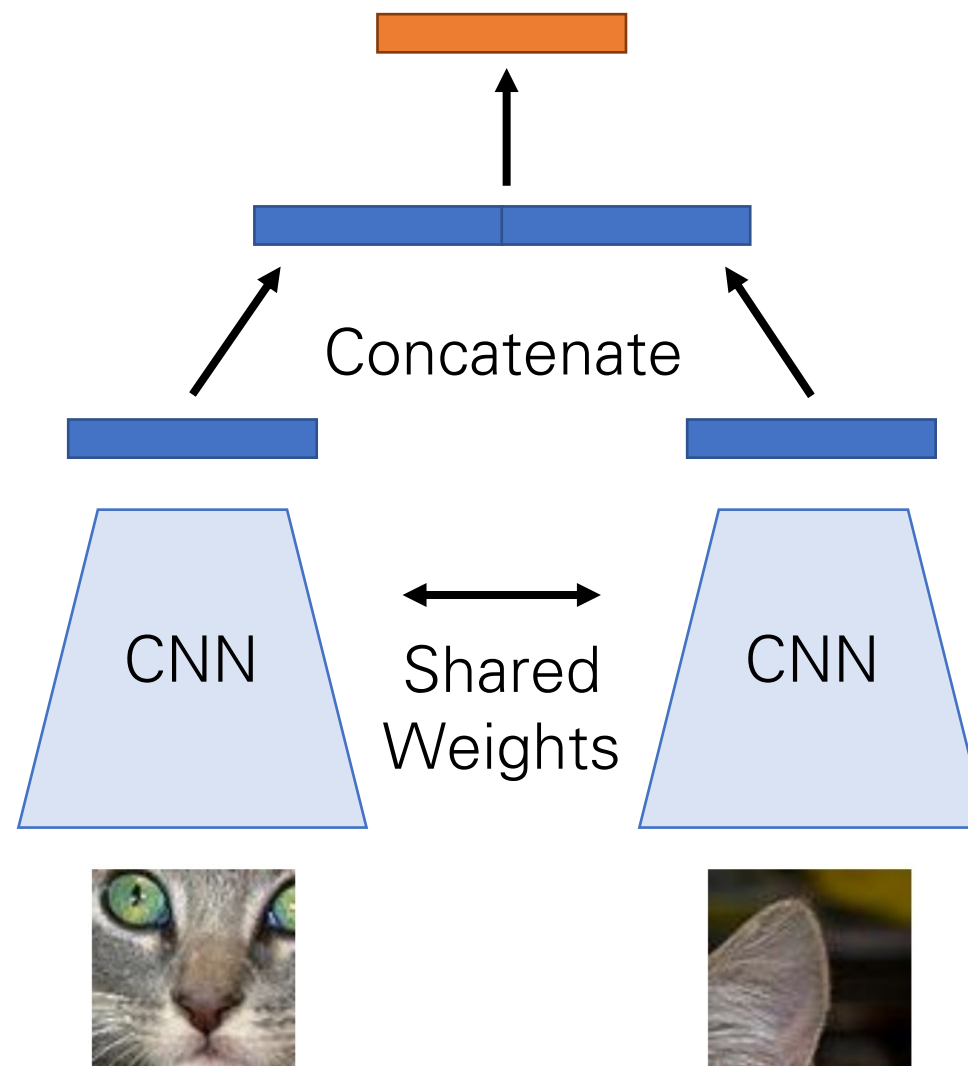

Context Prediction

Model predicts relative location of two patches from the same image.

Discriminative pretraining task

Intuition: Requires understanding objects and their parts

“For experiments, we use a ConvNet trained on a K40 GPU for approximately four weeks.”

Classification over 8 positions

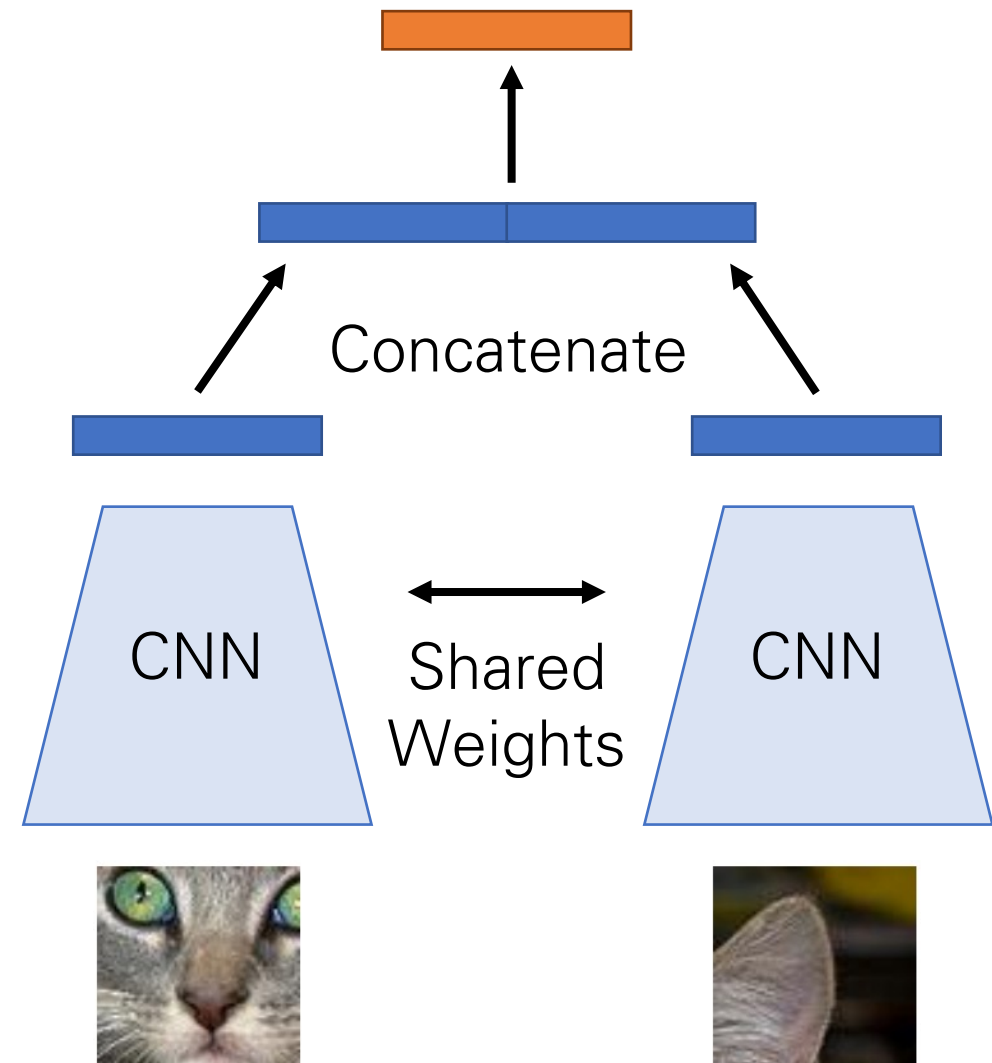

Context Prediction: Nearest Neighbors in Feature Space

Input Patch



Context Prediction: Nearest Neighbors in Feature Space

Input Patch

Random Init

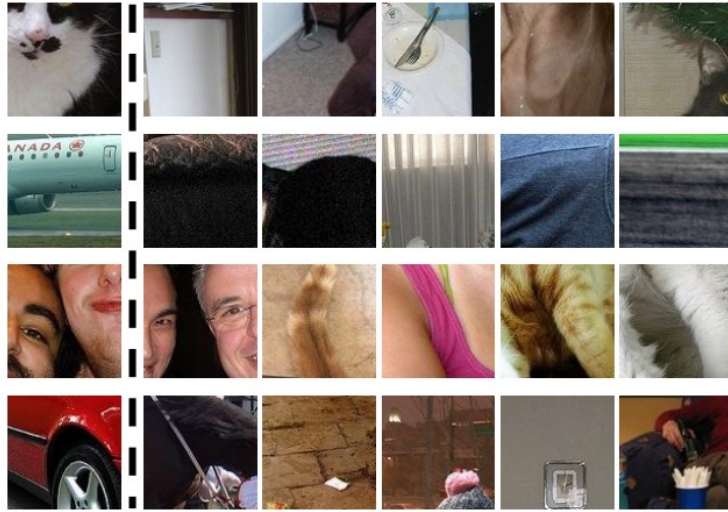

Context Prediction: Nearest Neighbors in Feature Space

Input Patch

Random Init

Supervised AlexNet

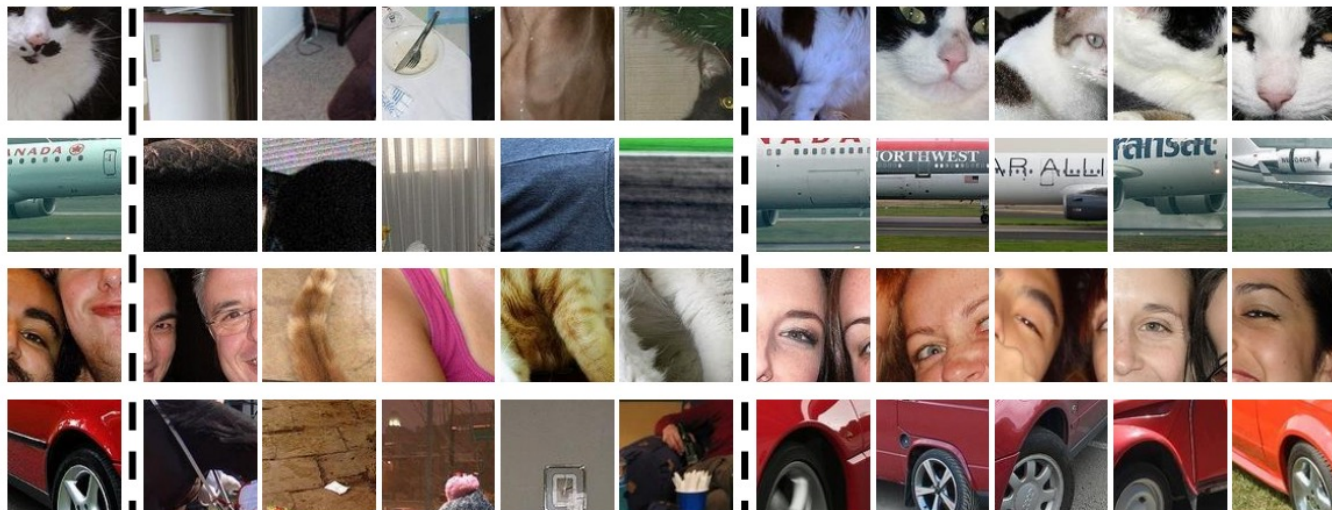

Context Prediction: Nearest Neighbors in Feature Space

Input Patch

Random Init

Supervised AlexNet

Their Features

Works well!
Similar to AlexNet

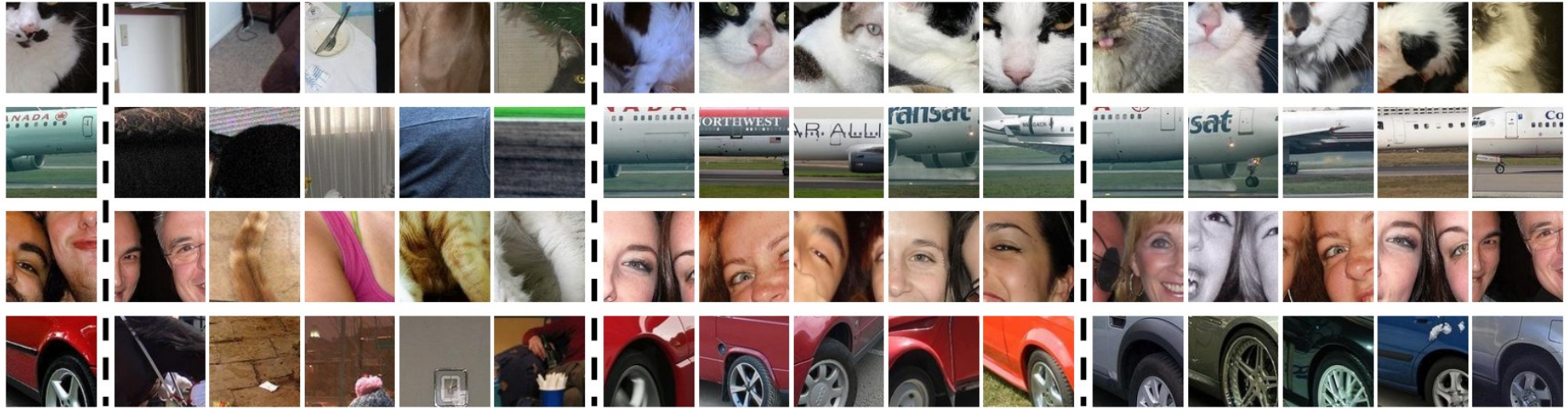

Context Prediction: Nearest Neighbors in Feature Space

Input Patch

Random Init

Supervised AlexNet

Their Features

Works well!
Similar to AlexNet

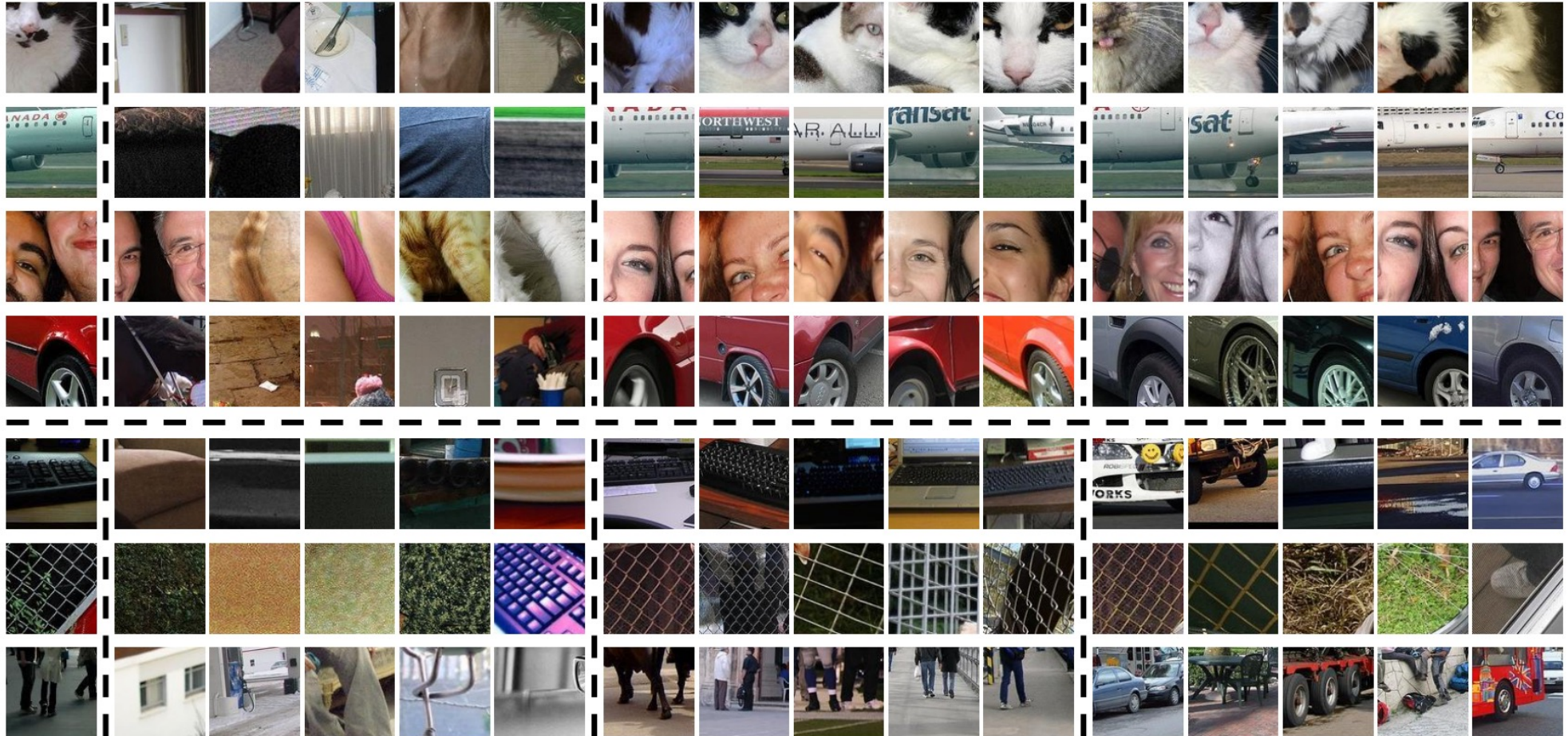

Failure modes

Jigsaw puzzles

Rather than predict relative position of two patches, instead predict permutation to “unscramble” 9 shuffled patches

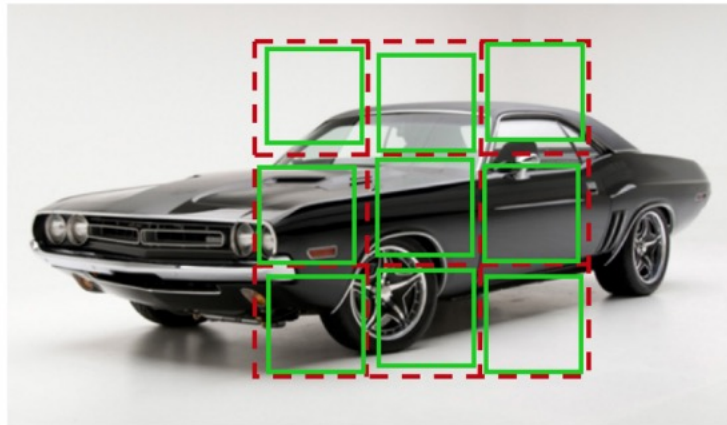

Permutation Set

index	permutation
64	9,4,6,8,3,2,5,1,7

Reorder patches according to the selected permutation

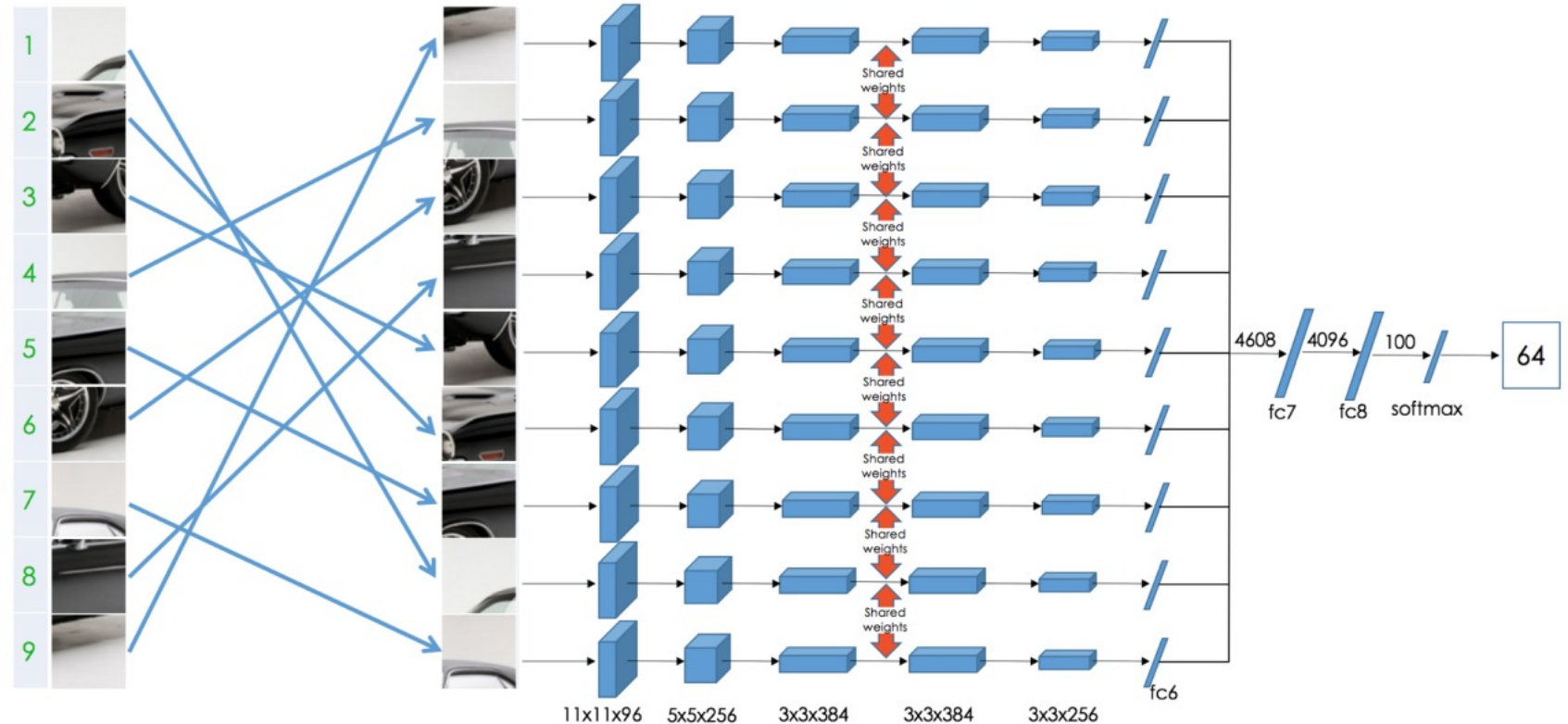

Jigsaw puzzles

Problem: These methods only work on patches, not whole images!

Rather than predict relative position of two patches, instead predict permutation to “unscramble” 9 shuffled patches

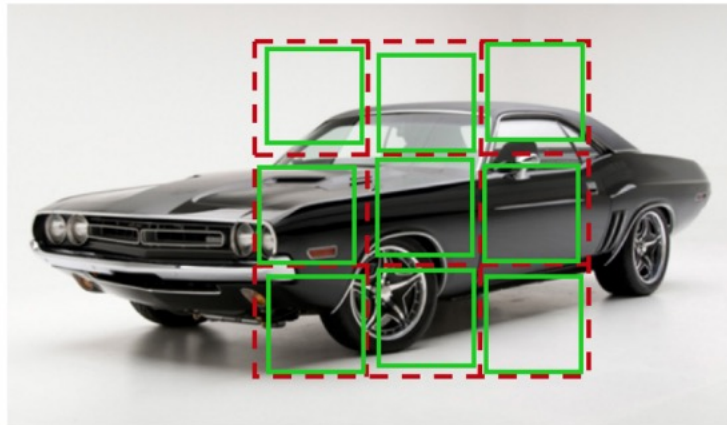

Permutation Set

index	permutation
64	9,4,6,8,3,2,5,1,7

Reorder patches according to the selected permutation

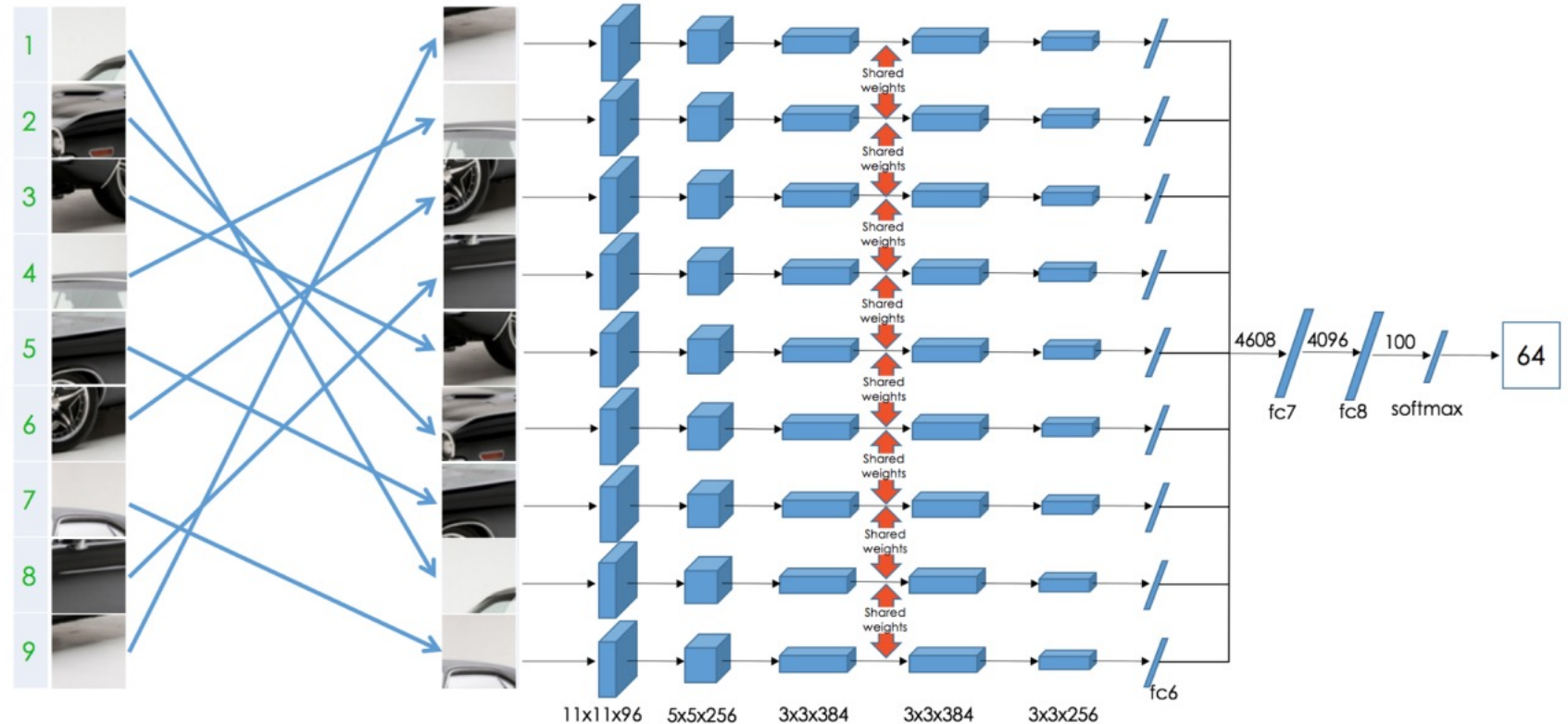

Context Encoders: Learning by Inpainting

- The most obvious analogy to word embeddings: predict parts of image from remainder of image.

Context Encoders: Learning by Inpainting

- The most obvious analogy to word embeddings: predict parts of image from remainder of image.



(a) Input context



(b) Human artist

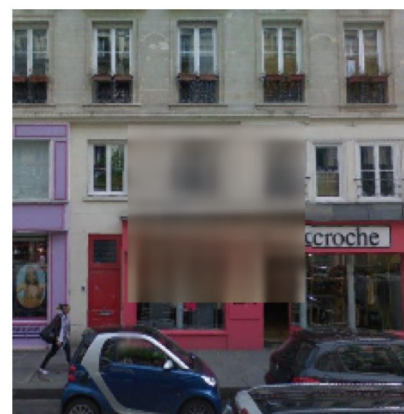

(c) Context Encoder
(L_2 loss)



(d) Context Encoder
($L_2 + \text{Adversarial loss}$)

Context Encoders: Learning by Inpainting

- The most obvious analogy to word embeddings: predict parts of image from remainder of image.

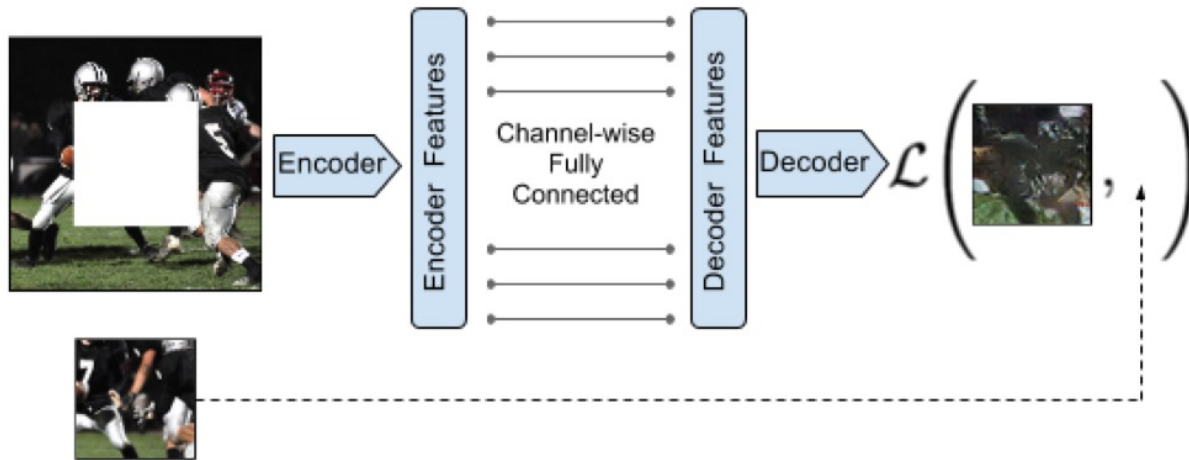

Architecture:

An encoder E takes a part of image, constructs a representation.

A decoder D takes representation, tries to reconstruct missing part.

- **Much** trickier than in NLP:
As we have seen, meaningful losses for vision are much more difficult to design. Choice of region to mask out is much more impactful.

Context Encoders: Learning by Inpainting

Input Image

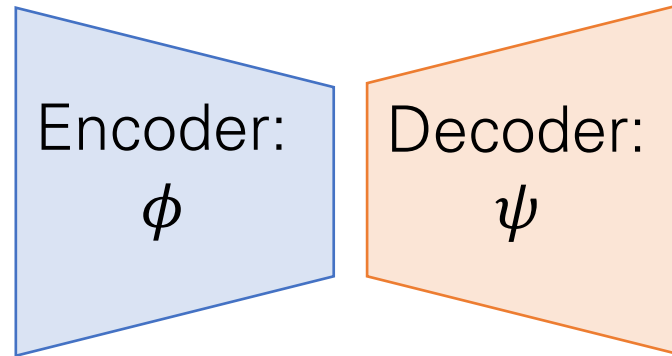

Context Encoders: Learning by Inpainting

Input Image



Encoder:
 ϕ

Decoder:
 ψ

Predict Missing Pixels



Human Artist

Context Encoders: Learning by Inpainting

Input Image



Encoder:
 ϕ

Decoder:
 ψ

Predict Missing Pixels



L2 Loss
(Best for feature learning)

Context Encoders: Learning by Inpainting

Input Image



Encoder:
 ϕ

Decoder:
 ψ

Predict Missing Pixels

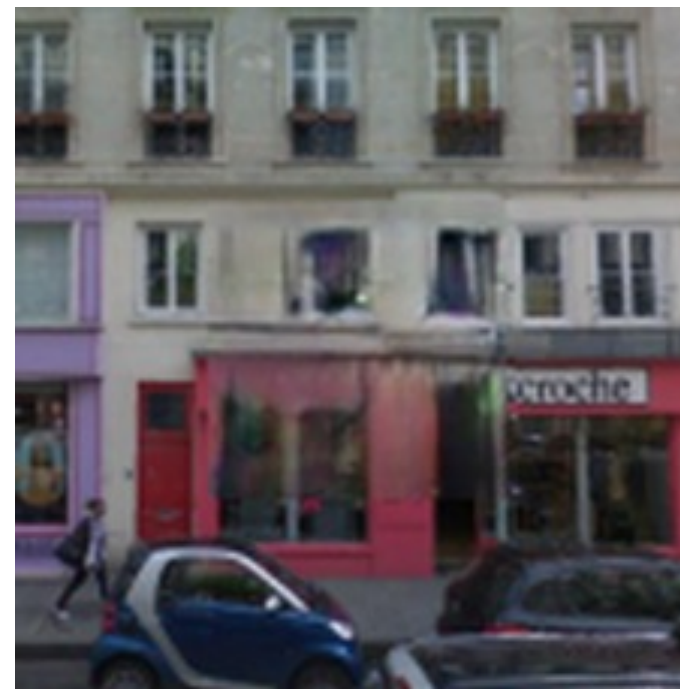

L2 + Adversarial Loss
(Best for nice images)

Inpainting

- The most obvious analogy to word embeddings: predict parts of image from remainder of image.
- How to choose the region?

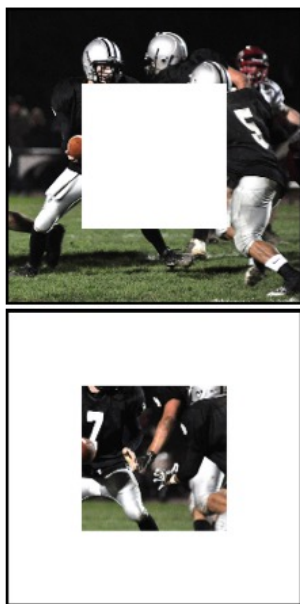

(a) Central region

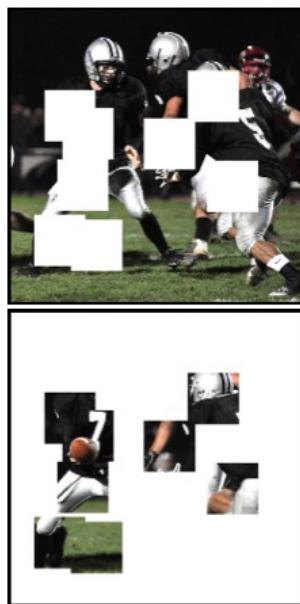

(b) Random block

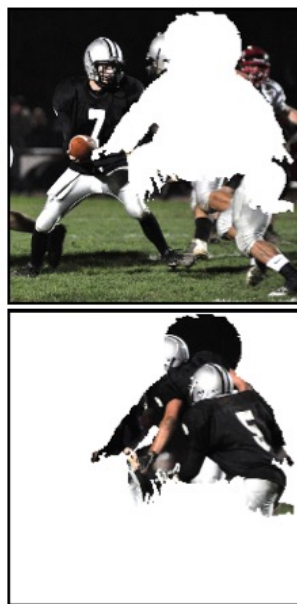

(c) Random region

Task should be “solvable”, but not “too easy”.

- Fixed (central region): tends to produce less generalizable representations
- Random blocks: slightly better, but square borders still hurt.
- Random silhouette (fully random doesn't make sense – prediction task is too ill-defined) – even better!

Predicting rotations

- In principle, what we want is a task “hard enough”, that any model that does well on it, should learn something “meaningful” about the task.
- **Task:** predict one of 4 possible rotations of an image.

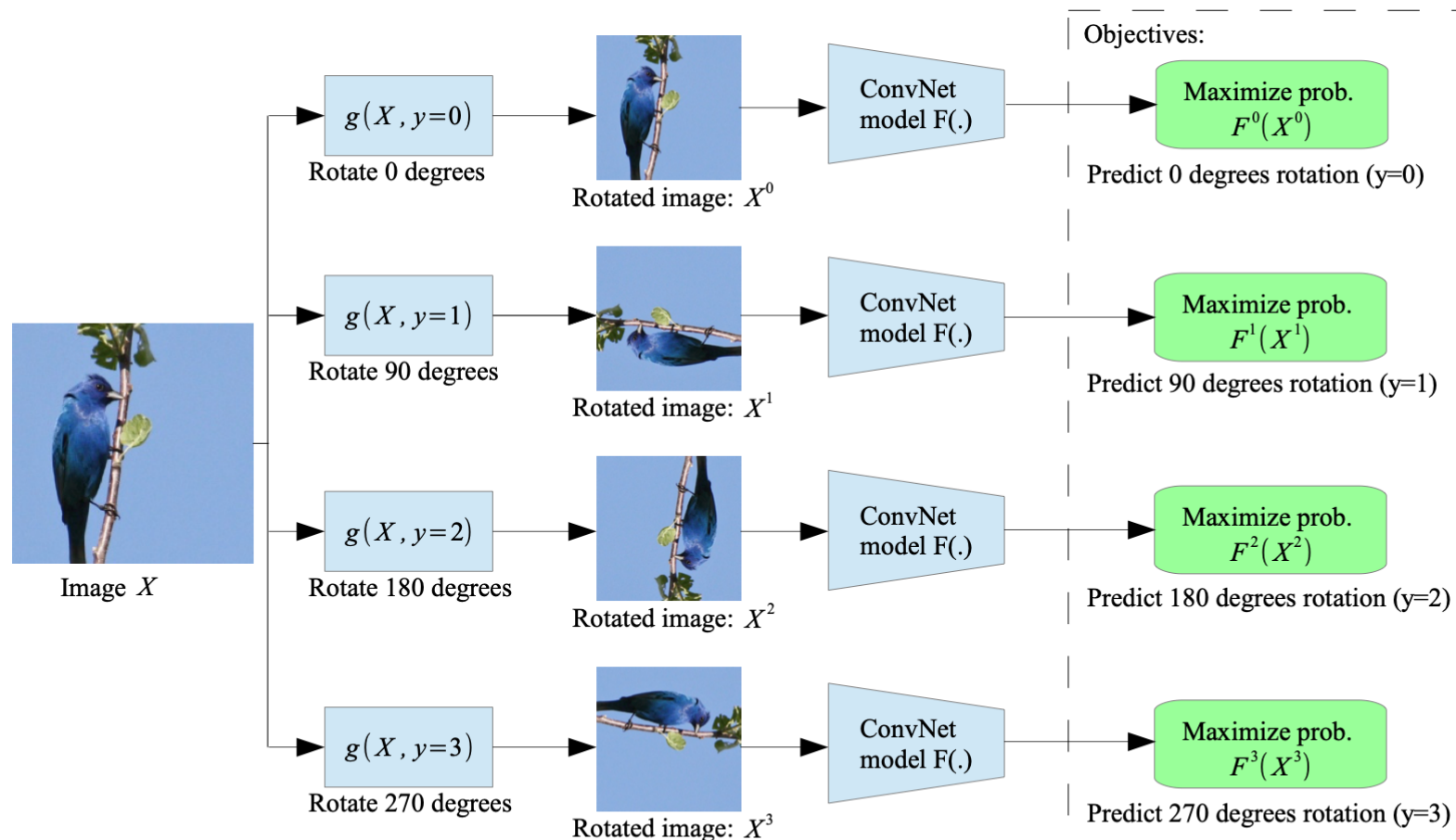

Predicting rotations

- In principle, what we want is a task “hard enough”, that any model that does well on it, should learn something “meaningful” about the task.
- **Task:** predict one of 4 possible rotations of an image.
- **Representation:** penultimate layer of a neural net used to solve task.
- **Intuition:** a rotation is a global transformation. ConvNets are much better at capturing local transformations (as convolutions are local), so there is no obvious way to “cheat”.

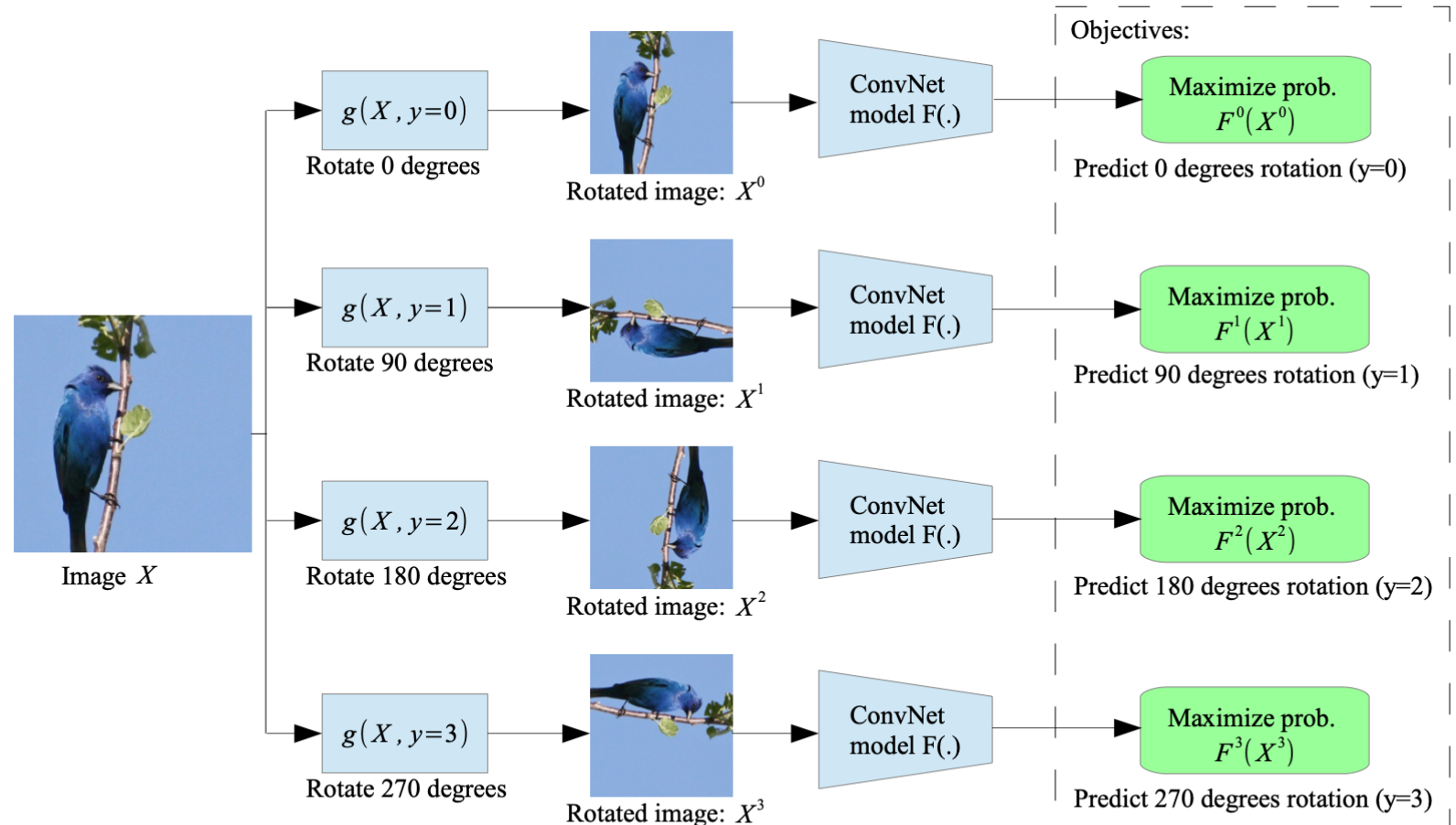

Predicting rotations

- In principle, what we want is a task “hard enough”, that any model that does well on it, should learn something “meaningful” about the task.
- **Task:** predict one of 4 possible rotations of an image.
 - Less finicky to get right: no obvious artifacts the model can make use of to cheat.
 - The 90 deg. rotations also don't introduce any additional artifacts due to discretization.

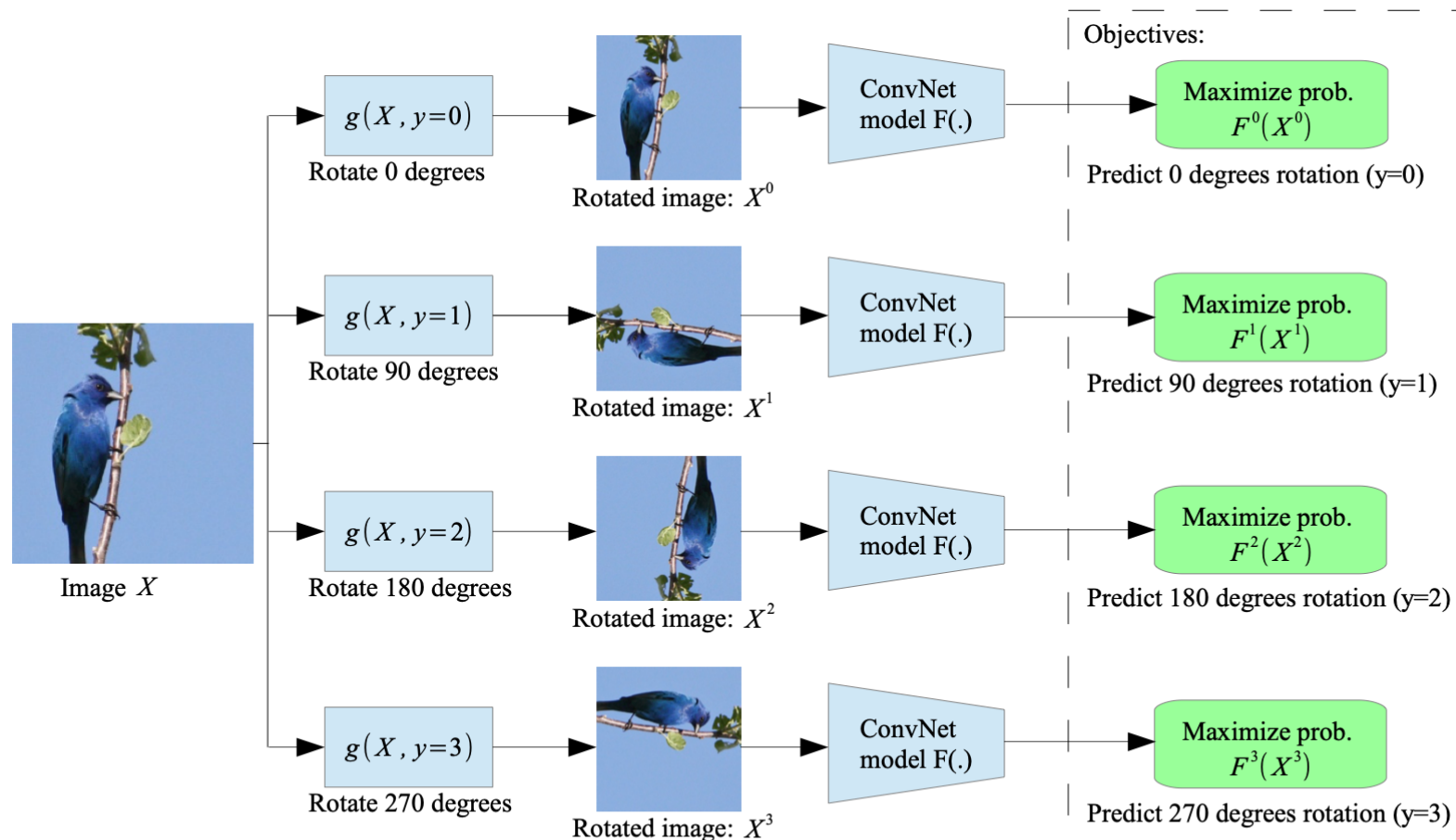
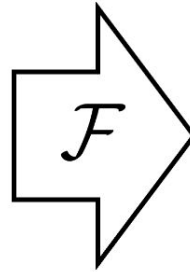
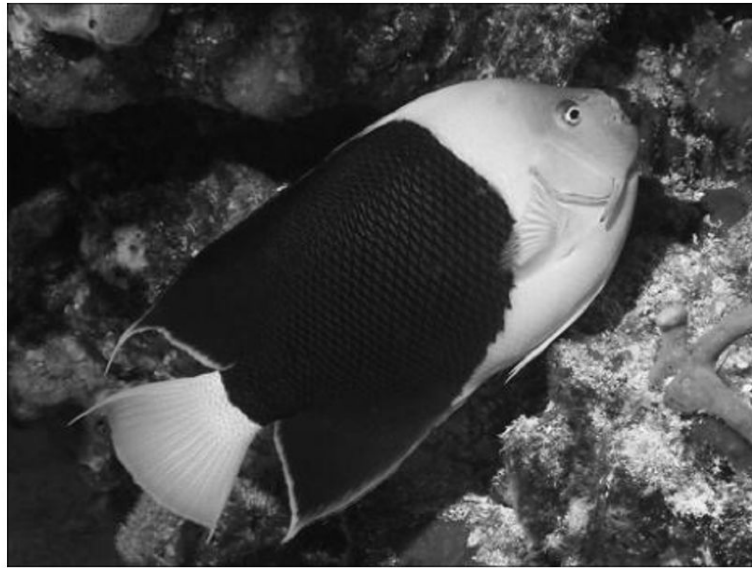

Image coloring



Grayscale image: L channel

$$\mathbf{X} \in \mathbb{R}^{H \times W \times 1}$$

Color information: ab channels

$$\hat{\mathbf{Y}} \in \mathbb{R}^{H \times W \times 2}$$

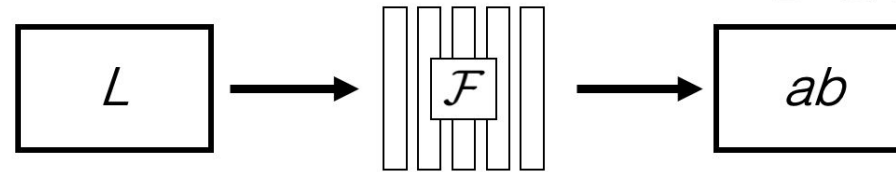

5

Image coloring

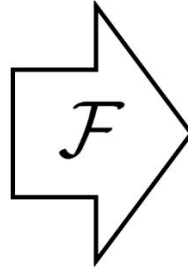
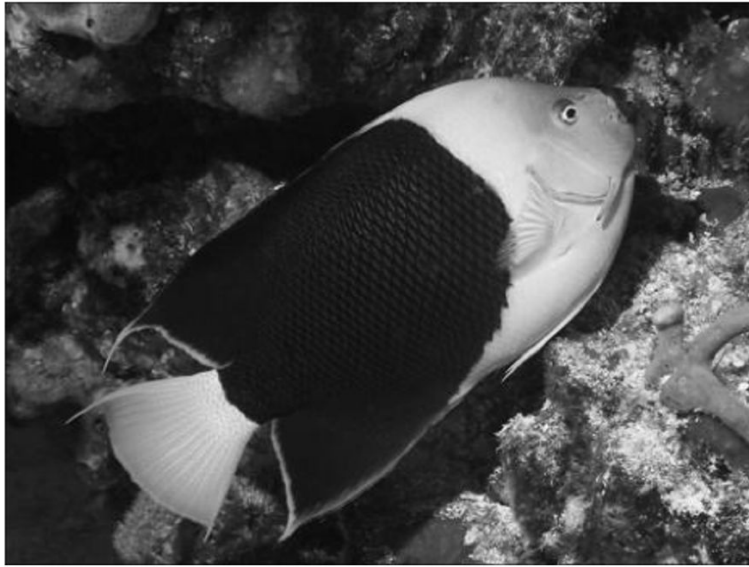

Grayscale image: L channel

$$\mathbf{X} \in \mathbb{R}^{H \times W \times 1}$$

Concatenate (L, ab) channels

$$(\mathbf{X}, \hat{\mathbf{Y}})$$

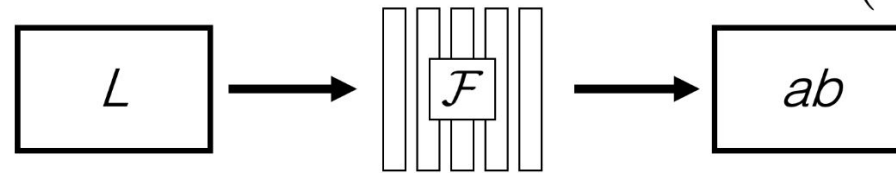

Learning features from colorization: Split-brain Autoencoder

- Idea: cross-channel predictions

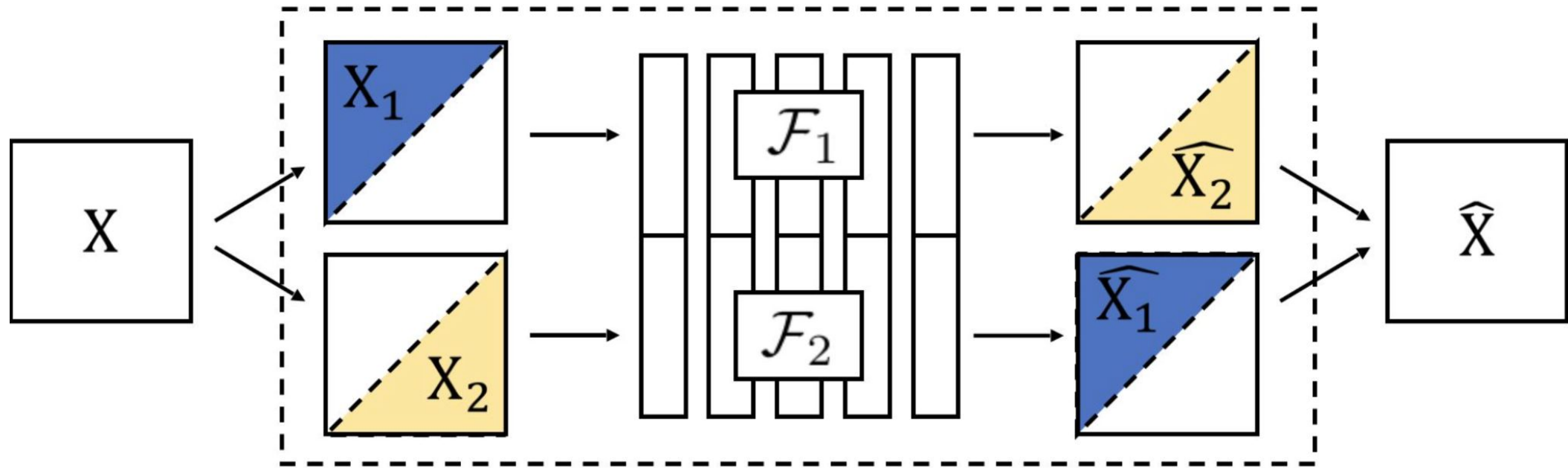

Split-Brain Autoencoder

Learning features from colorization: Split-brain Autoencoder

- Idea: cross-channel predictions

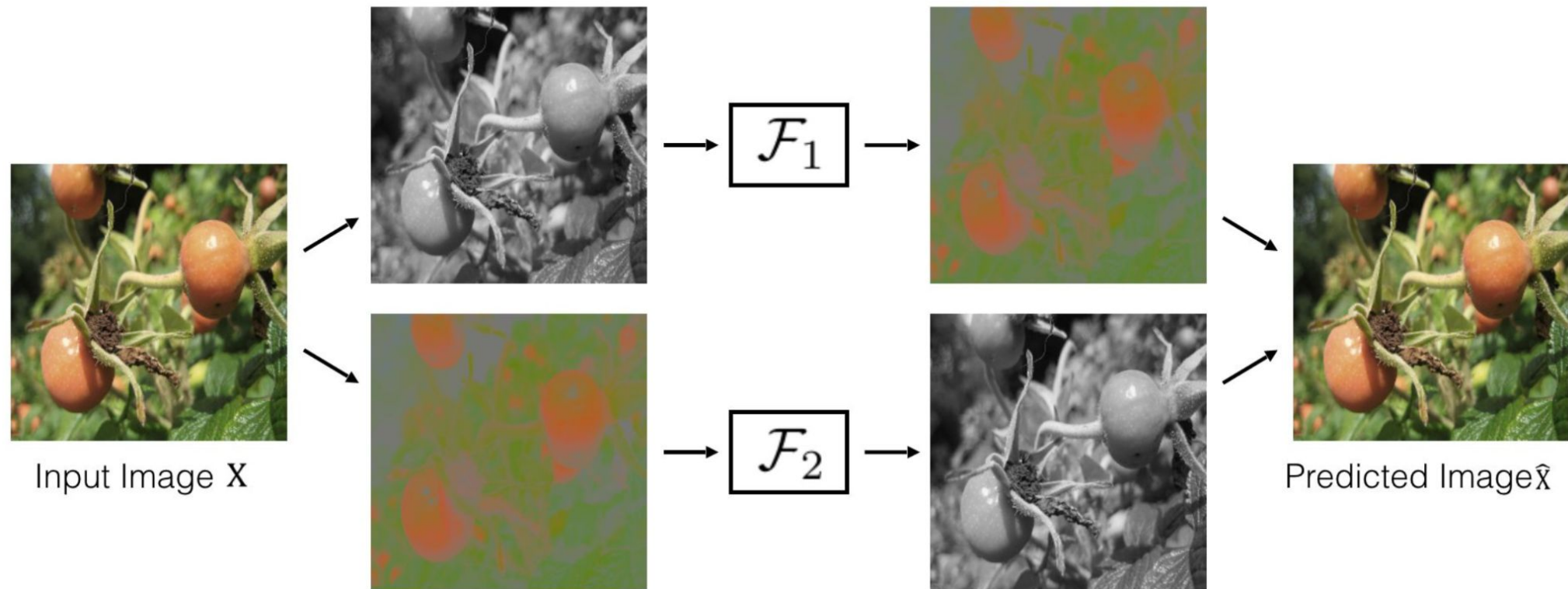

Split-Brain Autoencoder

Learning features from colorization: Split-brain Autoencoder

- Idea: cross-channel predictions

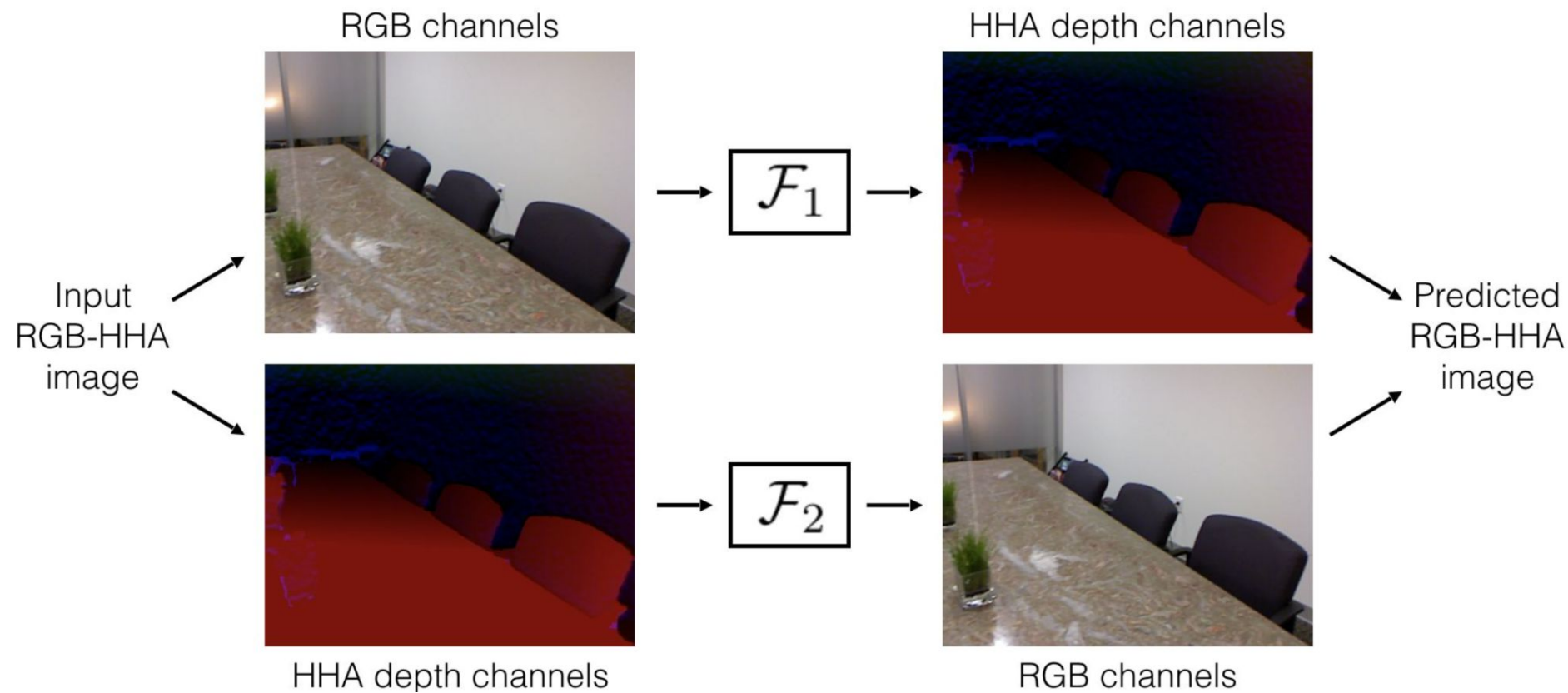

Split-Brain Autoencoder

Split-brain Autoencoder: Transfer learned features to supervised learning

- Self-supervised learning on ImageNet (entire training set).
- Use concatenated features from F_1 and F_2
- Labeled data is from the Places (Zhou 2016).

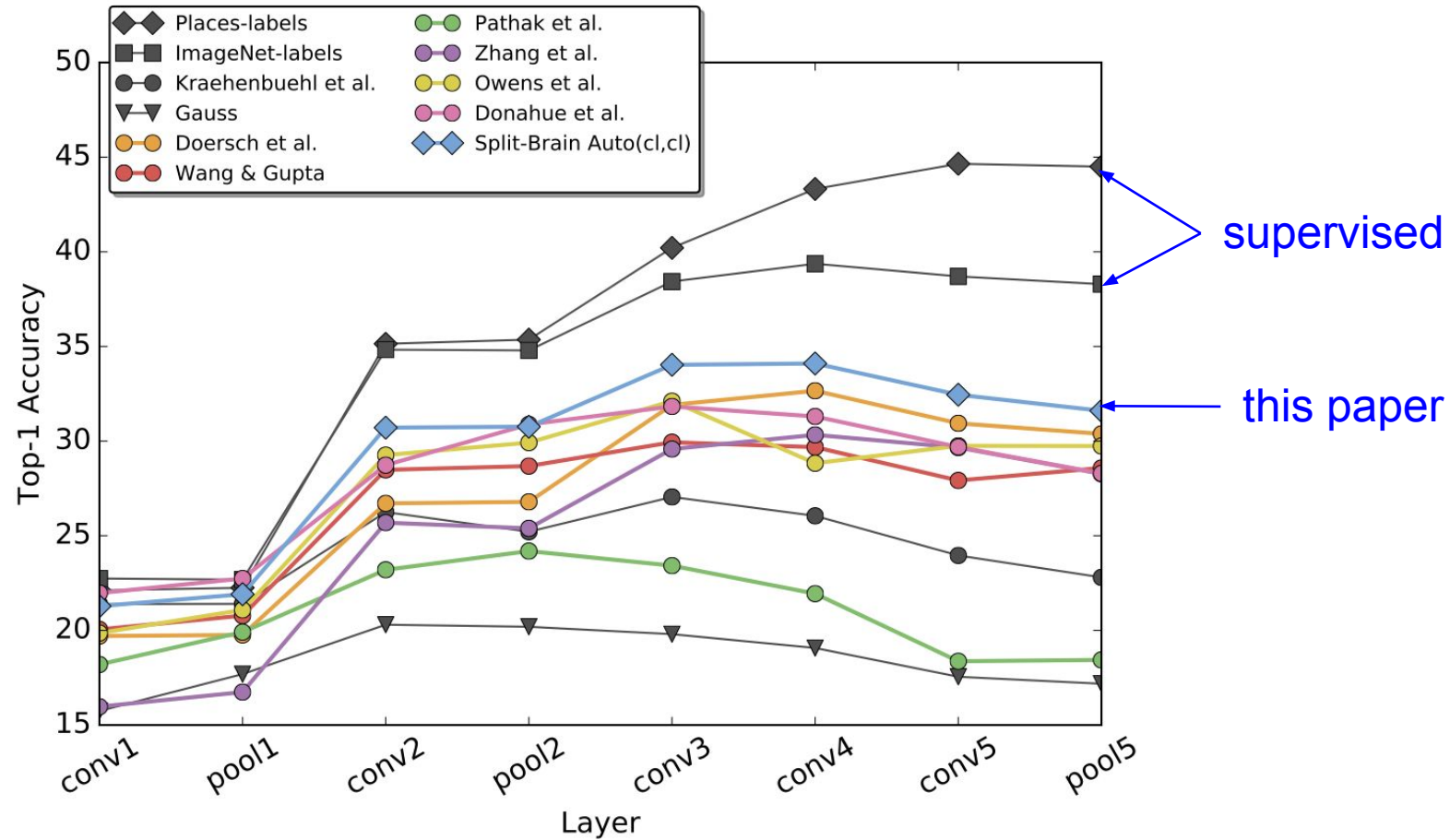

Contrastive Representation Learning

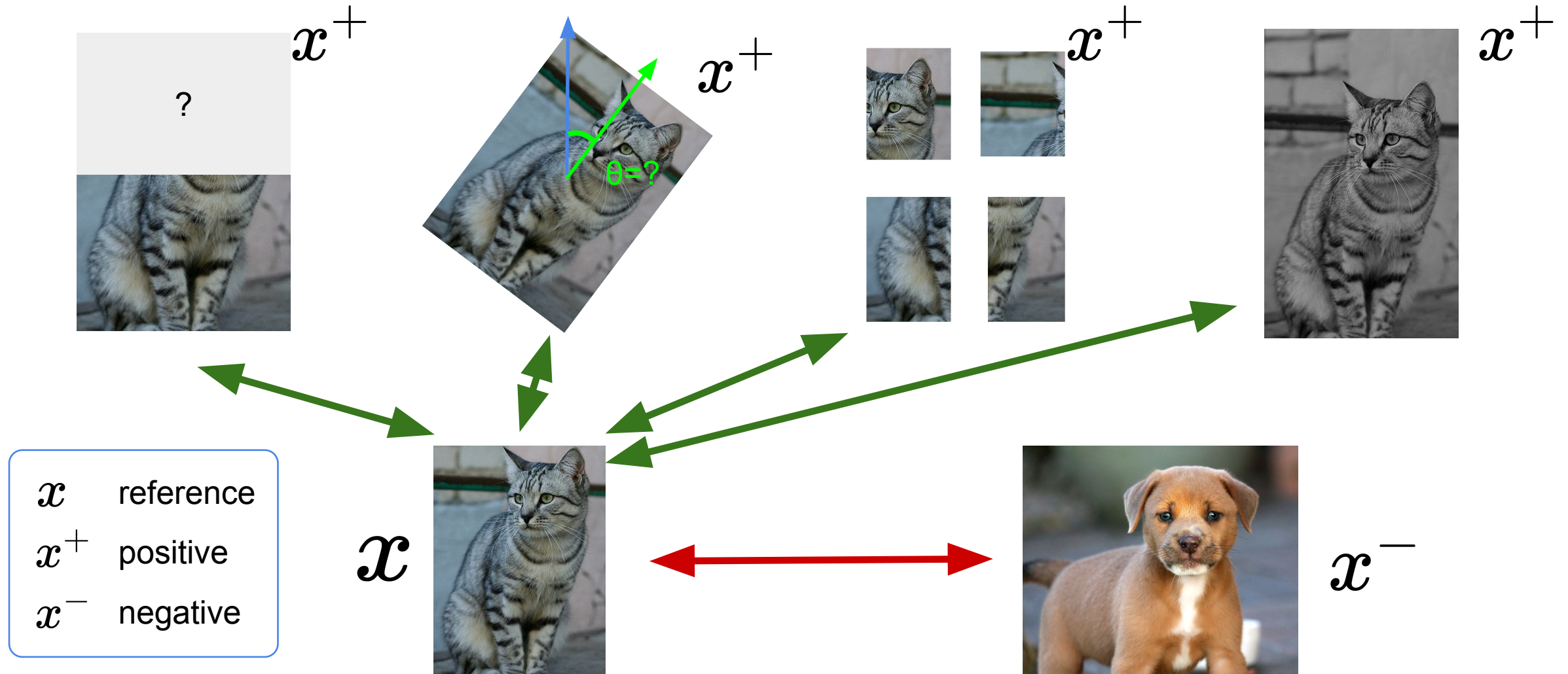

A formulation of contrastive learning

- What we want:

$$\text{score}(f(x), f(x^+)) \gg \text{score}(f(x), f(x^-))$$

- x : reference sample; x^+ positive sample; x^- negative sample
- Given a chosen score function, we aim to learn an **encoder function** f that yields high score for positive pairs (x, x^+) and low scores for negative pairs (x, x^-) .

A formulation of contrastive learning

- Loss function given 1 positive sample and $N - 1$ negative samples:

$$L = -\mathbb{E}_X \left[\log \frac{\exp(s(f(x), f(x^+)))}{\exp(s(f(x), f(x^+))) + \sum_{j=1}^{N-1} \exp(s(f(x), f(x_j^-)))} \right]$$

A formulation of contrastive learning

- Loss function given 1 positive sample and $N - 1$ negative samples:

$$L = -\mathbb{E}_X \left[\log \frac{\overbrace{\exp(s(f(x), f(x^+)))}}{\underbrace{\exp(s(f(x), f(x^+))) + \sum_{j=1}^{N-1} \exp(s(f(x), f(x_j^-)))}} \right]$$



x



x^+



x



x_1^-



x_2^-



x_3^-

...

A formulation of contrastive learning

- Loss function given 1 positive sample and N - 1 negative samples:

$$L = -\mathbb{E}_X \left[\log \frac{\overbrace{\exp(s(f(x), f(x^+)))}^{\text{score for the positive pair}}}{\underbrace{\exp(s(f(x), f(x^+)))}_{\text{score for the positive pair}} + \underbrace{\sum_{j=1}^{N-1} \exp(s(f(x), f(x_j^-)))}_{\text{score for the N-1 negative pairs}}} \right]$$

- This seems familiar..

A formulation of contrastive learning

- Loss function given 1 positive sample and N - 1 negative samples:

$$L = -\mathbb{E}_{\mathcal{X}} \left[\log \frac{\overbrace{\exp(s(f(x), f(x^+)))}^{\text{score for the positive pair}}}{\underbrace{\exp(s(f(x), f(x^+)))}_{\text{score for the positive pair}} + \underbrace{\sum_{j=1}^{N-1} \exp(s(f(x), f(x_j^-)))}_{\text{score for the N-1 negative pairs}}} \right]$$

- This seems familiar..

Cross entropy loss for a N-way softmax classifier!

i.e., learn to find the positive sample from the N samples

A formulation of contrastive learning

- Loss function given 1 positive sample and $N - 1$ negative samples:

$$L = -\mathbb{E}_X \left[\log \frac{\exp(s(f(x), f(x^+)))}{\exp(s(f(x), f(x^+))) + \sum_{j=1}^{N-1} \exp(s(f(x), f(x_j^-)))} \right]$$

- Commonly known as the InfoNCE loss (van den Oord et al., 2018)
A lower bound on the mutual information between $f(x)$ and $f(x^+)$

$$MI[f(x), f(x^+)] - \log(N) \geq -L$$

- The larger the negative sample size (N), the tighter the bound

SimCLR: A Simple Framework for Contrastive Learning

- Cosine similarity as the score function:
$$s(\mathbf{u}, \mathbf{v}) = \frac{\mathbf{u}^T \mathbf{v}}{\|\mathbf{u}\| \|\mathbf{v}\|}$$
- Use a projection network $h(\cdot)$ to project features to a space where contrastive learning is applied.
- Generate positive samples through data augmentation:
 - random cropping, random color distortion, and random blur.

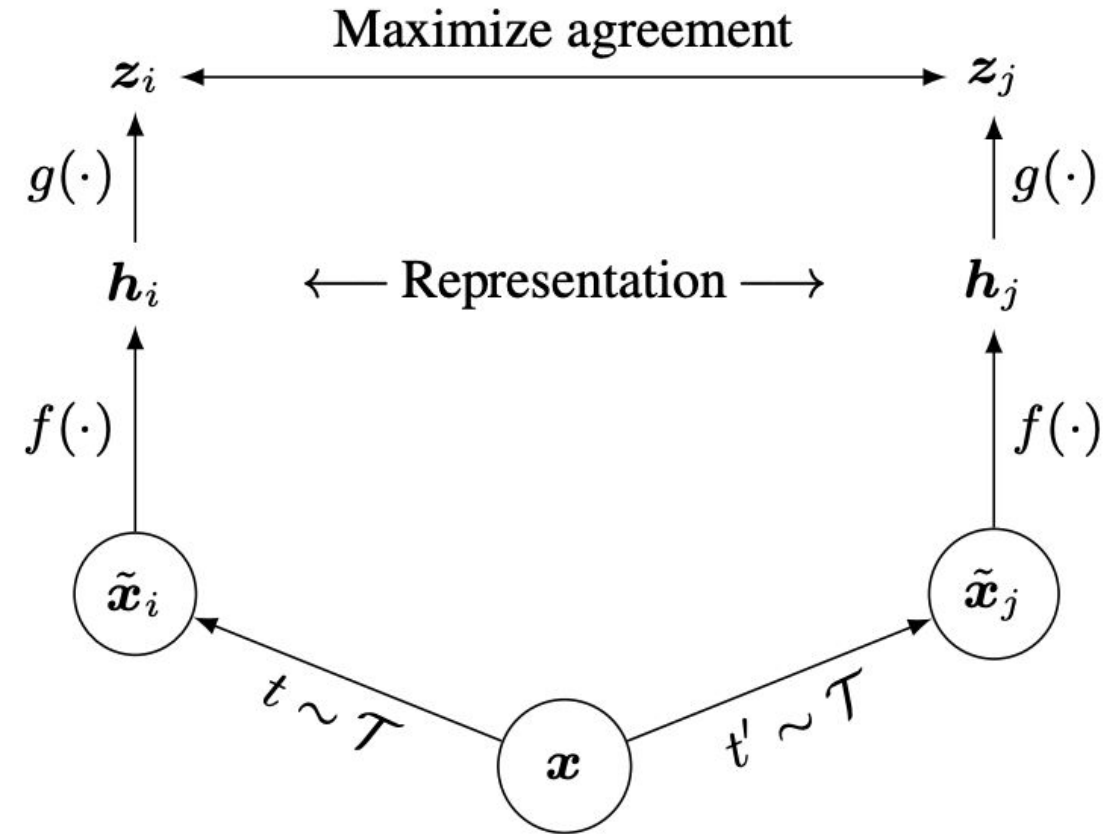

SimCLR: Generating positive samples from data augmentation



(a) Original



(b) Crop and resize



(c) Crop, resize (and flip)



(d) Color distort. (drop)



(e) Color distort. (jitter)



(f) Rotate $\{90^\circ, 180^\circ, 270^\circ\}$



(g) Cutout



(h) Gaussian noise



(i) Gaussian blur



(j) Sobel filtering

SimCLR: Generating positive samples from data augmentation

Algorithm 1 SimCLR's main learning algorithm.

input: batch size N , constant τ , structure of f, g, \mathcal{T} .

for sampled minibatch $\{\mathbf{x}_k\}_{k=1}^N$ **do**

for all $k \in \{1, \dots, N\}$ **do**

 draw two augmentation functions $t \sim \mathcal{T}, t' \sim \mathcal{T}$

 # the first augmentation

$\tilde{\mathbf{x}}_{2k-1} = t(\mathbf{x}_k)$

$\mathbf{h}_{2k-1} = f(\tilde{\mathbf{x}}_{2k-1})$

 # representation

$\mathbf{z}_{2k-1} = g(\mathbf{h}_{2k-1})$

 # projection

 # the second augmentation

$\tilde{\mathbf{x}}_{2k} = t'(\mathbf{x}_k)$

$\mathbf{h}_{2k} = f(\tilde{\mathbf{x}}_{2k})$

 # representation

$\mathbf{z}_{2k} = g(\mathbf{h}_{2k})$

 # projection

end for

for all $i \in \{1, \dots, 2N\}$ and $j \in \{1, \dots, 2N\}$ **do**

$s_{i,j} = \mathbf{z}_i^\top \mathbf{z}_j / (\|\mathbf{z}_i\| \|\mathbf{z}_j\|)$ # pairwise similarity

end for

define $\ell(i, j)$ **as** $\ell(i, j) = -\log \frac{\exp(s_{i,j}/\tau)}{\sum_{k=1}^{2N} \mathbb{1}_{[k \neq i]} \exp(s_{i,k}/\tau)}$

$\mathcal{L} = \frac{1}{2N} \sum_{k=1}^N [\ell(2k-1, 2k) + \ell(2k, 2k-1)]$

 update networks f and g to minimize \mathcal{L}

end for

return encoder network $f(\cdot)$, and throw away $g(\cdot)$

Generate a positive pair
by sampling data
augmentation functions

SimCLR: Generating positive samples from data augmentation

Algorithm 1 SimCLR's main learning algorithm.

input: batch size N , constant τ , structure of f, g, \mathcal{T} .

for sampled minibatch $\{\mathbf{x}_k\}_{k=1}^N$ **do**

for all $k \in \{1, \dots, N\}$ **do**

draw two augmentation functions $t \sim \mathcal{T}, t' \sim \mathcal{T}$

the first augmentation

$\tilde{\mathbf{x}}_{2k-1} = t(\mathbf{x}_k)$

$\mathbf{h}_{2k-1} = f(\tilde{\mathbf{x}}_{2k-1})$

representation

$\mathbf{z}_{2k-1} = g(\mathbf{h}_{2k-1})$

projection

the second augmentation

$\tilde{\mathbf{x}}_{2k} = t'(\mathbf{x}_k)$

$\mathbf{h}_{2k} = f(\tilde{\mathbf{x}}_{2k})$

representation

$\mathbf{z}_{2k} = g(\mathbf{h}_{2k})$

projection

end for

for all $i \in \{1, \dots, 2N\}$ and $j \in \{1, \dots, 2N\}$ **do**

$s_{i,j} = \mathbf{z}_i^\top \mathbf{z}_j / (\|\mathbf{z}_i\| \|\mathbf{z}_j\|)$ # pairwise similarity

end for

define $\ell(i, j)$ as $\ell(i, j) = -\log \frac{\exp(s_{i,j}/\tau)}{\sum_{k=1}^{2N} \mathbb{1}_{[k \neq i]} \exp(s_{i,k}/\tau)}$

$\mathcal{L} = \frac{1}{2N} \sum_{k=1}^N [\ell(2k-1, 2k) + \ell(2k, 2k-1)]$

update networks f and g to minimize \mathcal{L}

end for

return encoder network $f(\cdot)$, and throw away $g(\cdot)$

Generate a positive pair
by sampling data
augmentation functions

InfoNCE loss:
Use all non-
positive
samples in the
batch as \mathbf{x}^-

SimCLR: Generating positive samples from data augmentation

Algorithm 1 SimCLR's main learning algorithm.

input: batch size N , constant τ , structure of f, g, \mathcal{T} .

for sampled minibatch $\{\mathbf{x}_k\}_{k=1}^N$ **do**

for all $k \in \{1, \dots, N\}$ **do**

 draw two augmentation functions $t \sim \mathcal{T}, t' \sim \mathcal{T}$

 # the first augmentation

$\tilde{\mathbf{x}}_{2k-1} = t(\mathbf{x}_k)$

$\mathbf{h}_{2k-1} = f(\tilde{\mathbf{x}}_{2k-1})$

 # representation

$\mathbf{z}_{2k-1} = g(\mathbf{h}_{2k-1})$

 # projection

 # the second augmentation

$\tilde{\mathbf{x}}_{2k} = t'(\mathbf{x}_k)$

$\mathbf{h}_{2k} = f(\tilde{\mathbf{x}}_{2k})$

 # representation

$\mathbf{z}_{2k} = g(\mathbf{h}_{2k})$

 # projection

end for

for all $i \in \{1, \dots, 2N\}$ and $j \in \{1, \dots, 2N\}$ **do**

$s_{i,j} = \mathbf{z}_i^\top \mathbf{z}_j / (\|\mathbf{z}_i\| \|\mathbf{z}_j\|)$ # pairwise similarity

end for

define $\ell(i, j)$ as $\ell(i, j) = -\log \frac{\exp(s_{i,j}/\tau)}{\sum_{k=1}^{2N} \mathbb{1}_{[k \neq i]} \exp(s_{i,k}/\tau)}$

$\mathcal{L} = \frac{1}{2N} \sum_{k=1}^N [\ell(2k-1, 2k) + \ell(2k, 2k-1)]$

 update networks f and g to minimize \mathcal{L}

end for

return encoder network $f(\cdot)$, and throw away $g(\cdot)$

Generate a positive pair by sampling data augmentation functions

Iterate through and use each of the $2N$ samples as reference, compute average loss

InfoNCE loss: Use all non-positive samples in the batch as \mathbf{x}^-

SimCLR: mini-batch training

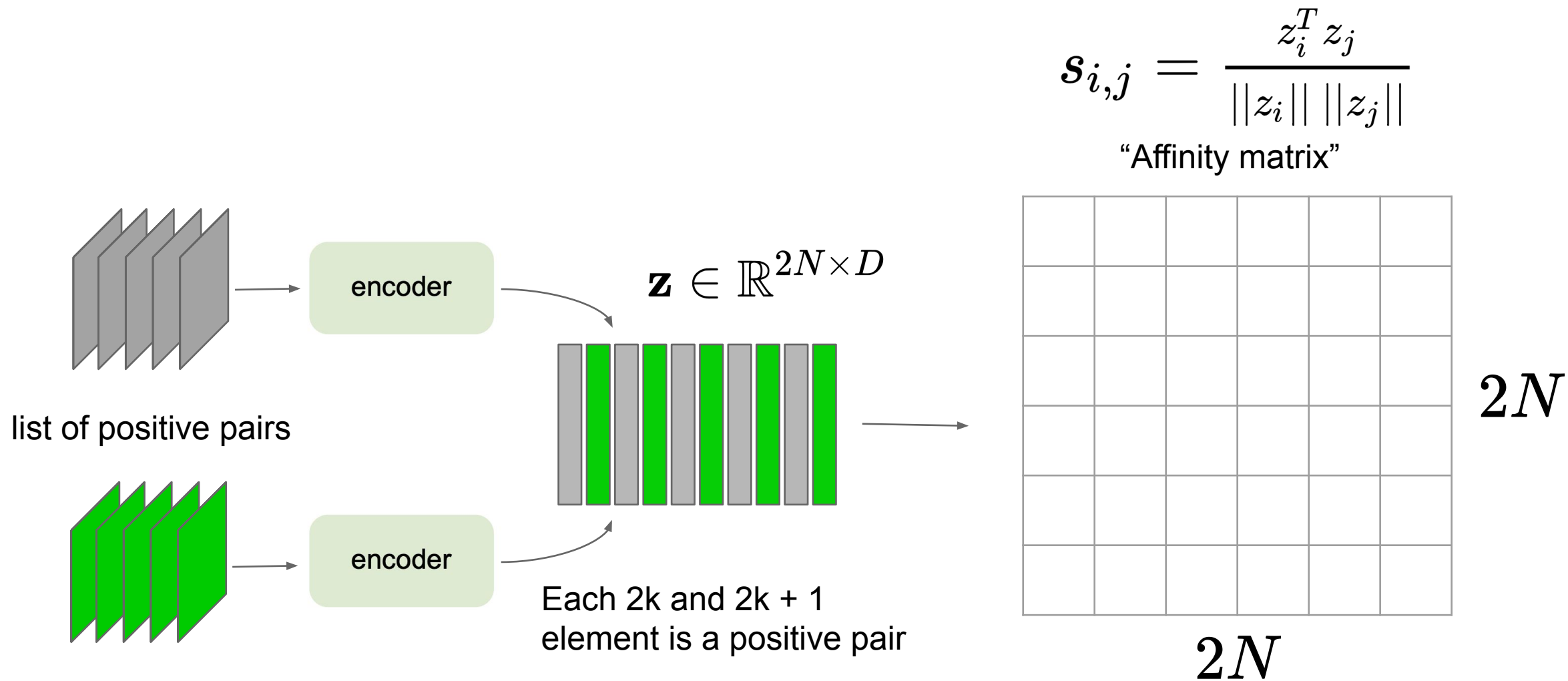

SimCLR: mini-batch training

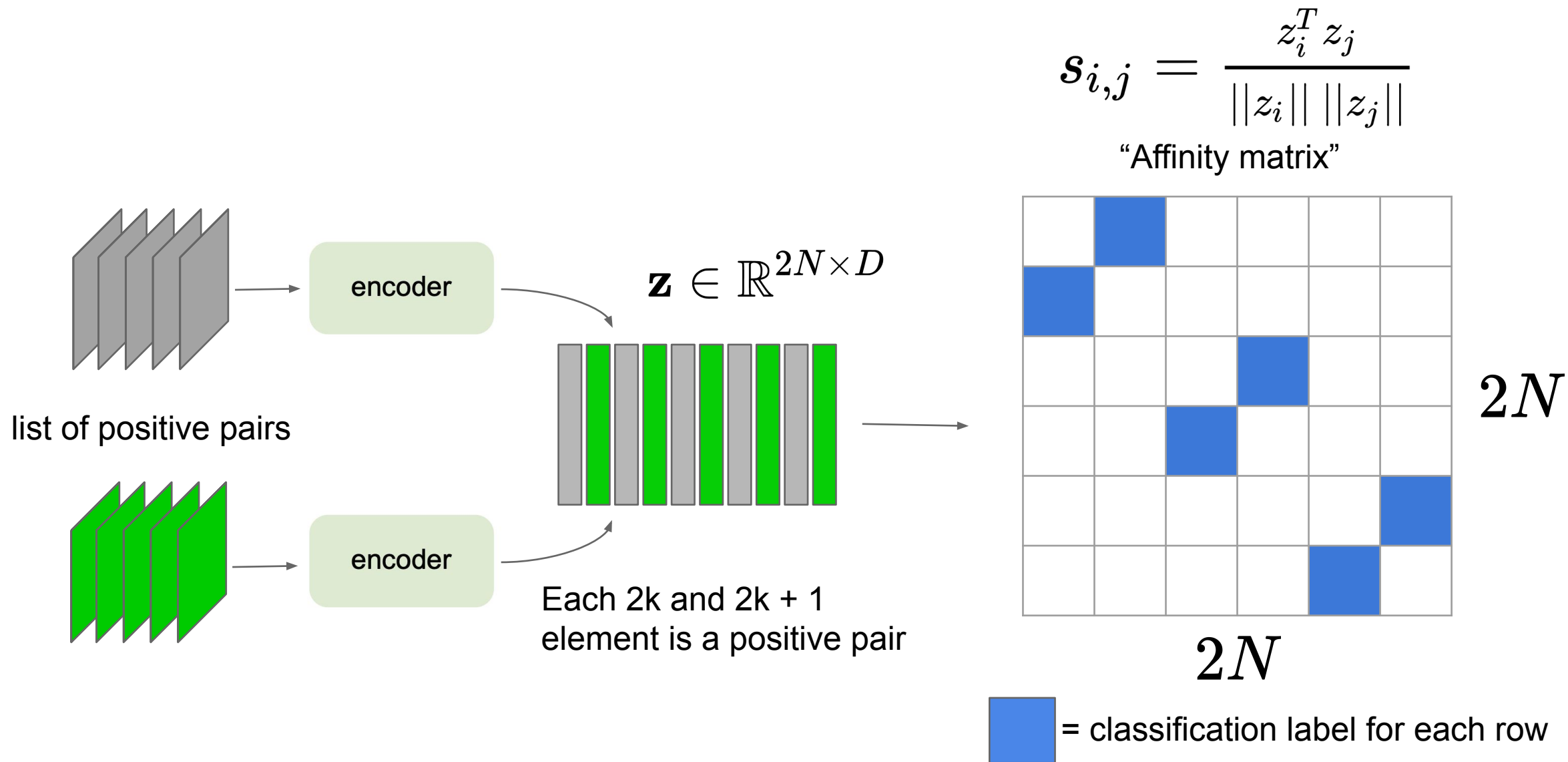

Training linear classifier on SimCLR features

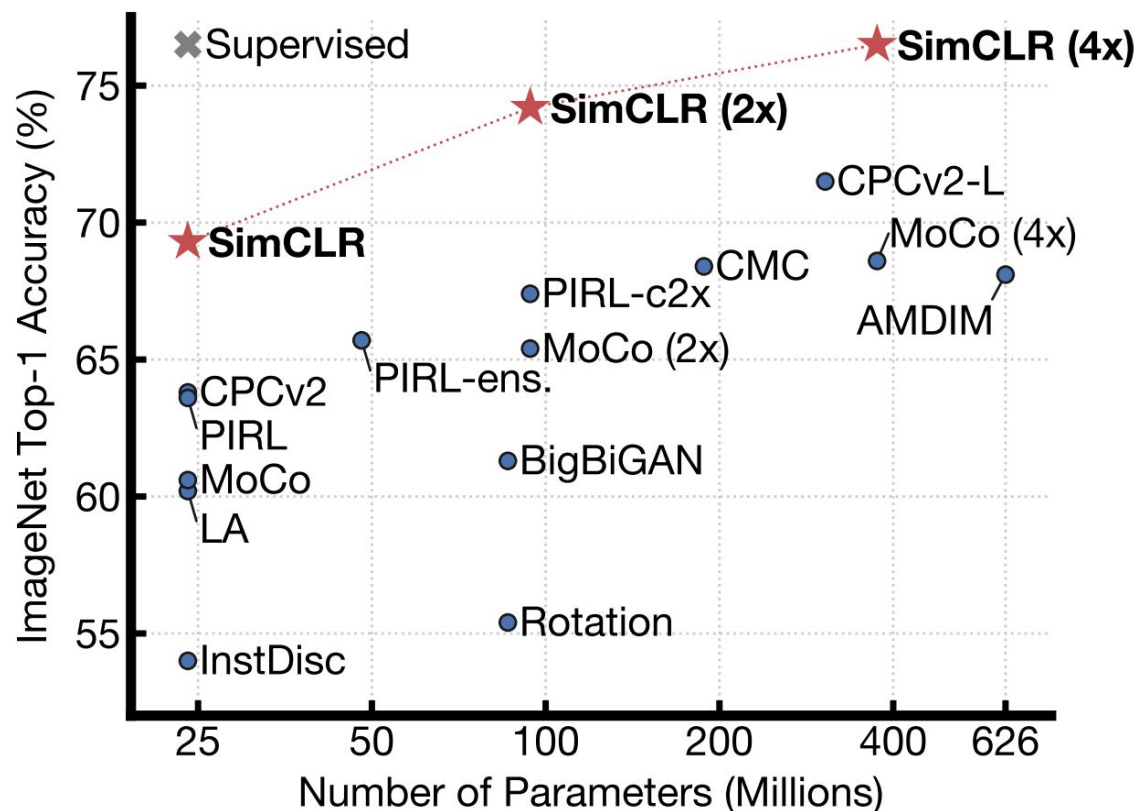

- Train feature encoder on ImageNet (entire training set) using SimCLR.
- Freeze feature encoder, train a linear classifier on top with labeled data.

Training linear classifier on SimCLR features

Method	Architecture	Label fraction	
		1%	10%
Supervised baseline	ResNet-50	48.4	80.4
<i>Methods using other label-propagation:</i>			
Pseudo-label	ResNet-50	51.6	82.4
VAT+Entropy Min.	ResNet-50	47.0	83.4
UDA (w. RandAug)	ResNet-50	-	88.5
FixMatch (w. RandAug)	ResNet-50	-	89.1
S4L (Rot+VAT+En. M.)	ResNet-50 (4×)	-	91.2
<i>Methods using representation learning only:</i>			
InstDisc	ResNet-50	39.2	77.4
BigBiGAN	RevNet-50 (4×)	55.2	78.8
PIRL	ResNet-50	57.2	83.8
CPC v2	ResNet-161(*)	77.9	91.2
SimCLR (ours)	ResNet-50	75.5	87.8
SimCLR (ours)	ResNet-50 (2×)	83.0	91.2
SimCLR (ours)	ResNet-50 (4×)	85.8	92.6

- Train feature encoder on ImageNet (entire training set) using SimCLR.
- **Finetune** the encoder with 1% / 10% of labeled data on ImageNet.

Table 7. ImageNet accuracy of models trained with few labels.

SimCLR design choices: projection head

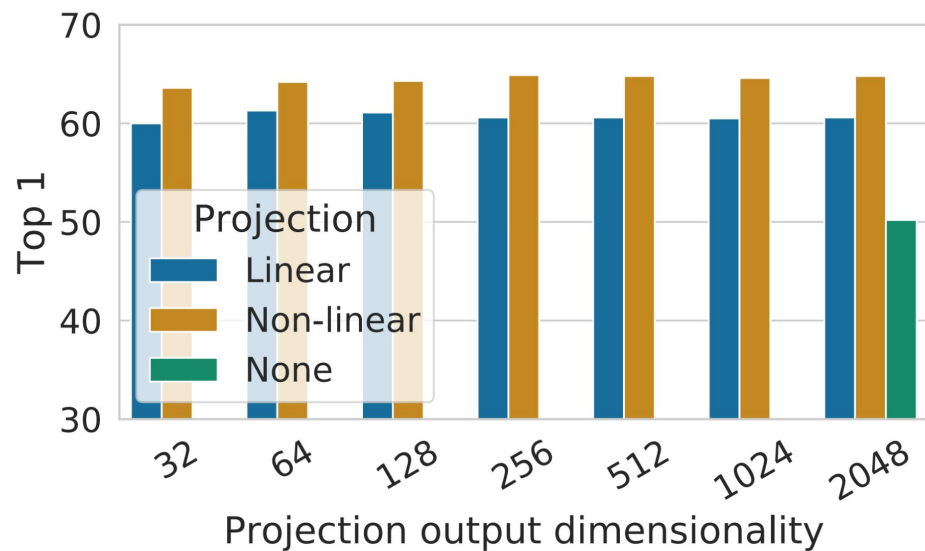

- Linear / non-linear projection heads improve representation learning.
- A possible explanation:
 - contrastive learning objective may discard useful information for downstream tasks
 - representation space \mathbf{z} is trained to be invariant to data transformation.
 - by leveraging the projection head $\mathbf{g}(\cdot)$, more information can be preserved in the \mathbf{h} representation space

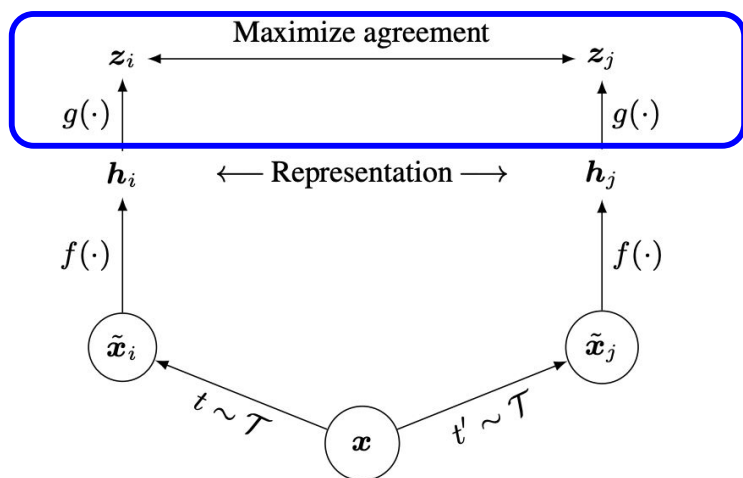

SimCLR design choices: large batch size

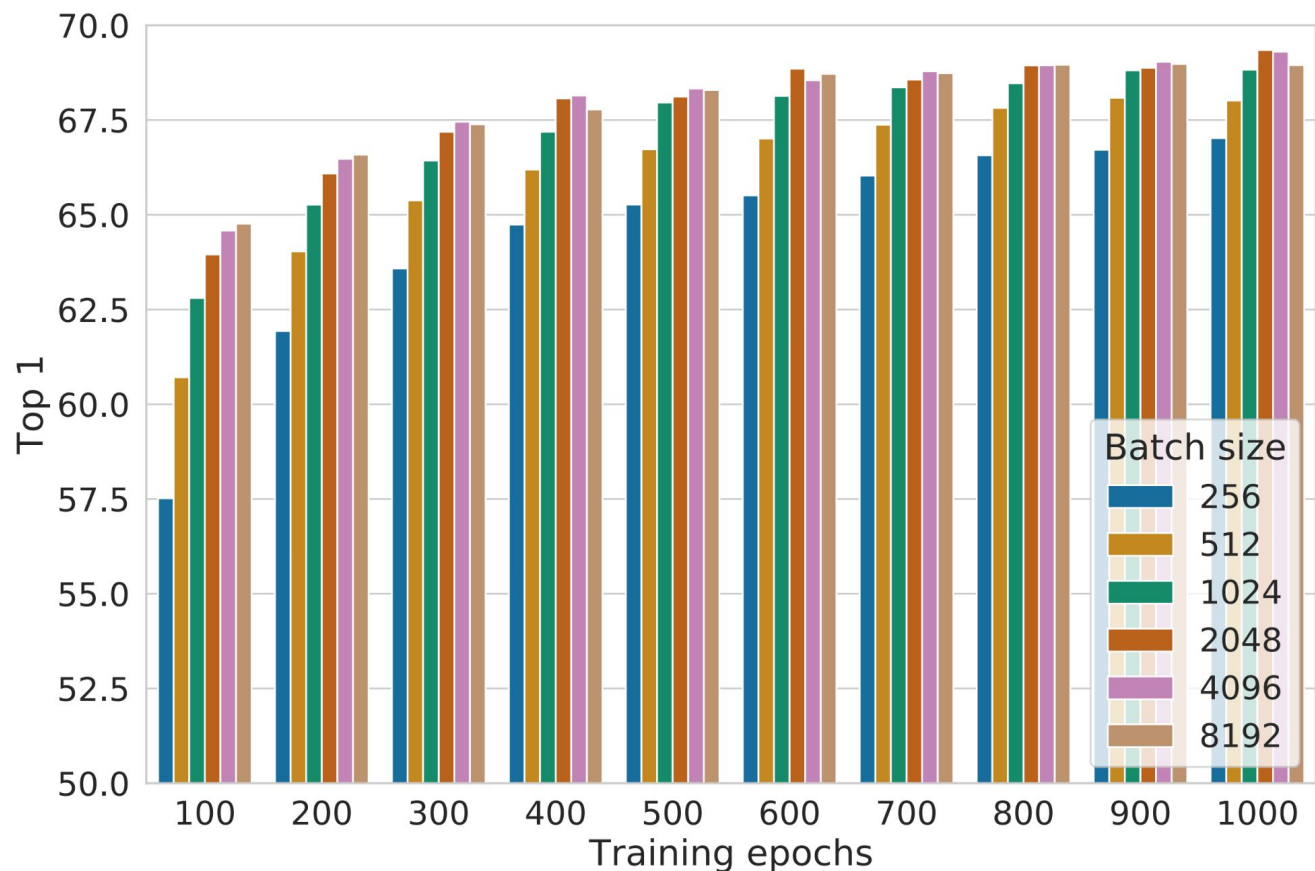

- Large training batch size is crucial for SimCLR!
- Large batch size causes large memory footprint during backpropagation: requires distributed training on TPUs (ImageNet experiments)

Figure 9. Linear evaluation models (ResNet-50) trained with different batch size and epochs. Each bar is a single run from scratch.¹⁰

Momentum Contrastive Learning (MoCo)

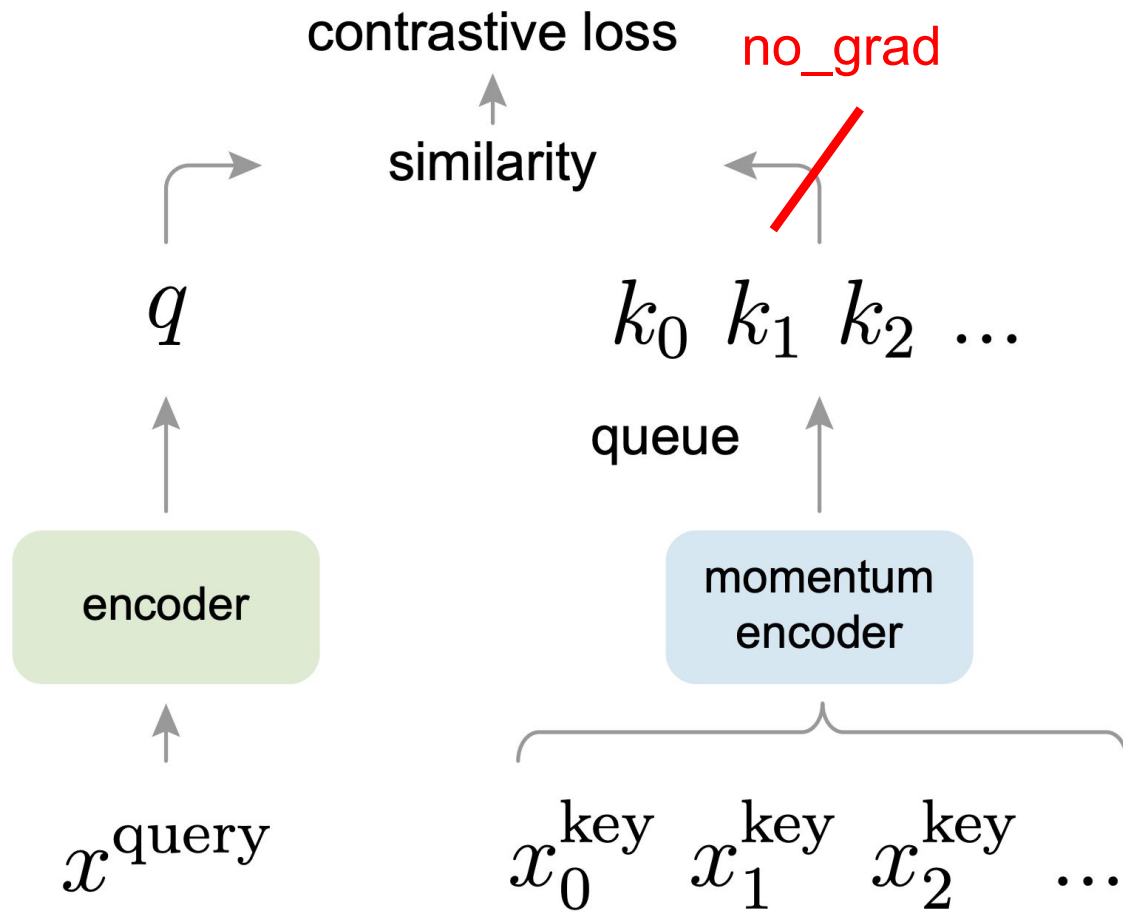

- Key differences to SimCLR:
 - Keep a running **queue** of keys (negative samples).
 - Compute gradients and update the encoder **only through the queries**.
 - Decouple min-batch size with the number of keys: can support **a large number of negative samples**.

Momentum Contrastive Learning (MoCo)

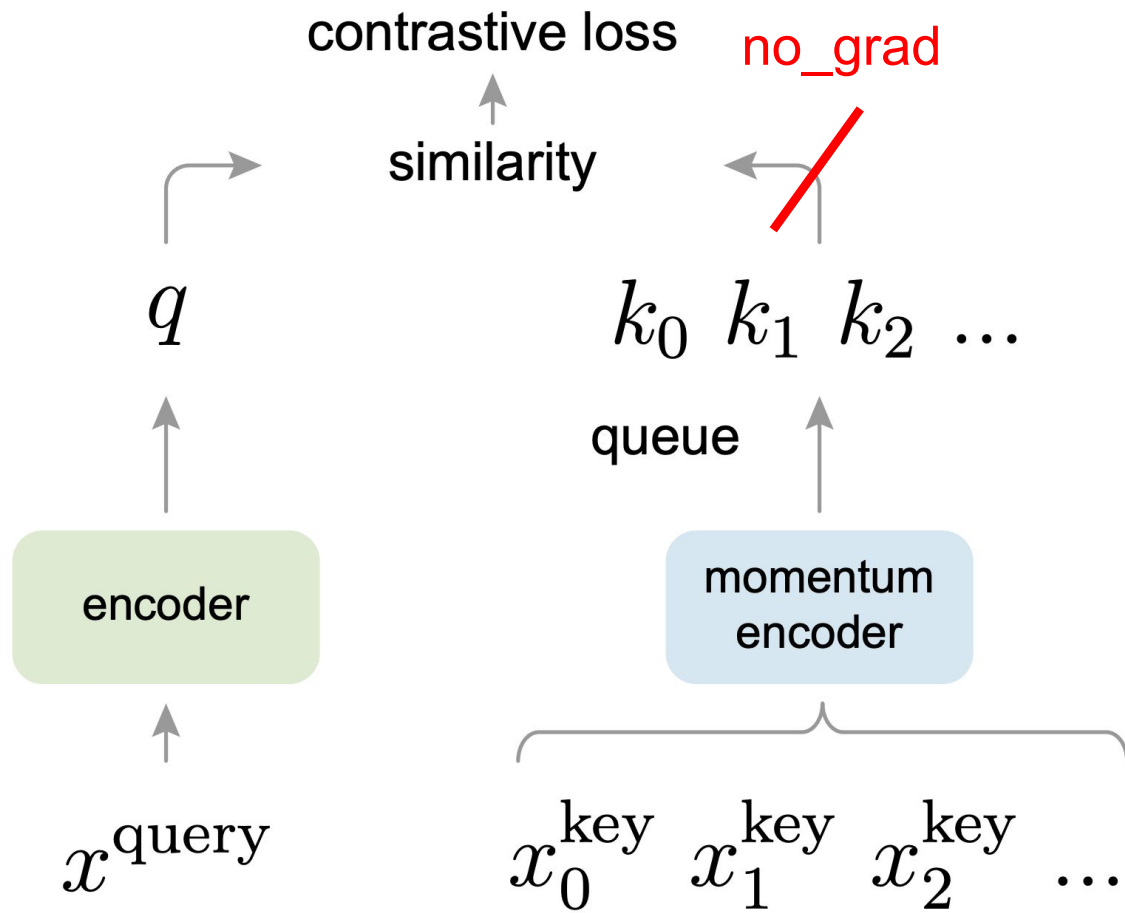

- Key differences to SimCLR:
 - Keep a running **queue** of keys (negative samples).
 - Compute gradients and update the encoder **only through the queries**.
 - Decouple min-batch size with the number of keys: can support **a large number of negative samples**.
 - The key encoder is **slowly progressing** through the momentum update rules:

$$\theta_k \leftarrow m\theta_k + (1 - m)\theta_q$$

MoCo

Algorithm 1 Pseudocode of MoCo in a PyTorch-like style.

```
# f_q, f_k: encoder networks for query and key
# queue: dictionary as a queue of K keys (CxK)
# m: momentum
# t: temperature

f_k.params = f_q.params # initialize
for x in loader: # load a minibatch x with N samples
    x_q = aug(x) # a randomly augmented version
    x_k = aug(x) # another randomly augmented version

    q = f_q.forward(x_q) # queries: Nx C
    k = f_k.forward(x_k) # keys: Nx C
    k = k.detach() # no gradient to keys

    # positive logits: Nx1
    l_pos = bmm(q.view(N, 1, C), k.view(N, C, 1))

    # negative logits: NxK
    l_neg = mm(q.view(N, C), queue.view(C, K))

    # logits: Nx(1+K)
    logits = cat([l_pos, l_neg], dim=1)

    # contrastive loss, Eqn. (1)
    labels = zeros(N) # positives are the 0-th
    loss = CrossEntropyLoss(logits/t, labels)

    # SGD update: query network
    loss.backward()
    update(f_q.params)

    # momentum update: key network
    f_k.params = m*f_k.params+(1-m)*f_q.params

    # update dictionary
    enqueue(queue, k) # enqueue the current minibatch
    dequeue(queue) # dequeue the earliest minibatch
```

Generate a positive pair by sampling data augmentation functions

No gradient through the positive sample

Update the FIFO negative sample queue

Use the running queue of keys as the negative samples

InfoNCE loss

Update f_k through momentum

bmm: batch matrix multiplication; mm: matrix multiplication; cat: concatenation.

MoCo v2

- A hybrid of ideas from SimCLR and MoCo:
- **From SimCLR:** non-linear projection head and strong data augmentation.
- **From MoCo:** momentum-updated queues that allow training on a large number of negative samples (no TPU required!).

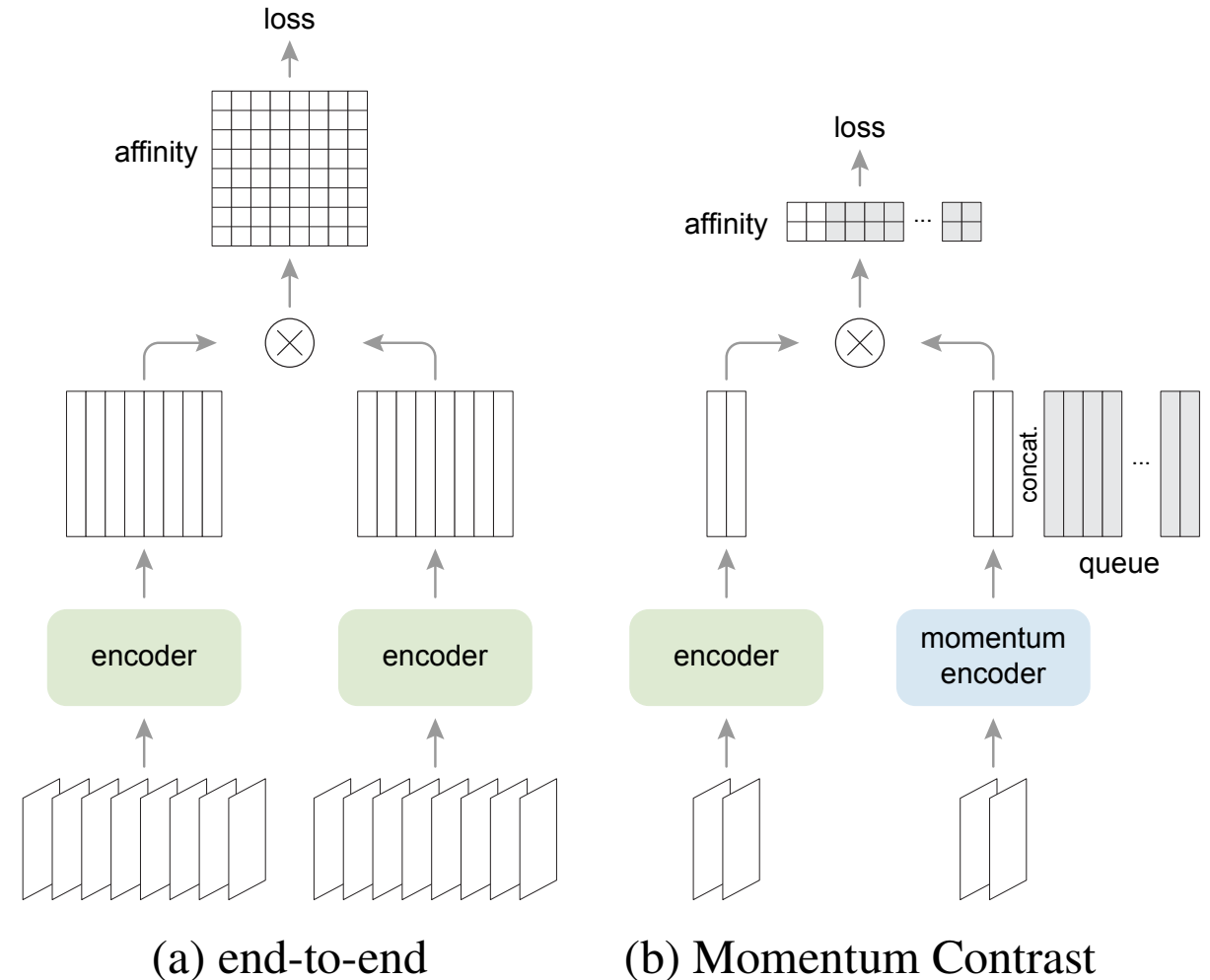

Momentum Contrastive Learning (MoCo)

case	unsup. pre-train				ImageNet acc.	VOC detection		
	MLP	aug+	cos	epochs		AP ₅₀	AP	AP ₇₅
supervised					76.5	81.3	53.5	58.8
MoCo v1				200	60.6	81.5	55.9	62.6
(a)	✓			200	66.2	82.0	56.4	62.6
(b)		✓		200	63.4	82.2	56.8	63.2
(c)	✓	✓		200	67.3	82.5	57.2	63.9
(d)	✓	✓	✓	200	67.5	82.4	57.0	63.6
(e)	✓	✓	✓	800	71.1	82.5	57.4	64.0

Table 1. **Ablation of MoCo baselines**, evaluated by ResNet-50 for (i) ImageNet linear classification, and (ii) fine-tuning VOC object detection (mean of 5 trials). “**MLP**”: with an MLP head; “**aug+**”: with extra blur augmentation; “**cos**”: cosine learning rate schedule.

- **Key takeaways:**

- Non-linear projection head and strong data augmentation are crucial for contrastive learning.

Momentum Contrastive Learning (MoCo)

case	unsup. pre-train					ImageNet acc.
	MLP	aug+	cos	epochs	batch	
MoCo v1 [6]				200	256	60.6
SimCLR [2]	✓	✓	✓	200	256	61.9
SimCLR [2]	✓	✓	✓	200	8192	66.6
MoCo v2	✓	✓	✓	200	256	67.5
<i>results of longer unsupervised training follow:</i>						
SimCLR [2]	✓	✓	✓	1000	4096	69.3
MoCo v2	✓	✓	✓	800	256	71.1

Table 2. **MoCo vs. SimCLR**: ImageNet linear classifier accuracy (**ResNet-50, 1-crop 224×224**), trained on features from unsupervised pre-training. “aug+” in SimCLR includes blur and stronger color distortion. SimCLR ablations are from Fig. 9 in [2] (we thank the authors for providing the numerical results).

- **Key takeaways:**

- Non-linear projection head and strong data augmentation are crucial for contrastive learning.
- Decoupling mini-batch size with negative sample size allows MoCo-v2 to outperform SimCLR with smaller batch size (256 vs. 8192).

Momentum Contrastive Learning (MoCo)

mechanism	batch	memory / GPU	time / 200-ep.
MoCo	256	5.0G	53 hrs
end-to-end	256	7.4G	65 hrs
end-to-end	4096	93.0G [†]	n/a

Table 3. **Memory and time cost** in 8 V100 16G GPUs, implemented in PyTorch. [†]: based on our estimation.

- Key takeaways:
 - Non-linear projection head and strong data augmentation are crucial for contrastive learning.
 - Decoupling mini-batch size with negative sample size allows MoCo-v2 to outperform SimCLR with smaller batch size (256 vs. 8192).
 - ... all with much smaller memory footprint! (“end-to-end” means SimCLR here)

Instance vs. Sequence Contrastive Learning

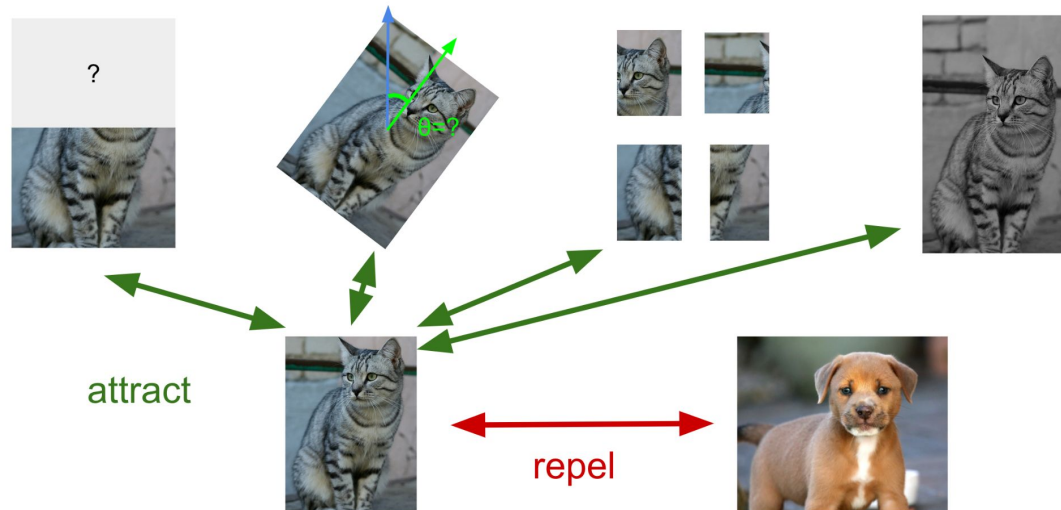

Instance-level contrastive learning:
contrastive learning based on
positive & negative instances.

Examples: SimCLR, MoCo, MoCo v2

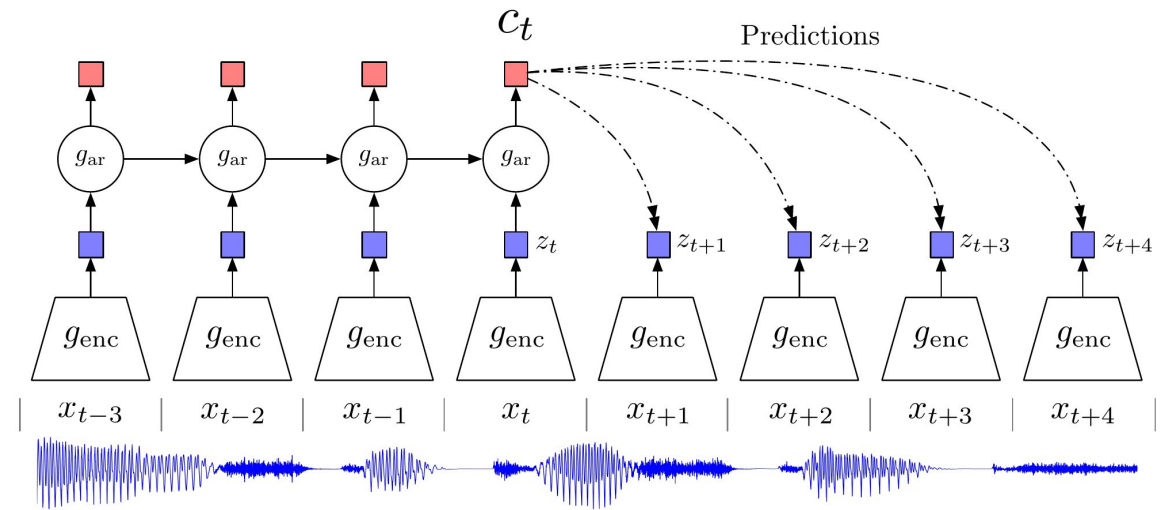

Source: [van den Oord et al., 2018](#)

Sequence-level contrastive learning:
contrastive learning based on
sequential / temporal orders.

Example: Contrastive Predictive Coding (CPC)

Contrastive Predictive Coding (CPC)

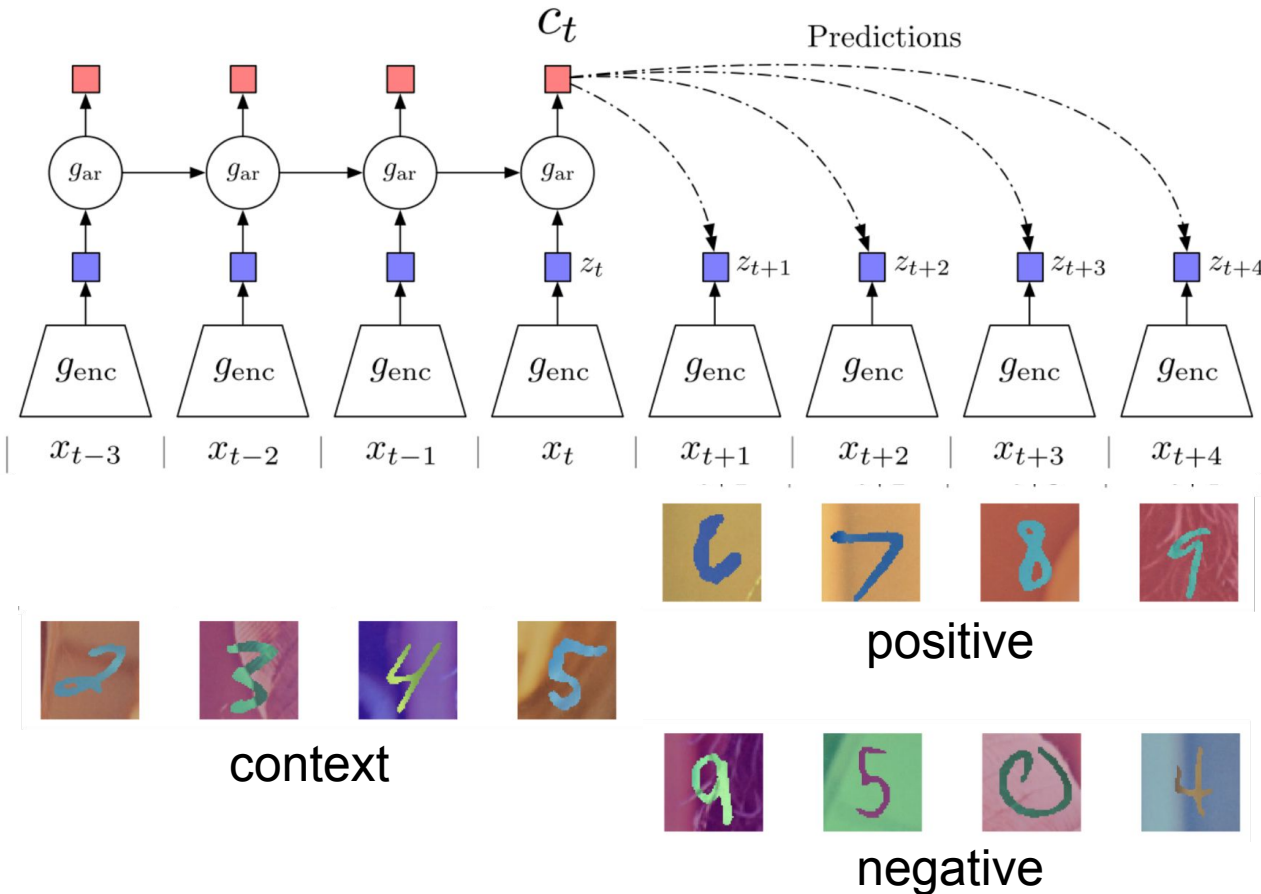

- **Contrastive:** contrast between "right" and "wrong" sequences using contrastive learning.
- **Predictive:** the model has to predict future patterns given the current context.
- **Coding:** the model learns useful feature vectors, or "code", for downstream tasks, similar to other self-supervised methods.

Contrastive Predictive Coding (CPC)

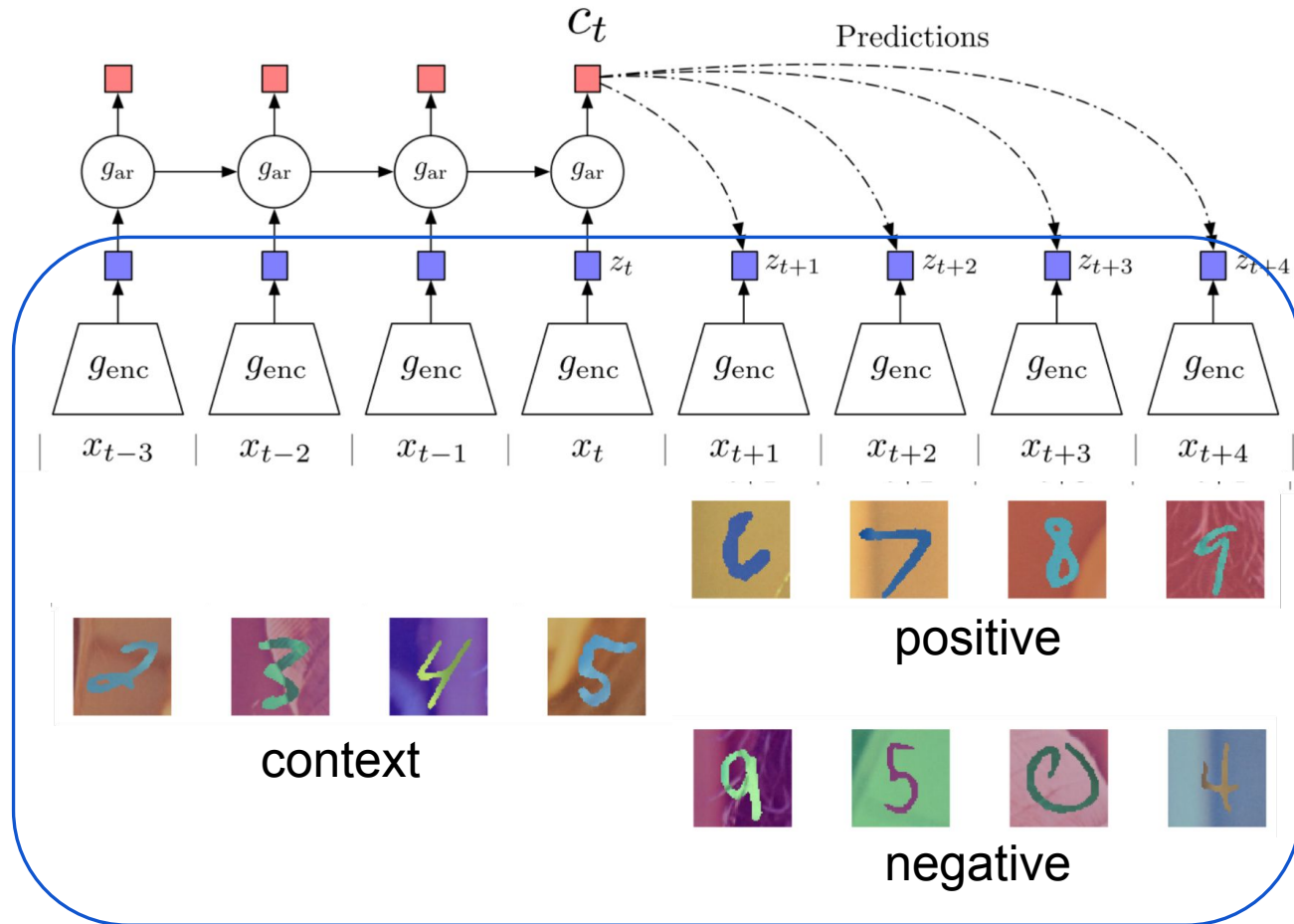

1. Encode all samples in a sequence into vectors $z_t = g_{enc}(x_t)$.

Contrastive Predictive Coding (CPC)

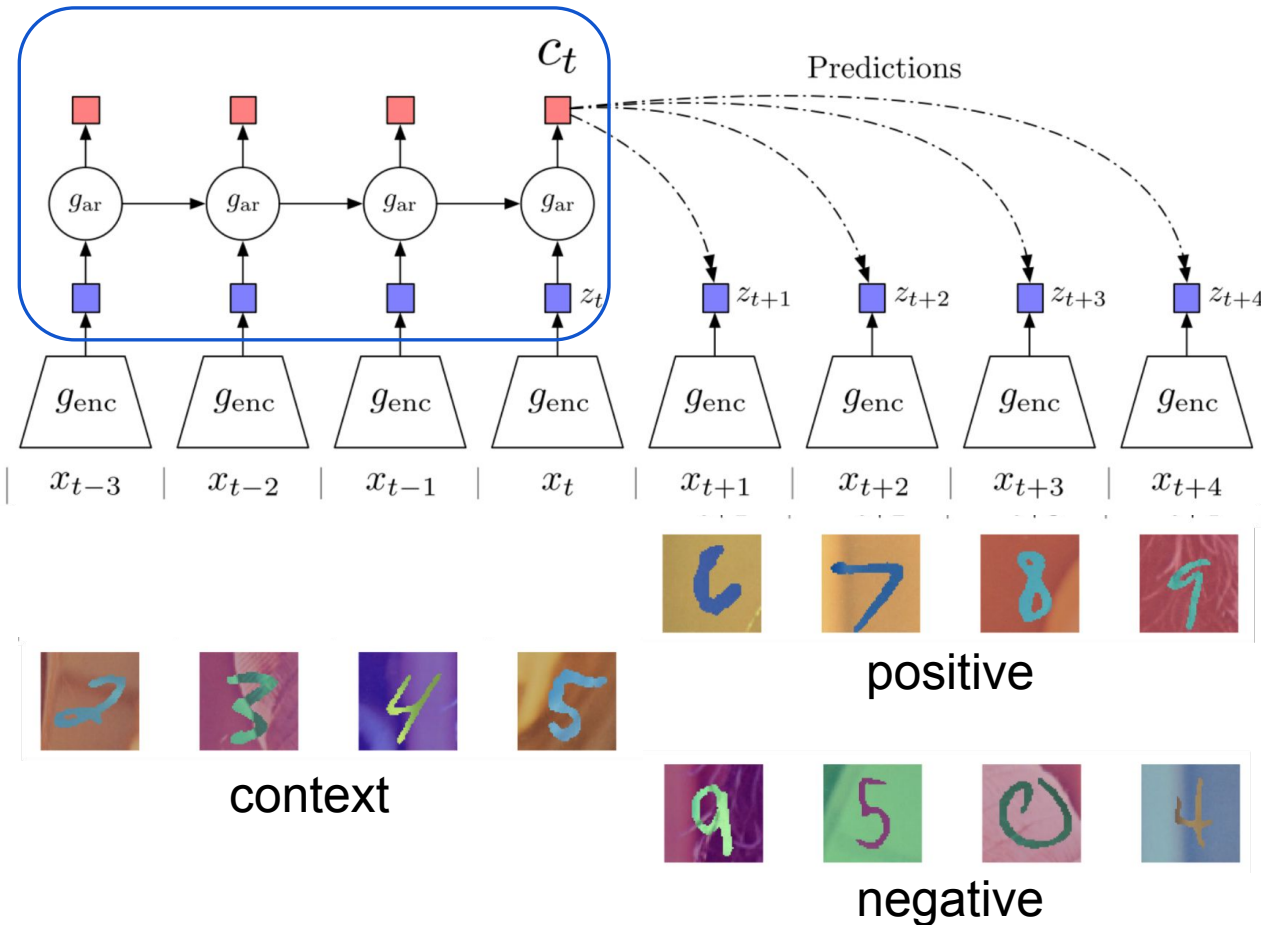

1. Encode all samples in a sequence into vectors $z_t = g_{enc}(x_t)$.
2. Summarize context (e.g., half of a sequence) into a context code c_t using an auto-regressive model (g_{ar}). The original paper uses GRU-RNN here.

CPC example: modeling audio sequences

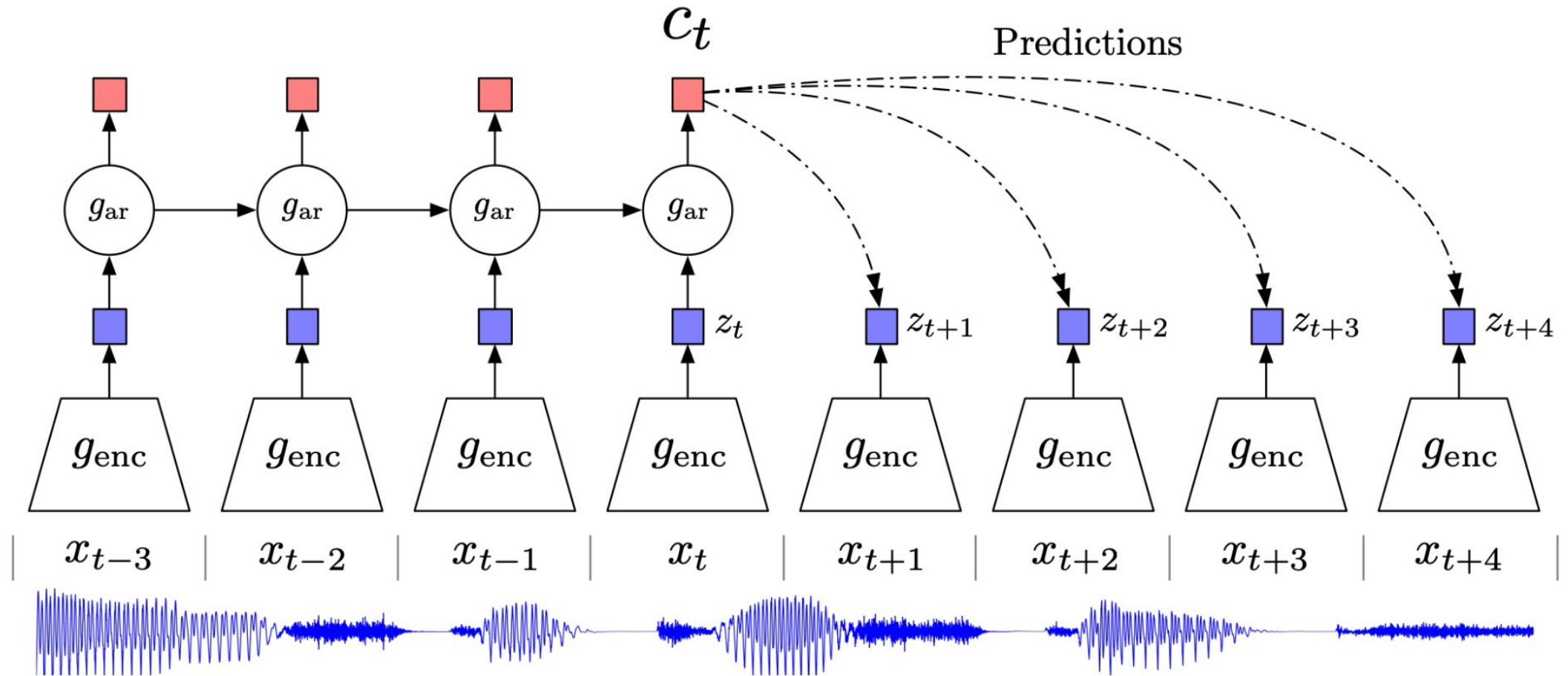

CPC example: modeling audio sequences

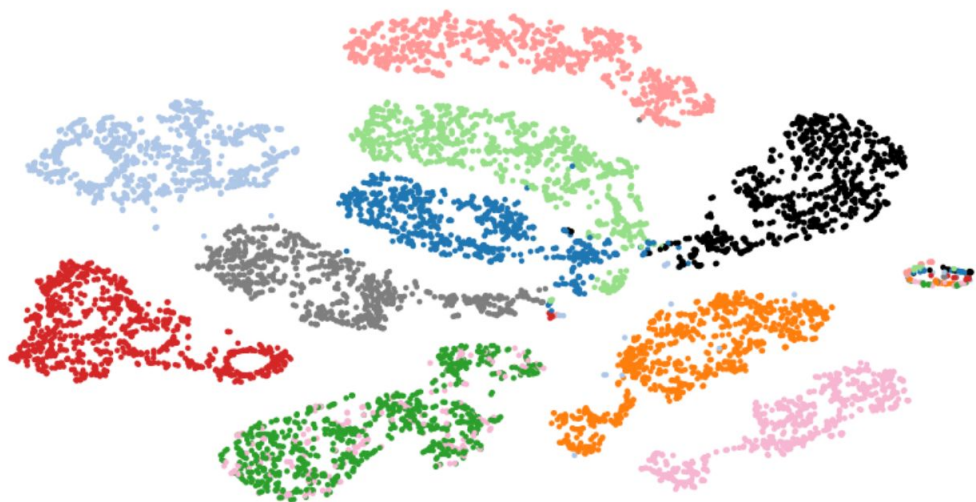

Figure 2: t-SNE visualization of audio (speech) representations for a subset of 10 speakers (out of 251). Every color represents a different speaker.

Method	ACC
Phone classification	
Random initialization	27.6
MFCC features	39.7
CPC	64.6
Supervised	74.6
Speaker classification	
Random initialization	1.87
MFCC features	17.6
CPC	97.4
Supervised	98.5

Linear classification on trained representations (LibriSpeech dataset)

CPC example: modeling audio sequences

- Idea: split image into patches, model rows of patches from top to bottom as a sequence. I.e., use top rows as context to predict bottom rows.

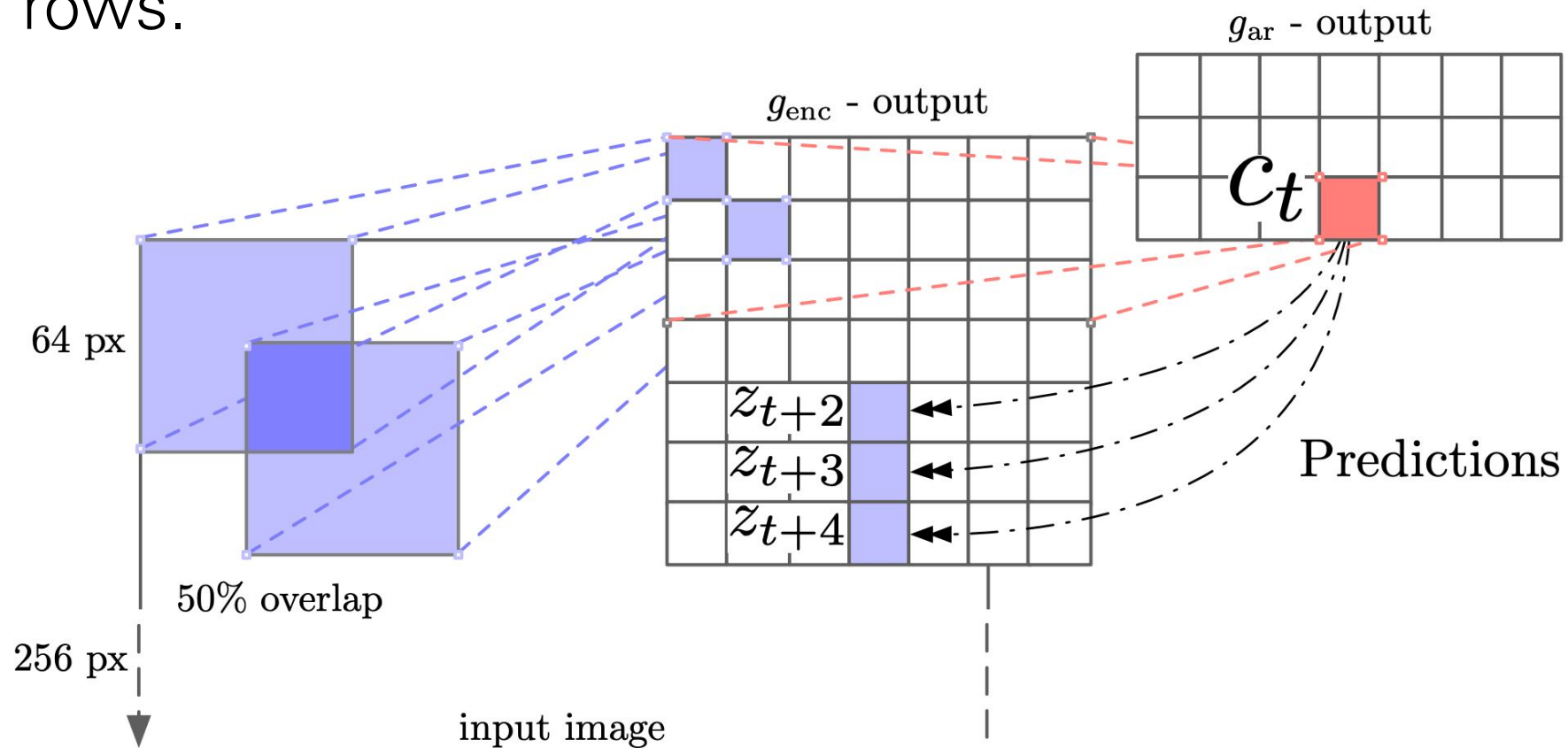

CPC example: modeling audio sequences

Method	Top-1 ACC
Using AlexNet conv5	
Video [28]	29.8
Relative Position [11]	30.4
BiGan [35]	34.8
Colorization [10]	35.2
Jigsaw [29] *	38.1
Using ResNet-V2	
Motion Segmentation [36]	27.6
Exemplar [36]	31.5
Relative Position [36]	36.2
Colorization [36]	39.6
CPC	48.7

Table 3: ImageNet top-1 unsupervised classification results. *Jigsaw is not directly comparable to the other AlexNet results because of architectural differences.

- Compares favorably with other pretext task-based self-supervised learning method.
- Doesn't do as well compared to newer instance-based contrastive learning methods on image feature learning.

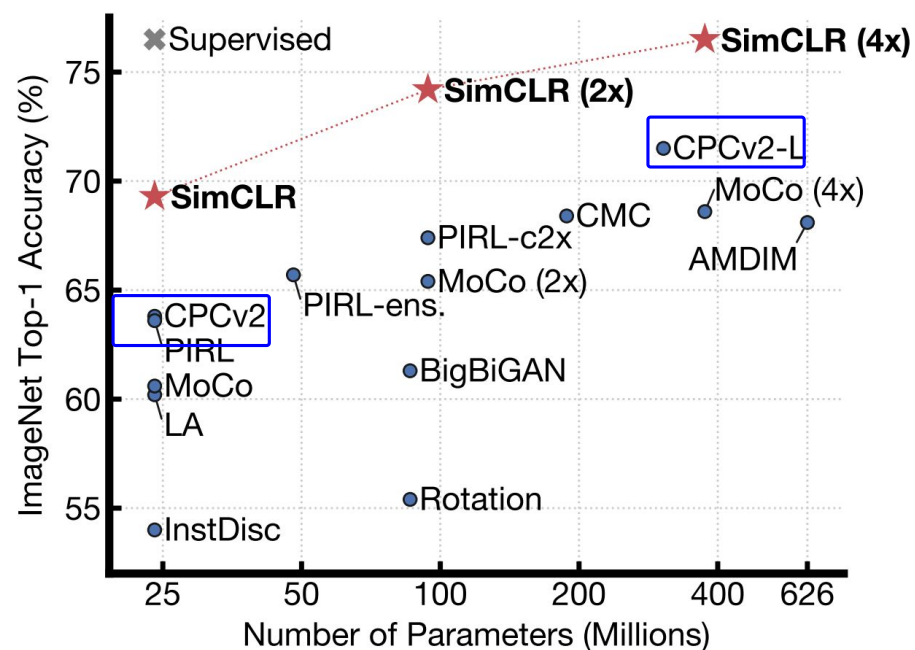

Masked Autoencoders (MAE)

A ~~new~~ old method dethrones contrastive learning? Denoising Autoencoder with Vision Transformer

Masked Autoencoders (MAE)

A new old method dethrones contrastive learning? Denoising Autoencoder with Vision Transformer

Divide image into
nonoverlapping patches,
discard most of them

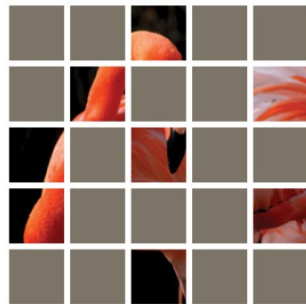

input

Masked Autoencoders (MAE)

A new old method dethrones contrastive learning? Denoising Autoencoder with Vision Transformer

Divide image into nonoverlapping patches, discard most of them

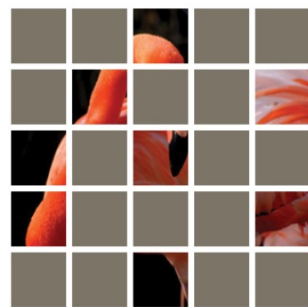

input

Encode remaining patches with a ViT

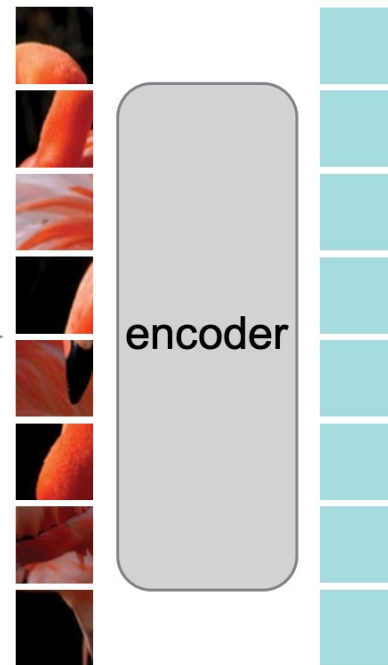

Masked Autoencoders (MAE)

A new old method dethrones contrastive learning? Denoising Autoencoder with Vision Transformer

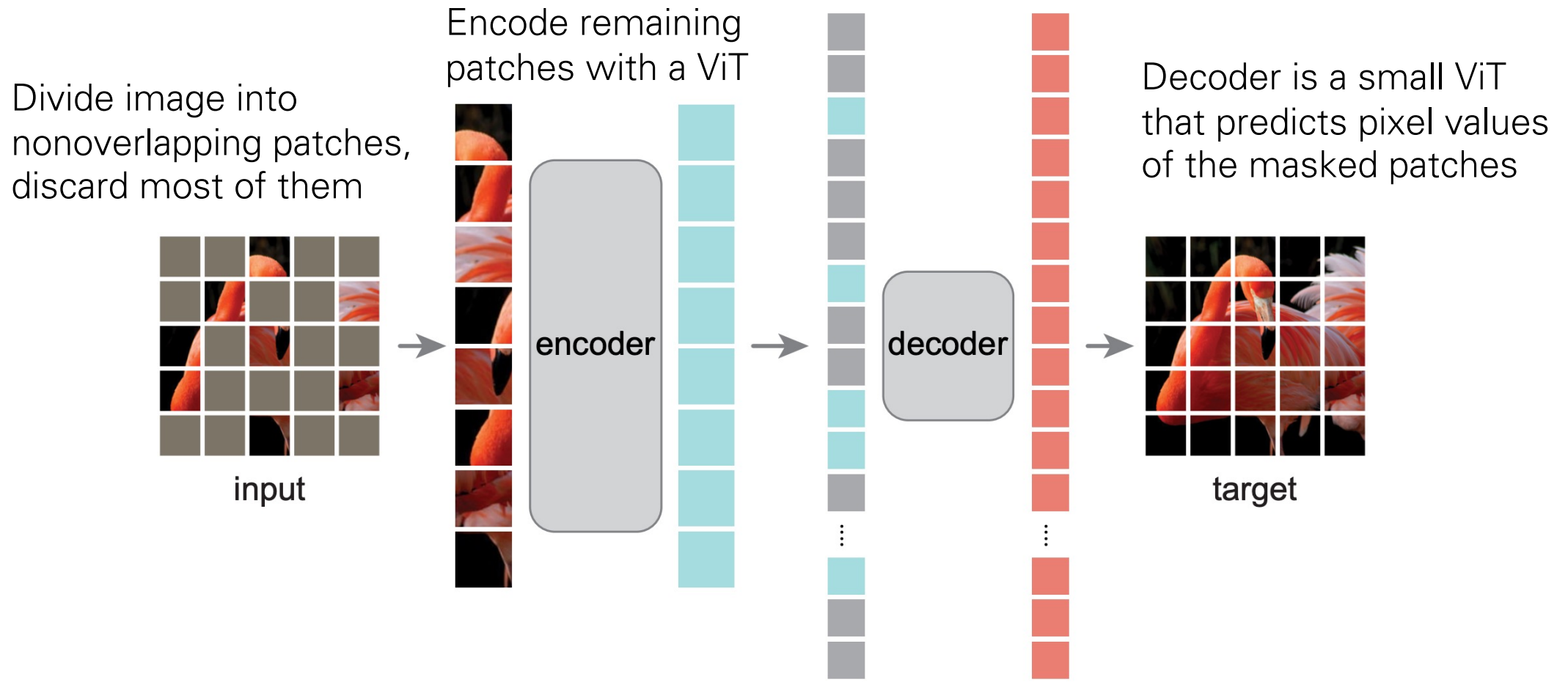

Masked Autoencoders (MAE)

Input Patches

Prediction

Actual Image

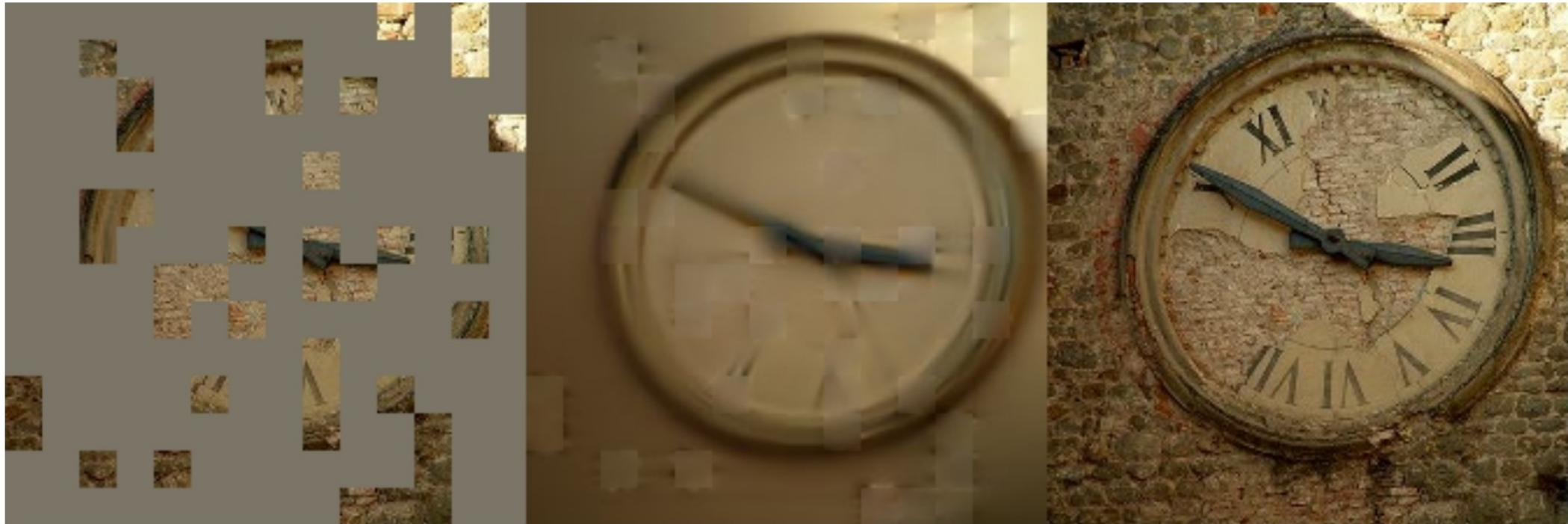

Masked Autoencoders (MAE)

Input Patches



Prediction

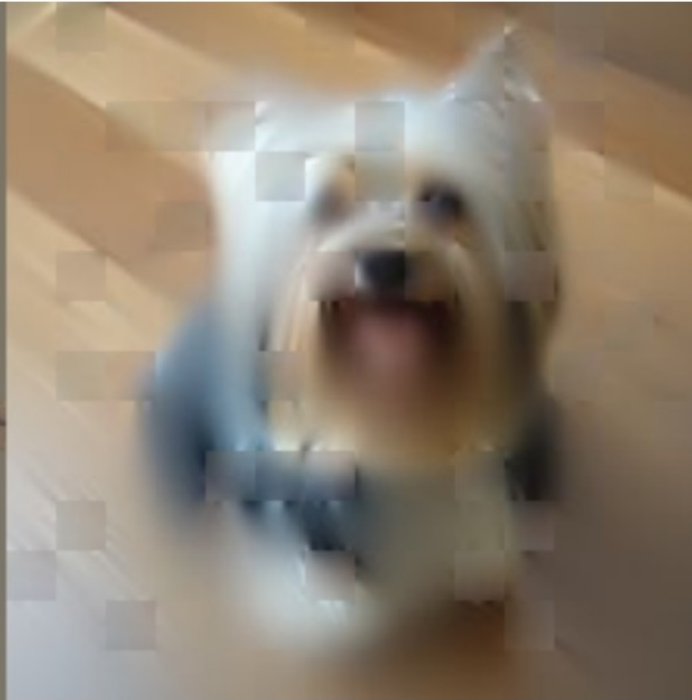

Actual Image



Masked Autoencoders (MAE)

Input Patches



Prediction



Actual Image



Masked Autoencoders (MAE)

SSL Pretraining, then finetuning for ImageNet Classification

■ ViT-B ■ ViT-L ■ ViT-H ■ ViT-H-448

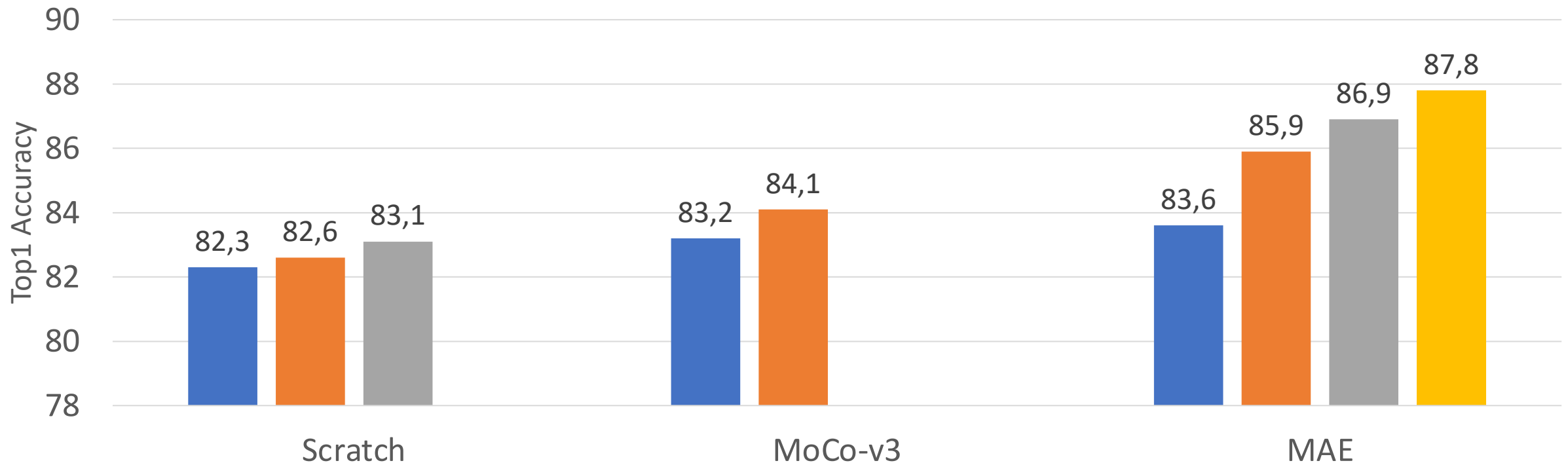

MAE Pretraining outperforms training from scratch, and allows scaling to larger ViT models

Multimodal Self-Supervised Learning

Multimodal Self-Supervised Learning

Don't learn from isolated images -- take images together with some **context**

Video: Image together with adjacent video frames

Agrawal et al, "Learning to See by Moving", ICCV 2015

Wang et al, "Unsupervised Learning of Visual Representations using Videos", ICCV 2015

Pathak et al, "Learning Features by Watching Objects Move", CVPR 2017

Multimodal Self-Supervised Learning

Don't learn from isolated images -- take images together with some **context**

Video: Image together with adjacent video frames

Agrawal et al, "Learning to See by Moving", ICCV 2015

Wang et al, "Unsupervised Learning of Visual Representations using Videos", ICCV 2015

Pathak et al, "Learning Features by Watching Objects Move", CVPR 2017

Sound: Image with audio track from video

Owens et al, "Ambient Sound Provides Supervision for Visual Learning", ECCV 2016

Arandjelovic and Zisserman, "Look, Listen and Learn", ICCV 2017

Multimodal Self-Supervised Learning

Don't learn from isolated images -- take images together with some **context**

Video: Image together with adjacent video frames

Agrawal et al, "Learning to See by Moving", ICCV 2015

Wang et al, "Unsupervised Learning of Visual Representations using Videos", ICCV 2015

Pathak et al, "Learning Features by Watching Objects Move", CVPR 2017

Sound: Image with audio track from video

Owens et al, "Ambient Sound Provides Supervision for Visual Learning", ECCV 2016

Arandjelovic and Zisserman, "Look, Listen and Learn", ICCV 2017

3D: Image with depth map or point cloud

Xie et al, "PointContrast: Unsupervised Pre-training for 3D Point Cloud Understanding", ECCV 2020

Zhang et al, "Self-supervised pretraining of 3D features on any point-cloud", CVPR 2021

Multimodal Self-Supervised Learning

Don't learn from isolated images -- take images together with some **context**

Video: Image together with adjacent video frames

Agrawal et al, "Learning to See by Moving", ICCV 2015

Wang et al, "Unsupervised Learning of Visual Representations using Videos", ICCV 2015

Pathak et al, "Learning Features by Watching Objects Move", CVPR 2017

Sound: Image with audio track from video

Owens et al, "Ambient Sound Provides Supervision for Visual Learning", ECCV 2016

Arandjelovic and Zisserman, "Look, Listen and Learn", ICCV 2017

3D: Image with depth map or point cloud

Xie et al, "PointContrast: Unsupervised Pre-training for 3D Point Cloud Understanding", ECCV 2020

Zhang et al, "Self-supervised pretraining of 3D features on any point-cloud", CVPR 2021

Language: Image with natural-language text

Sariyildiz et al, "Learning Visual Representations with Caption Annotations", ECCV 2020

Desai and Johnson, "VirTex: Learning Visual Representations from Textual Annotations", CVPR 2021

Radford et al, "Learning Transferable Visual Models from Natural Language Supervision", ICML 2021

Jia et al, "Scaling up Visual and Vision-Language Representation Learning with Noisy Text Supervision", ICLR 2021

Desai et al, "RedCaps: Web-curated Image-Text data created by the people, for the people", NeurIPS 2021

Matching Images and Text

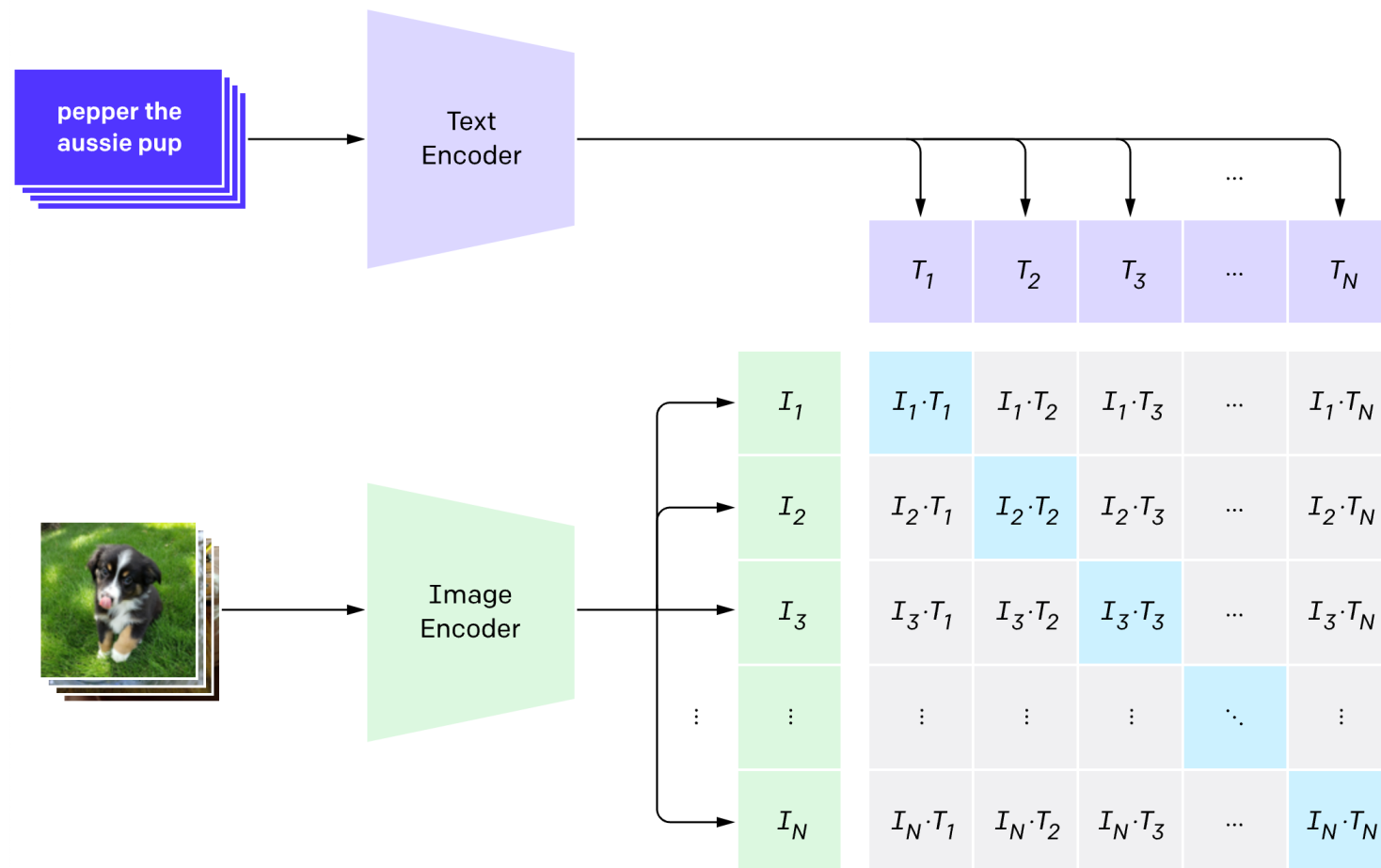

Contrastive loss: Each image predicts which caption matches

Matching Images and Text: CLIP

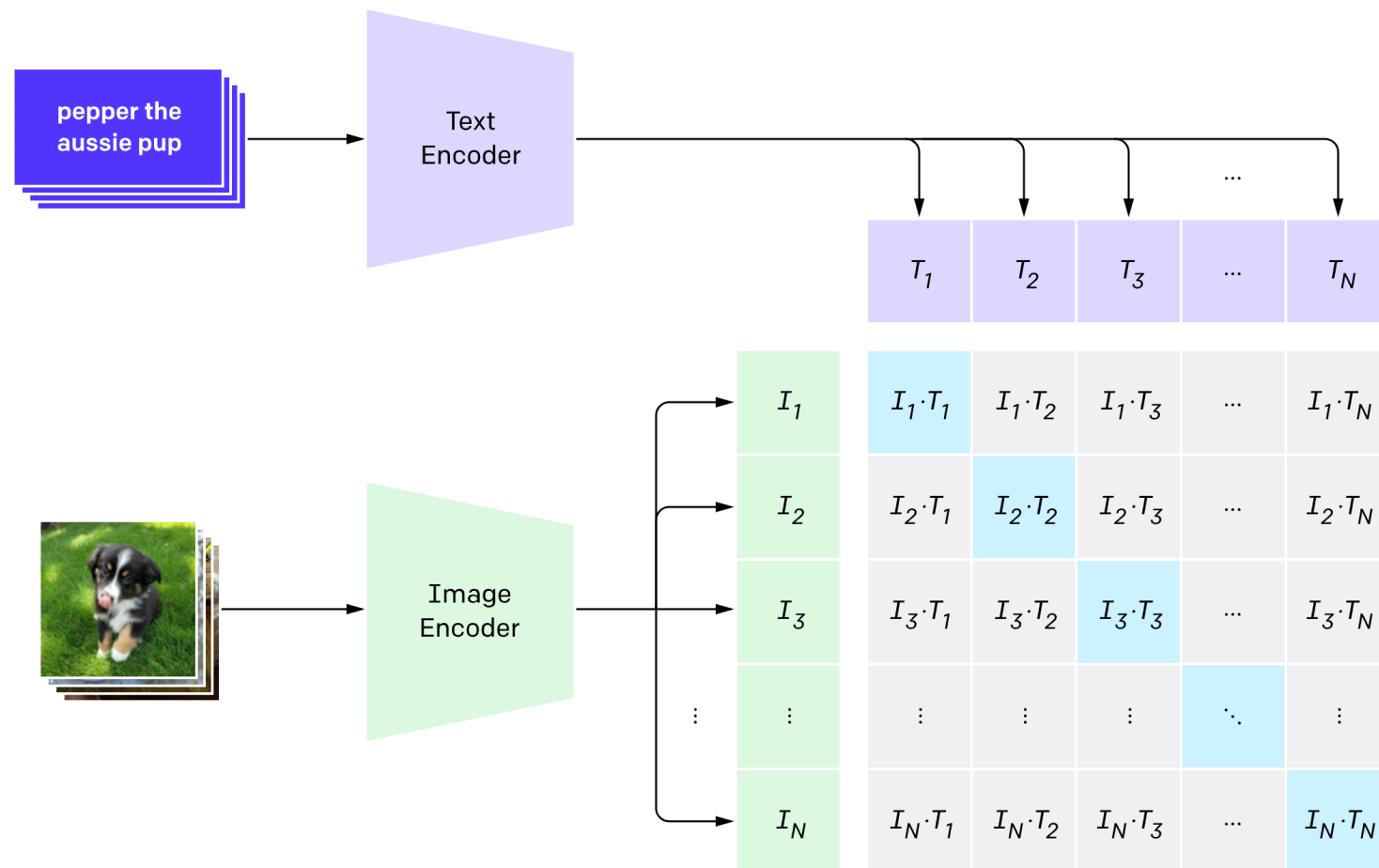

Contrastive loss: Each image predicts which caption matches

Large-scale training on 400M (image, text) pairs from the internet

Matching Images and Text: CLIP

Very strong performance on many downstream vision problems!

Performance continues to improve with larger models

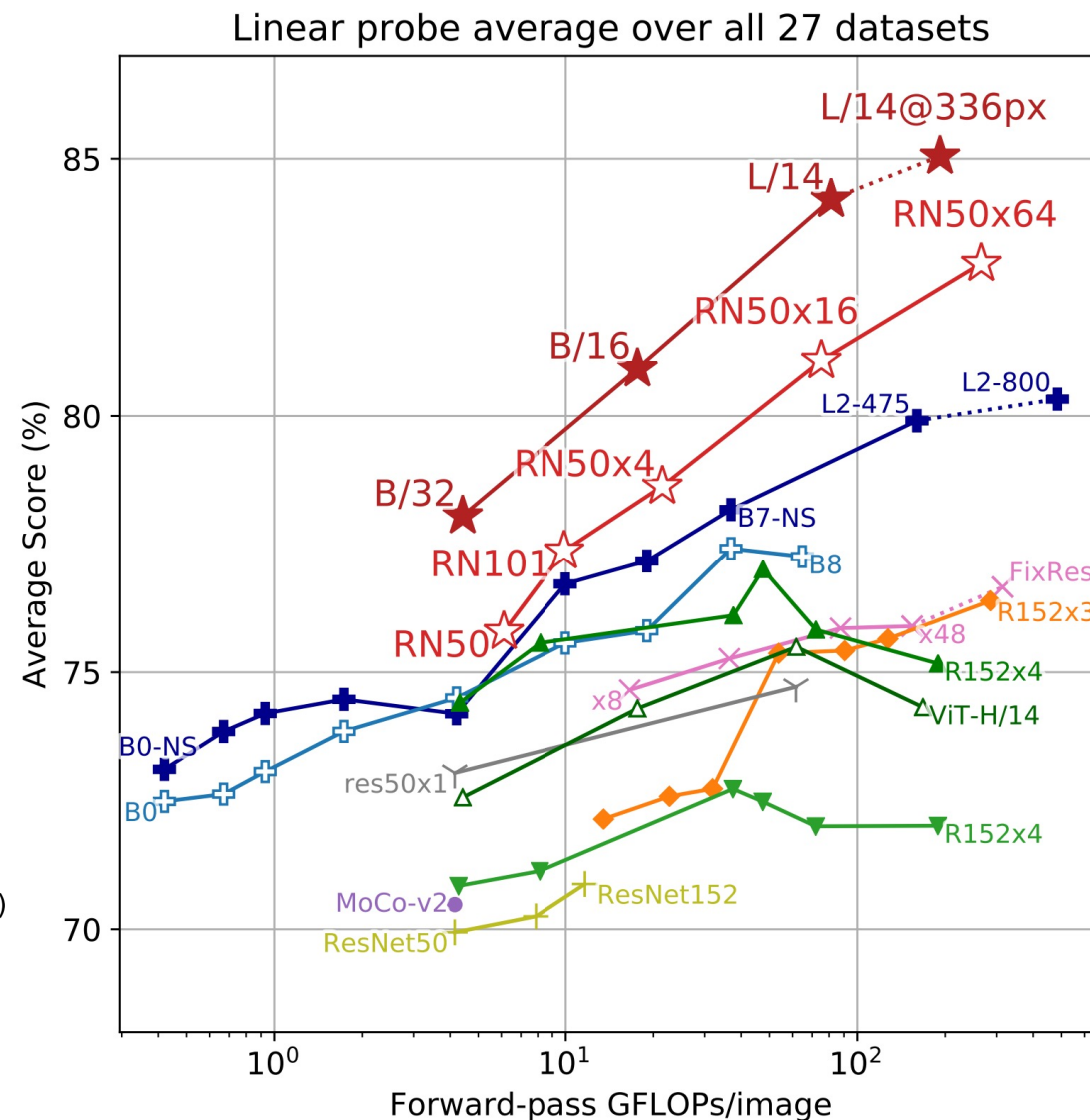
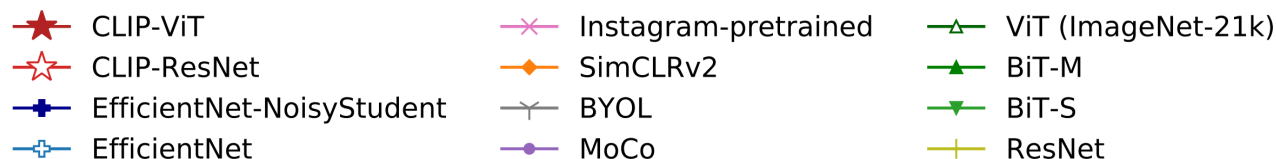

CLIP: Zero-Shot Classification

(2) Create dataset classifier from label text

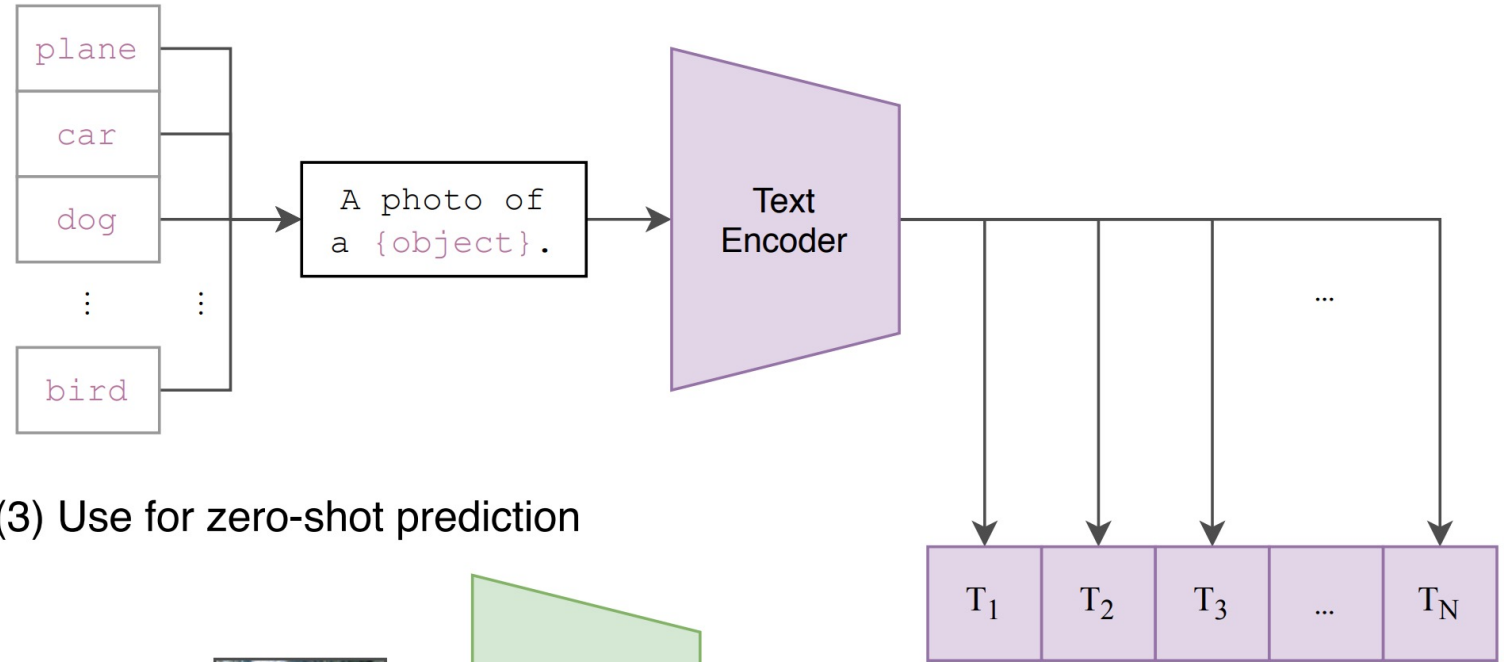

(3) Use for zero-shot prediction

Language enables
zero-shot classification:
Classify images into
categories without any
additional training data!

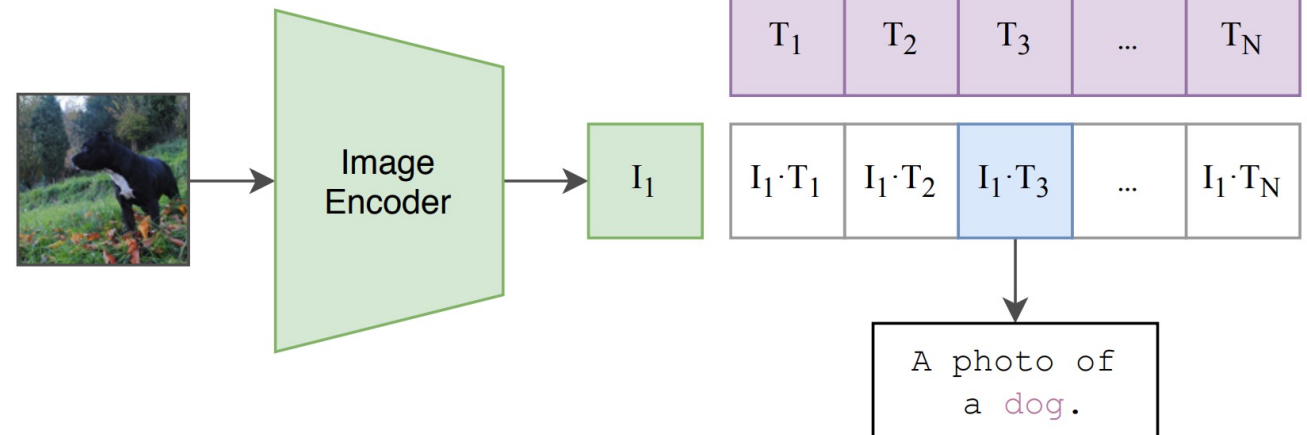

CLIP: Zero-Shot Classification

(2) Create dataset classifier from label text

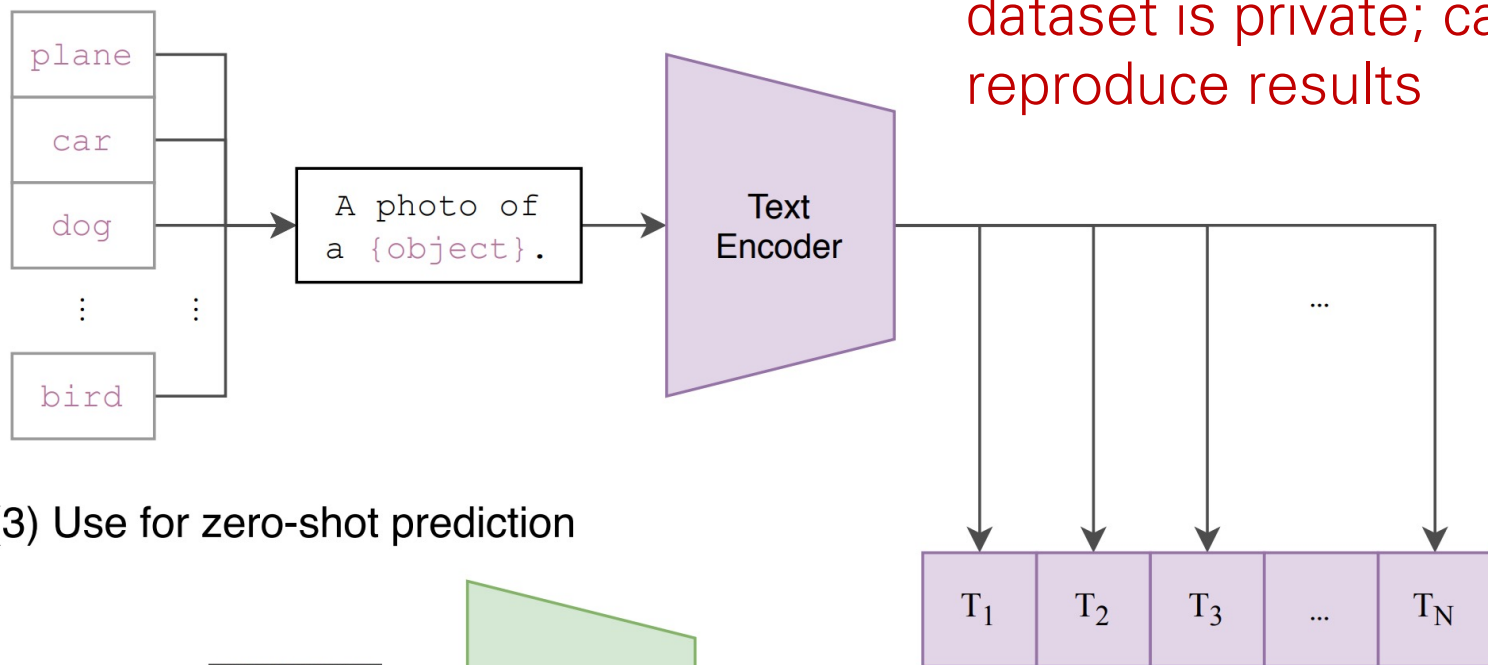

Problem: CLIP training dataset is private; can't reproduce results

(3) Use for zero-shot prediction

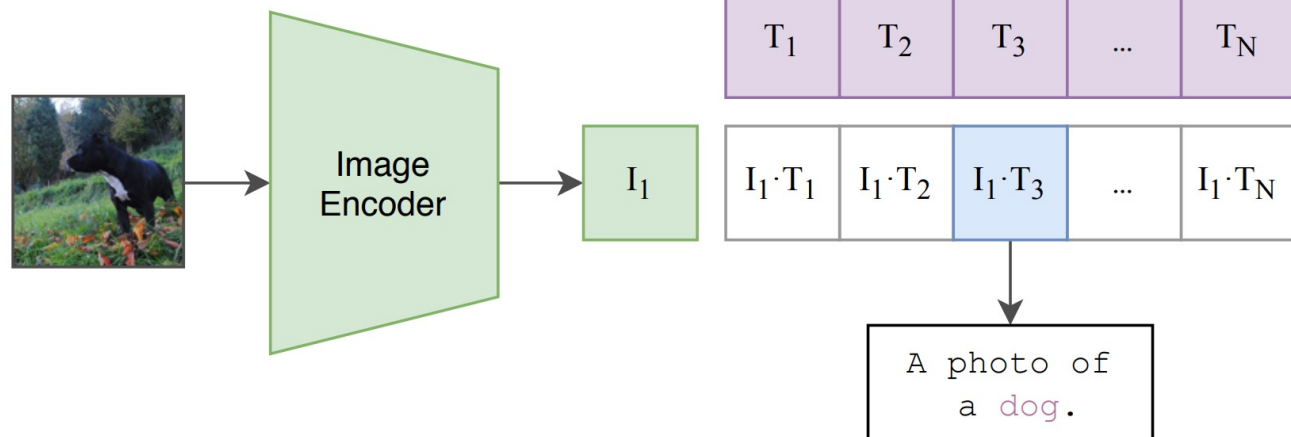

Language enables zero-shot classification: Classify images into categories without any additional training data!

Summary

- Self-Supervised Learning (SSL) aims to scale up to larger datasets without human annotation
- First train for a **pretext** task, then **transfer** to **downstream** tasks
- Many pretext tasks: context prediction, jigsaw, colorization, clustering, rotation
- SSL has been wildly successful for language
- Intense research on SSL in vision; current best are contrastive, masked autoencoding
- Multimodal SSL uses images together with additional context
- Multimodal SSL with vision + language has been very successful; seems very promising!